

SKID LOADER SPECIALS



Gehl 4835SXT, 57 HP Diesel, 68" Bucket, 1998 #05515
\$9,700



Gehl 4625, 44 HP, 65" Bucket, 1996, 2290 Hours, T Bar Control #05732
\$10,800

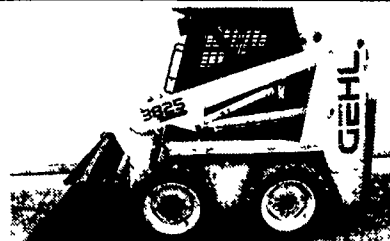

Gehl 3825, 34 HP, 1995, 54" Bucket #05883
\$8,600

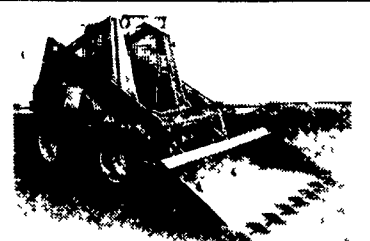

NH L785, 57 HP Diesel, With Bucket, 1994, 2 Speed, 4026 Hours #05145
\$11,500

QUALITY USED EQUIPMENT



Gehl 8335 Mixer Feeder, 335 cu ft, Flip-up Discharge #05313 **\$13,900**

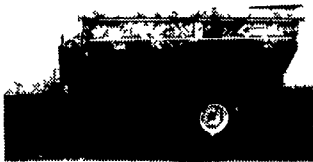

Gehl 7190 Feeder Wagon #05854 **\$2,500**

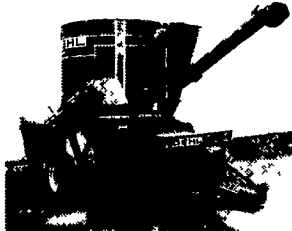

Gehl 125 Grinder Mixer, 100 Bushel #04726 **\$5,600**



Luck-Now 285 Mixer Feeder, 285 cu.ft. with Scale #04075 **\$9,650**

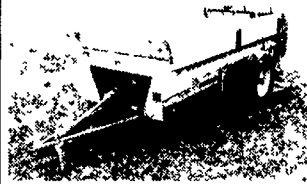

New Idea 3622 Spreader, 225 Bushel, Top Beater, Litter Pan, 12" Wood Sides #900149 **\$6,500**



NH 492 Mower Conditioner, 9 Ft Cut, Field Ready, New Rolls #05874 **\$3,900**

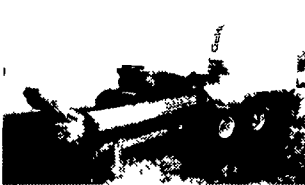

Gehl 1075 Harvester, With 1000 Crop Processor & 3-Row Corn Head #05914 **\$19,900**



Kuhn Disc Conditioner 13'2" Cut, Standard Hitch #05152 **\$12,500**



Husky Manure Pump, 32 Ft, 1000 PTO, 2 Point Hitch #04885 **\$3,900**

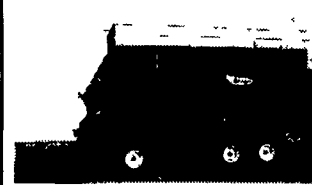

Badger Forage Box, 12-Ton Gear, 16 Ft, 3 Beaters, Roof #04947 **\$3,500**



Gehl 2360 Disc Conditioner, 10'3" Cut #05690 **\$8,900**

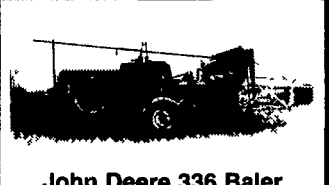

John Deere 336 Baler #05713 **\$2,800**



MF 3090-2 95 HP Diesel, 12x4 Trans, 2329 Hours, 1986 #05671 **\$21,000**



MF 383 73 HP, 2099 Hours, 1997, w/MF 236 Loader w/78" Bucket #05772 **\$15,900**



MF281X 69 HP, 8x6 Trans, Dual Aux Hyd, 180 Hours, 2000, Excellent Condition #05878 **\$16,900**



Ford 5610S 66 HP, 1990, 8x2 Trans, 1721 Hours, Single Aux Hyd, #05926 **\$13,800**



Oliver 1650 66 HP Diesel, 6x2 Trans w/Over & Under, Good Working Condition #05948 **\$5,900**



MF 253 48 HP, 8x2 Trans, 1996, 1575 Hours, Dual Ax Hyd #05868 **\$13,900**



MF 8140-4C 145 HP, DynaShuttle Trans, 1998, 977 Hours #05793 **\$48,900**



MF 3140-2 115 HP, 4 Speed Trans, 1993, 4694 Hours #05790 **\$24,900**



MF 4270-4 99 HP, 1998, 12x12 Shuttle Trans, 883 Hours, w/MF 1048 Loader #05782 **\$31,900**



MF 399-4 99 HP Diesel, 12x4 Trans, 1670 Hours, 1986, #05626 **\$18,900**

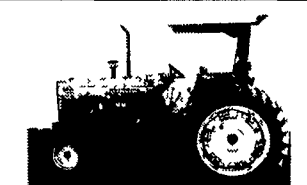

MF 399-2 99 HP Diesel, 12x4 Trans, 4400 Hours, 1987, #05865 **\$13,900**



MF 399-2 95 HP, 12x4 Trans, 1990, 2927 Hours, Nice #05958 **\$16,900**

PENTA VERTICAL TMR



Vertical Mixers



Models 2400, 3000, 4100, 5600, 6700, 8000 & 11000 Available

Call us for Demo and Pricing.

Features

- 5 year pro-rated warranty on gear box
- 3 year warranty on Digistar Scales
- Stainless steel conveyor trough
- Extra heavy duty frame
- 46" wide door
- 4 - 16 ply tires
- Epoxy paint
- Excellent Clean Out
- Made from North American Steel
- Easy loading with skid loader



GEHL One Tough Box Spreader

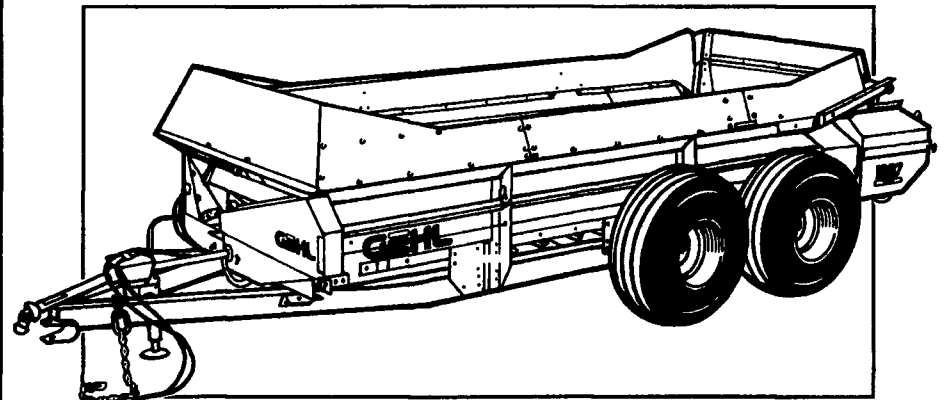

Models In Stock: • 1217 • 1287 • 1410

Gehl Box Spreaders deliver outstanding performance in a variety of materials. And they're built extra-strong for more years of dependable service. Available in four sizes, these units can be custom-equipped to match your operation.

Lebanon Valley Implement Co., Inc.

700 E. Linden Street, Richland, PA 17087 **717-866-7518**



LEBANON VALLEY IMPLEMENT COMPANY, INC.

700 EAST LINDEN STREET, RICHLAND, PA 17087

Monday - Friday 7:30-5
Saturday 7:30-12

717-866-7518

EMAIL: sales@lebanonvalleyimplement.com
See our Equipment at: www.ironweb.com/lebanonvalley

