

VISIT OUR EXHIBIT AT AG PROGRESS DAYS - EAST 3RD STREET

J-STAR

STOP AT OUR EXHIBIT AND CHECK OUT THE "ROLL BACK" PRICING!

America's Best!

**MAGNUM II™
SURFACE DRIVE SILO UNLOADER**

America's best selling silo unloader just got better! Van Dale's been writing the book on silo unloading technology for more than 45 years. And Van Dale invented and perfected the surface drive unloader. Now it's time to introduce the next generation. The MAGNUM II!

The new MAGNUM II features a brand new Hi Perform™ Impeller which adds more "throw power" than ever before. Check it out and then check in with your Van Dale Dealer.

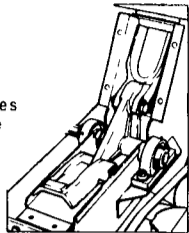

CHECK OUT THESE FEATURES

- ✓ Full 1/4" stainless steel back wrapper
- ✓ Formed 10-gauge stainless steel discharge area
- ✓ Adjustable 1/4" abrasion resistant cut-off plate
- ✓ Easy-access inspection cover
- ✓ 27" impeller

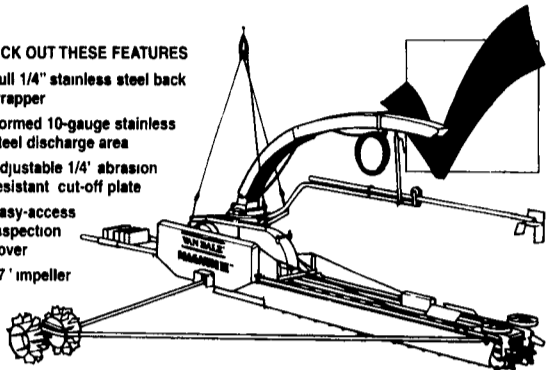

THE VAN DALE ADVANTAGE

Contact your local dealer for details!

VAN DALE Dependability through Quality

Silo Unloader Technology Takes a Giant Leap Forward!

BIG JIM. Quantum SYSTEM

TOWER SILOS REALLY MEASURE UP!

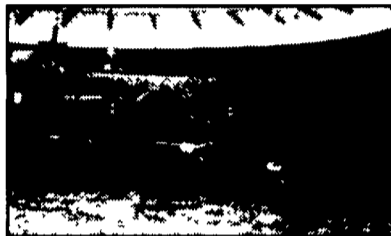

Measure for measure, nothing beats a tower silo for storing forage. Just compare them to bunkers which have up to 45% storage loss, lower capacity, increased labor and lots of inconvenience.

Towers lose just 3% to 7% because of gravity, feed weight and a good unloader like the Big Jim QUANTUM System. QUANTUM can be installed in any type of 20' to 30' forage silo - conventional or oxygen limited and will make your tower silo even better!

CALL US TODAY FOR A VIDEO AND BROCHURE

The Silo Unloader Experts



LEASE IT TODAY WITH ONE PAYMENT DOWN!

VOLUMAXX

GIVES YOU A CHOICE OF DISTRIBUTION

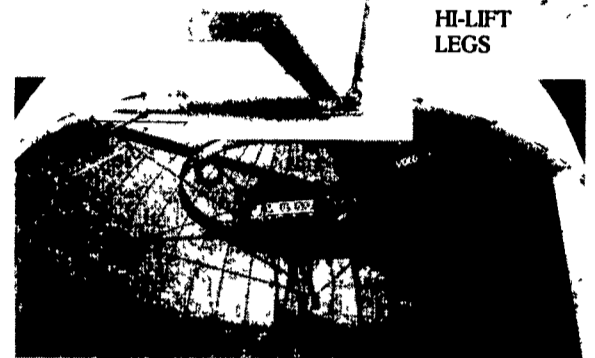

HI-LIFT LEGS

The new advance design Volumaxx unloader gives you the best of both worlds... your choice of distribution. New HI-LIFT legs let you raise the unloader an extra 15" into the silo roof, so you can use a conventional side

distributor. Or, choose the Jamesway Powermaxx™ broad pan silage distributor. With proper distribution, you'll have better quality feed, and you'll increase your silo's capacity up to 30%. And we can provide



Volumaxx™ unloader. Expect the best from the leader.

9" & 11" Single Chain Conveyors



MOVE TONS OF FEED FAST & EFFICIENTLY

Now get the best of Jamesway®, Van Dale® and Starline® in J-STAR'S high capacity single chain feed conveyors. Available in 9" and 11" models to match distances up to 150', their belt and chain reduction drive is factory pre-assembled for easy installation. The 9" conveyor has #62 steel chain with metal backed rubber flights; 11" has 667H pintle chain and rubber flights. Both models also feature safety/service shutoff switch conveniently located on conveyor drive.

For high capacity feed conveying that offers you built-in flexibility, look no further than the one name that says it all - J-STAR.

VERTICAL PUMP

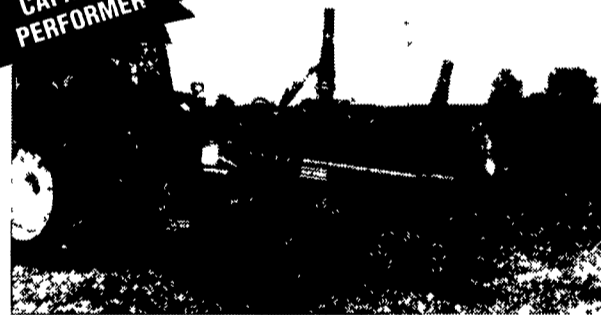

2-POINT HITCH MOUNTED

Tough, rugged and reliable...

See what a REAL Van Dale vertical pump can do!

THESE FEATURES MEAN MORE BENEFITS FOR YOU! CHECK 'EM OUT!

- All hydraulic controls
- Remote hydraulic controls
- 270° horizontal nozzle control
- 45° vertical nozzle control
- 20" diameter impeller
- 100 H.P., 540 or 1000 RPM
- Two discharge nozzles for complete agitation
- Available in 8', 10' and 12' models
- Oil bath lower bearing & seal assembly for long life, low maintenance

• **CABLE ALLEY SCRAPER**

• **WASTE HANDLING EQUIPMENT**
DUMPS - TANKS - TILLAGE APPLICATOR

• **FEED HANDLERS**
BELTS - FEEDERS - CONVEYORS

J-STAR
Visit our Website!
www.j-star.com

See These Dealers For J-Star Financing Programs Available Now!

FRANKLIN'S FARM SERVICE
Laceyville, PA 570-869-2407

HOOVER EQUIPMENT
Tyrone, PA 16686
814-684-1777

LAPP'S BARN EQUIPMENT SALES & SERVICE
Gap, PA 17527
717-442-8134

SOLLENBERGER SILOS CORP.
Chambersburg, PA 17201
1-800-909-6909

STAR SILOS
Myerstown, PA 17067
1-800-909-6909

AGRI EQUIPMENT
Myerstown, PA 17067
717-866-0200

JAMES L. HOSTETTER
McVeytown, PA 17051
717-899-6386

ROVENDALE AG & BARN EQUIPMENT
Watsonstown, PA 17777
570-538-9564

SOMERSET BARN EQUIPMENT
Somerset, PA 15501
814-445-5555

MARYLAND

GLADHILL TRACTOR MART
Frederick, MD 21701
301-663-6060

HISTAND'S FARM & HOME SERVICE
Rome, PA 570-744-2371