

VISIT OUR EXHIBIT AT KEYSTONE FARM SHOW - JAN. 7, 8 & 9

J-STAR

America's Best!

**MAGNUM II™
SURFACE DRIVE SILO UNLOADER**

America's best selling silo unloader just got better! Van Dale's been writing the book on silo unloading technology for more than 45 years. And Van Dale invented and perfected the surface drive unloader. Now it's time to introduce the next generation. The MAGNUM II!
The new MAGNUM II features a brand new Hi-Perform™ Impeller which adds more "throw-power" than ever before. Check it out and then check in with your Van Dale Dealer.

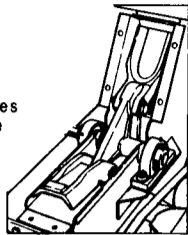

CHECK OUT THESE FEATURES

- ✓ Full 1/4" stainless steel back wrapper
- ✓ Formed 10-gauge stainless steel discharge area
- ✓ Adjustable 1/4" abrasion resistant cut-off plate
- ✓ Easy-access inspection cover
- ✓ 27" impeller

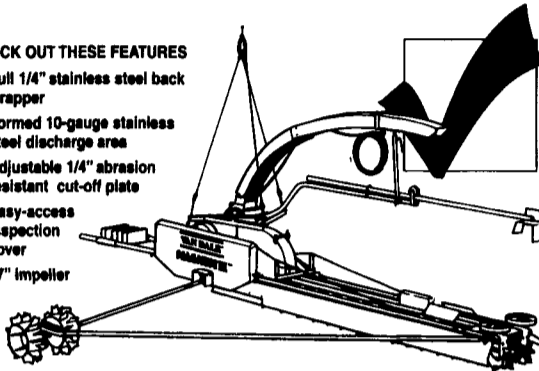

**THE VAN DALE
ADVANTAGE**

Contact your local dealer for details!

VAN DALE Dependability through Quality

Silo Unloader Technology Takes a Giant Leap Forward!

**BIG JIM. Quantum™
SYSTEM**

**TOWER
SILOS
REALLY
MEASURE
UP!**

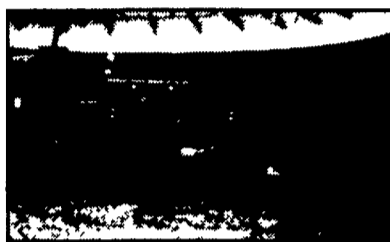

Measure for measure, nothing beats a tower silo for storing forage. Just compare them to bunkers which have up to 45% storage loss, lower capacity, increased labor and lots of inconvenience.

Towers lose just 3% to 7% because of gravity, feed weight and a good unloader like the Big Jim QUANTUM System.

QUANTUM can be installed in any type of 20' to 30' forage silo. conventional or oxygen limited and will make your tower silo even better!

CALL US TODAY FOR A VIDEO AND BROCHURE

The Silo Unloader Experts



**LEASE IT TODAY WITH
ONE PAYMENT DOWN!**

**VOLUMAXX
GIVES YOU
A CHOICE OF
DISTRIBUTION**

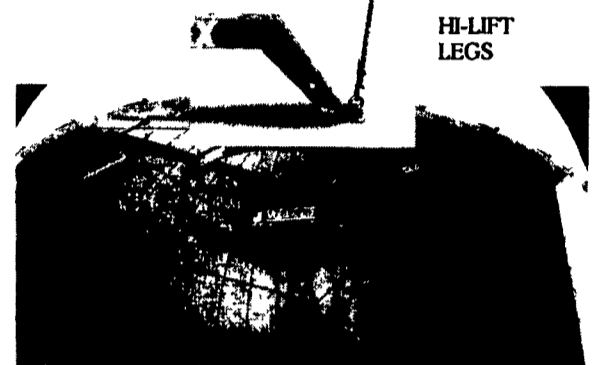

**HI-LIFT
LEGS**

The new advance design Volumaxx unloader gives you the best of both worlds.. your choice of distribution. New HI-LIFT legs let you raise the unloader an extra 15" into the silo roof, so you can use a conventional side

distributor. Or, choose the Jamesway Powermaxx™ broad pan silage distributor. With proper distribution, you'll have better quality feed, and you'll increase your silo's capacity up to 35%. And we can prove it!



Volumaxx™ unloader. Expect the best from the leader.

**9" & 11"
Single
Chain
Conveyors**

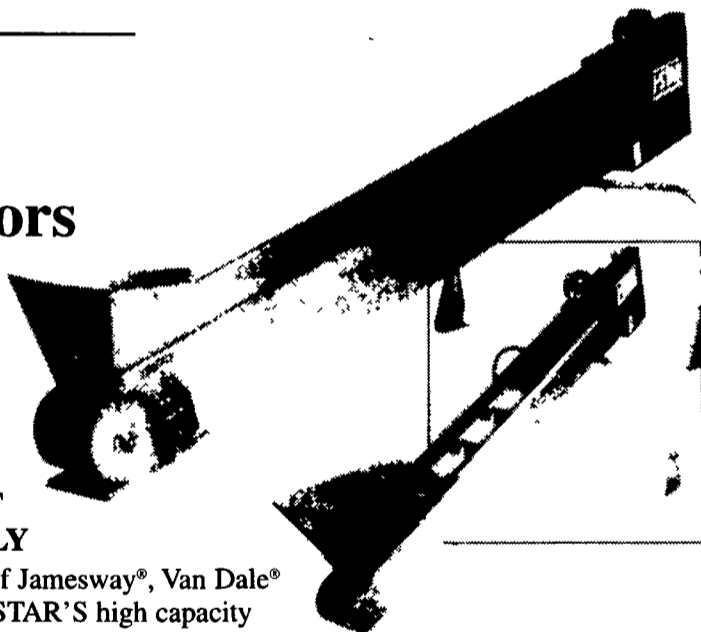

**MOVE TONS
OF FEED FAST
& EFFICIENTLY**

Now get the best of Jamesway®, Van Dale® and Starline® in J-STAR'S high capacity single chain feed conveyors. Available in 9" and 11" models to match distances up to 150', their belt and chain reduction drive is factory pre-assembled for easy installation. The 9" conveyor has #62 steel chain with metal backed rubber flights; 11" has 667H pintle chain and rubber flights. Both models also feature safety/service shutoff switch conveniently located on conveyor drive.

For high capacity feed conveying that offers you built-in flexibility, look no further than the one name that says it all - J-STAR.

VERTICAL PUMP



**2-POINT HITCH
MOUNTED**

Tough, rugged and reliable...

See what a REAL Van Dale vertical pump can do!

**THESE FEATURES MEAN MORE BENEFITS FOR YOU!
CHECK 'EM OUT!**

- All hydraulic controls
- Remote hydraulic controls
- 270° horizontal nozzle control
- 45° vertical nozzle control
- 20" diameter impeller
- 100 H.P., 540 or 1000 RPM
- Two discharge nozzles for complete agitation
- Available in 8', 10' and 12' models
- Oil bath lower bearing & seal assembly for long life, low maintenance

- **CABLE ALLEY**
- **WASTE HANDLING EQUIPMENT**
- **FEED HANDLERS**
- **SCRAPER**
- **DUMPS - TANKS - TILLAGE APPLICATOR**
- **BELTS - FEEDERS - CONVEYORS**

See These Dealers For Details Now...

**FRANKLIN'S
FARM SERVICE**
Laceyville, PA 570-869-2407

HOOVER EQUIPMENT
Tyrone, PA 16686
814-684-1777

**LAPP'S BARN EQUIPMENT
SALES & SERVICE**
Gap, PA 17527
717-442-8134

**SOLLENBERGER SILOS
CORP.**
Chambersburg, PA 17201
717-264-9588

STAR SILOS
Myerstown, PA 17067
717-866-5708

HARRY TROOP
Cochranville, PA 19335
215-593-6731

JAMES L. HOSTETTER
McVeytown, PA 17051
717-899-6386

**ROVENDALE AG & BARN
EQUIPMENT**
Watson, PA 17777
570-538-9564
570-742-4226

**SOMERSET BARN
EQUIPMENT**
Somerset, PA 15501
814-445-5555

**MARYLAND
GLADHILL TRACTOR MART**
Frederick, MD 21701
301-663-6060

**HISTAND'S FARM & HOME
SERVICE**
Rome, PA 570-744-2371