

CONGRATULATIONS: DAIRY OF DISTINCTION WINNERS

J-STAR

YOUR ALL-IN-ONE FARMSTEAD EQUIPMENT SOURCE

HEAVYWEIGHT MIXERS THAT ARE GENTLE ON FEED

Climb into the ring with Roto-Mix®, the reigning heavyweight champ of feed mixers. Far heftier than its lightweight competition, all Roto-Mix mixers are extremely gentle on feed for a fresher, fluffier ration with better clean out and lower horsepower requirements. Call today for a demo. You'll see when it comes to mixing sound after round of feed, Roto-Mix is a winner.

Series IV & Commercial Feed Mixers Trailer, truck and stationary units. Mixing capacities: Series IV, 80 to 520 cu. ft.; Commercial, 420 to 900 cu. ft.

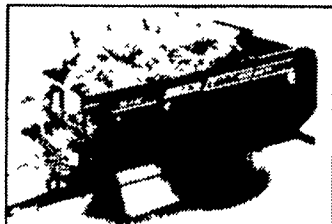

ROTO-MIX
A Division of J STAR Industries, Inc



Bale Cutter (above, left)
The fast, easy and economical way to cut "big" round bales or baleage for TMR.

Vertical Feed Mixers (above, right)
The reigning champs for really tough forage rations, including big bales. Mixing capacities from 355 to 855 cu. ft.

• Cable Alley Scraper

• Waste Handling Equipment

- Pumps
- Tanks
- Tillage Applicator

• Feed Handlers

- Belt Feeders
- Conveyors

Silo Unloader Technology Takes a Giant Leap Forward!

BIG JIM. Quantum SYSTEM

SIMPLY THE BEST!

You know tower silos are the best way to store feed. Now Jamesway® gives you the best way to fill and feed fast, with great reliability. Plus, you get:

- Better Feed Quality
- More Feed Storage
- A Clean Chute

The all-new industrial-design Big Jim QUANTUM System can be installed in any type of 20' to 30' forage silo. . . conventional or oxygen limited. And since it requires little maintenance and has no doors to change, you eliminate trips up and down the silo.

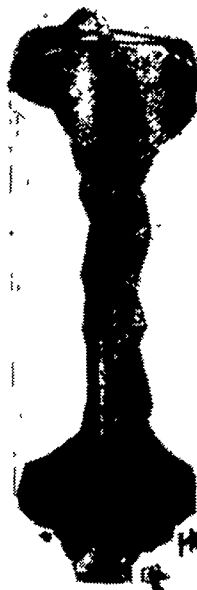

The Silo Unloader Experts



Lease It Today

LEASE IT TODAY WITH ONE PAYMENT DOWN

OSWALT
Mixers by J-STAR



Be a Total Mixed Rations champion with Oswalt® four auger mixers. Choose from 12 heavy duty models with capacities from 150 to 950 cu ft. Each helps you get the best feed conversion. The best feed utilization. And the best herd health and performance.

Plus, no other mixer -- reel type or auger -- gives you the endless opportunity to make the best use of every feed source -- including baled hay. And no other mixer is built as strong as an Oswalt.

Ask your Oswalt Dealer for a demo. Take a good look at how Oswalt mixers can make your livestock a herd of champions. Then you'll see what we mean when we say

Oswalt's New Hay Saw™ Processor
Effortlessly cuts through long stemmed hay, converting it into a thoroughly blended TMR. Save time, fuel and money and extend auger life.

Perhaps the most revolutionary idea since TMR. Available on most Oswalt Models.

Nothing Performs Like an Oswalt!

VAN DALE WASTE HANDLERS VERTICAL PUMP

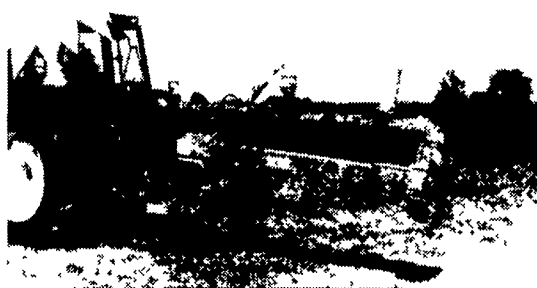

2-POINT HITCH MOUNTED
THESE FEATURES MEAN MORE BENEFITS FOR YOU! CHECK 'EM OUT!

- All hydraulic controls
- Remote hydraulic controls
- 270° horizontal nozzle control
- 45° vertical nozzle control
- 20' diameter impeller
- 100 H.P., 540 or 1000 RPM
- Two discharge nozzles for complete agitation
- Available in 8', 10' and 12' models
- Oil bath lower bearing & seal assembly for long life, low maintenance

"Pow'R" To Burn!

WITH THE NEW POW'R-RING™ UNLOADER

Van Dale's new POW'R RING unloader has power to burn when it comes to taking on the toughest hard packed or even frozen silage. When other unloaders melt down that's when the POW'R RING silo unloader gets down -- down to business with the best unloading performance available anywhere.

But what else would you expect from America's most popular name in silo unloaders? We've put our 45 years of experience to work to build the best ring drive unloader ever. And you'll be glad we did!

- CHECK OUT THESE FEATURES
- ✓ Choice of Suspension Packages
 - ✓ Heavy 7" Diameter Channel Steel Drive Ring
 - ✓ Free-Floating Drive System
 - ✓ Hi-Perform™ Impeller

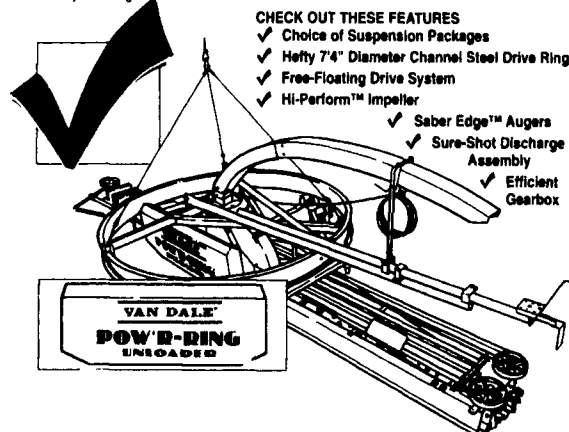

- ✓ Saber Edge™ Augers
- ✓ Sure-Shot Discharge Assembly
- ✓ Efficient Gearbox

See These Dealers For Details Now...

FRANKLIN'S FARM SERVICE
Laceyville, PA 570-869-2407

LAPP'S BARN EQUIPMENT SALES & SERVICE
Gap, PA 17527 717-442-8134

WIGGERS FARM EQUIPMENT
Cory, PA 814-664-2661

SOLLENBERGER SILOS CORP.
Chambersburg, PA 17201 717-264-9588

STAR SILOS
Myerstown, PA 17067 717-866-5708

HARRY TROOP
Cochranville, PA 19335 215-593-6731

JAMES L. HOSTETTER
McVeytown, PA 17051 717-899-6386

ROVENDALE AG & BARN EQUIPMENT
Watsonstown, PA 17777 570-538-9564 OR 570-742-4226

SOMERSET BARN EQUIPMENT
Somerset, PA 15501 814-445-5555

MARYLAND
GLADHILL TRACTOR MART
Frederick, MD 21701 301-663-6060

HOOVER EQUIPMENT
Tyrone, PA 16686 814-684-1777