

**1 FARM EQUIPMENT**

There is an Alternative Building for you. Steel arch & fabric style buildings. Equipment storage, free stall barns, calf barns, riding arenas, etc. See our display ad under Building & Supplies. John E Weaver, 570/672-2213.

Potato equip: 2R McConnell-Utah harvester, some belted chain, sterrable axle, hydro drive, field ready. 2R Lockwood windrower, steerable axle, field ready. Delivery possible. 814-590-6395

NH 565 skid loader, 1300 hrs, good cond, \$8900. 717-354-6829

255 MF diesel, 3pt hitch, 1 remote, ex cond, \$7500. 570-286-7851

JD 535 sprayer, 30' boom, hyd pump, 350 gal tank, new tires, \$2,500. LanCo, 717-898-9492.

JD 4030, good condition, only 4500 hrs, must sell! \$8000. 814-448-2188

JD 825 6R cultivator, like new, used 1 season, \$1100 OBO. 419-752-2704

Ford 555A loader 4x4, good cond., \$8900; Also 555 loader, \$6500; Also used skid steers arriving each week. Zeisloff Eq. 800-919-3322

SAWMILL \$3,895. Free information. Norwood Industries, 252 Sonwil Dr, Buffalo, NY, 14225. 1-800-661-7746, ext 407.

Case tractor, 1950 orchard model, completely restored, new rubber, \$2,500. 610-944-6940.

Case 1840, 2001 model, w/72" material bucket, exc cond. 717-762-3861.

Dump wagon, \$650; Complete irrigation system. Approx. 4500' of 4" & 6" pipe, T's, shut-offs, elbows, risers, sprinklers, pipe cart, Gorman Rupp pump, \$5,500. 300 gal. John Beam SS spray tank w/agitation, \$2,000. 4R AC corn planter w/plates, fert. attach, \$300, 2R Transplanter \$200. 570/693-0695

NH 553 skid loader, 2300 hrs, \$5900. 717-354-6829

**EVERITT EQUIPMENT Ringoes, NJ 908-782-5283 After 6 P.M.**

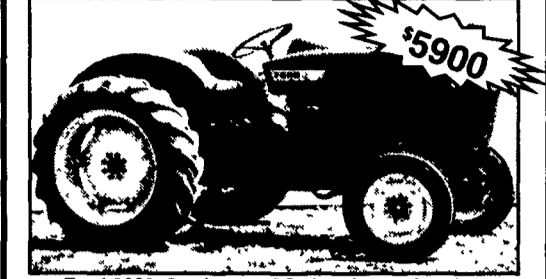

- Ford 2000, 3 cyl., gas, PS, 4 spd., repainted, exc
- Kubota B7100, 4WD, hydro, 700 hrs, excellent **SOLD** \$9,500
  - Kubota L2250, 26 HP, 4WD, PS Loader, Turf Tires, Runs & Operates Nice \$10,995
  - MF 202 w/loader, power steering, gas, 3 pt., PTO, runs good \$5,500
  - MF 35 gas 3 pth PTO power steering, orig good tractor \$4,000
- Collectors**
- JD B Cyclone, ex cond, rubber like new \$3,000
  - JD 110 (1965) lawn tractor w/ attachment, runs great, a **SOLD** \$995
  - JD 620 PS, factory 3 pth, low runs good, needs paint. **SOLD** \$4,000 \$3750

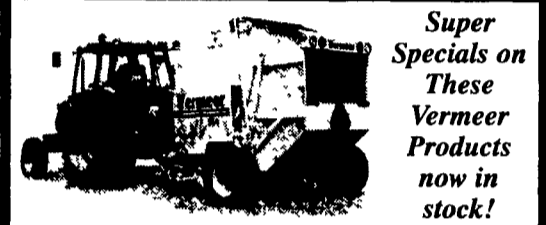

**Super Specials on These Vermeer Products now in stock!**

- 554XL with Net Wrap
- 554XL Auto Tie
- BP7000 Bale Processor
- WR20 Rakes
- 6084 Rock Picker Rental

**Schulte**

- XL 1500 Rotary Cutter
- F10 Rotary Cutter

**Sukup**

- 2050 No-Till Drill 7' w/12 volt Lift Pump

**Krone**

- KWT 1050 Tedder 34.5'

**Used**

- Hesston #1160 12 Hydro Swing
- Elko Bale Wrapper Self Load
- Kuhn 23' Hyd Fold Tedder
- Bar Rakes - New Holland, John Deere, International

**TRIPLE H EQUIPMENT**  
Wakefield PA  
717-548-3775  
800-675-2019 tripleh@epix.net  
Fax 717-548-4079  
http://triplehequipment.com



**JD 2955 hi-lo, 3 hydraulics, 18.4x38 tires, real nice. \$23,800**  
Fox Farms, Lebanon Co.  
717-867-5633 717-827-5534

- **Hardi 500 Gal. Single Axle, Loaded, 45' VG., Manual Fold.**
- Blowers**
- Fine Selection of VG-Ex Blowers, Stored Inside & Ready
- NH 28's • NH 40
- Spreaders**
- NH 680 Spreader Tailgate, 2 Btrs, exc
  - NH 680 Spreader Tailgate, 1 Btr, VG
  - Meyer 3245, Rear Discharge Spreader, 400+ Bu, VG
  - NI 3632 Spreader, Tailgate, 2 Btrs., VG
- Other Very Good Equipment**
- H&S 16 Wheel Hyd. Fold Rake, VG, 27'-30'
  - NH 258 Rake, VG, Tripple Teeth, Dolly
  - JD 3 Bu. Seed Boxes, VG Cond. w/Lids, Fits 7000 & Kinze
  - JD 7200 4RN Dry, unit mtd, rebuilt, loaded, compare w/new
  - JD 7000 4RN Liquid, will be rebuilt, frame mtd
  - IH 60 Shredder 1000 RPM, All New Flails
  - Badger 14 Ton Running Gears - Ex., Low Usage
  - Brady 12' Flail Shredder
- Duffield Agri-Service**  
11199 Welsh Run Rd., Greencastle, PA 17225  
**717-328-2336**

**Black Rock Repair**

MANUFACTURER OF FARM & HOME SPRAYERS TRAILER, 3 PT HITCH AND HORSE DRAWN SPRAYER PRODUCE HIGH PRESSURE BOOM SPRAYER SPRAYER PARTS AND SERVICE PRESSURE WASHER - HYDRAULIC HOSES (BLACK WALNUT CRACKER)

858 Pumping Station Road, Kirkwood, PA 17536 **LeRoy B. King 717-529-6553**

**FORRESTER FARM EQUIPMENT LTD.**  
1475 Orchard Rd. Chambersburg, PA 17201  
Phone: 717-263-0705  
Sales-Parts-Service  
Located 1 Mile Off New Exit 20, On I-81, On 696 North To Orchard Rd.  
Hours: 8:00-5:00 Mon. Thru Fri. 8:00-12:00 Saturday  
www.forresterfarmeq.com

**USED EQUIPMENT**

TRACTORS NON CAB	TRACTORS CAB
Ford 5610	NH TS110, 4WD, Cab & Ldr.
Ford 3230 w/Ldr	NH TS110, 2WD, Cab
IH 986, 4 Post	Ford 8970, 4WD
IH 424 <b>SOLD</b>	Ford 8770, 4WD
JD 5020	Ford 8730, 4WD, Pwr. Shift
Case 385 w/Ldr.	Ford 8670, 4WD
	Ford 7610, 4WD

COMPACT TRACTORS	SKID LOADERS
Ford 1720, Bad Engine	NH LX985
Ford 1320 w/Ldr. & Mower	(2) NH LX885
	(2) NH LS 180
	NH LS 160
	NH L565
	Dresser 530 Pay Ldr.

**HAY EQUIP.**

- NH 326 Square Baler
- NH 853 Rd. Baler
- NH 166 Inverter
- NH 41 **SOLD**

**MISCELLANEOUS**

- NH 155 Spreader
- Befco Tedder
- Befco 5 Whl. Rake

**THURS., AUGUST 8**

**Binkley & Hurst Bros., Inc. - Lititz, PA**

**2002 PLANTER CLINIC & FIELD DAY**

Featuring: **KEN FERRIE - Back by Popular Demand!**  
**PLAN NOW TO ATTEND!**

**NOW IS A GREAT TIME TO PURCHASE A NEW PLANTER AT OLD PRICE SAVINGS! KINZE PLANTERS IN STOCK AT BINKLEY & HURST BROS. INC. FOR CORN OR BEANS - Corn OR Soybeans -**

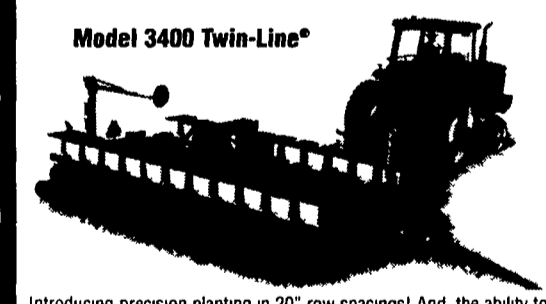

Model 3400 Twin-Line®  
Introducing precision planting in 20" row spacings! And, the ability to plant ultra-narrow 10" or 11" rows with the KINZE® Interplant® System Plus, in-line transport as narrow as 11"3" (12' 7" with the Interplant® Package and no till coulters)

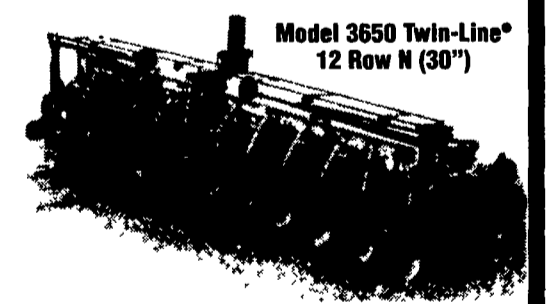

Model 3650 Twin-Line® 12 Row N (30")  
Narrow Transport Model. Onboard bulk fill distribution system for unparalleled efficiency

**KINZE Seed Meters**

**The Most Accurate And Dependable Seed Metering Systems In The Field! For Corn.**

- **Highly accurate. The KINZE® Finger Pickup Metering System delivers unequalled spacing for your valuable corn crop**
- **Reliable. Convenient. No plates or seed discs to change when planting different seed corn sizes or shapes. And, you have none of the adjustments required with air or vacuum systems!**
- **Economical. Gives years of low-cost low-maintenance service**

**Make every seed count!**

**Precision Metering For Soybeans, Milo & Cotton.**

This is the patented, mechanical brush-type seed meter that precisely singulates every soybean, milo/grain sorghum and acid-delinted cotton seed with pinpoint accuracy. Gentler on the seed than anything you've ever used before. Easy to maintain - just one moving part. Best of all it fits most "plateless" planters in the field today!

Seed discs available for soybean, milo/grain sorghum and acid-delinted cotton. We'll help you choose the one that fits your operation.

\*KINZE® Brush-Type Seed Meters. It all KINZE®. "Plateless" Planters. See your KINZE® Dealer for additional information. Discover the simplicity and accuracy of the KINZE® Brush-Type Seed Meter System today!

**IN STOCK AT BINKLEY & HURST BROS. INC. NEW SELF PROPELLED DISC MOWER CONDITIONER**

**BINKLEY & HURST BROS. INC.**  
133 Rothsville Station Rd  
P O Box 0395, Lititz, PA 17543-0395 (717) 626-4705  
Located 1/2 Mile North of Rothsville 1-800-414-4705 Fax 717-626-0996

Visit our Web Site at <http://www.caseih.com>  
Case IH and Case credit are registered trademarks of Case Corporation

**CASE IH**  
A TRADITION OF LEADERSHIP

**3400 MODEL**

20" or 10" Row Crops Transport at 12'7"

**BINKLEY & HURST BROS. INC.**

133 Rothsville Station Rd.  
P.O. Box 0395, Lititz, PA 17543-0395  
(717) 626-4705 1-800-414-4705 Fax (717) 626-0996