

Shippensburg Hay Auction

Shippensburg, Pa.
Report Supplied By Auction
June 22 and 25, 2002
Hay—Straw—Grain

27 LOADS.
ALFALFA: 120.00.
MIXED HAY: 32.00-150.00.
TIMOTHY: 40.00-116.00.
CLOVER: 32.00.
BROMEGRASS: 78.00.
ORCHARDGRASS: 30.00-110.00.
STRAW: 70.00-112.00.
MULCH: 20.00-25.00.

Vintage Hay

Vintage, Pa.
Report Supplied by Auction
Thursday, June 27, 2002
Hay—Straw—Grain
MIXED HAY: 62.00-75.00.
BARLEY STRAW: 110.00.

Westminster Hay

Westminster, Maryland
Report Supplied By Auction
Tuesday, June 25, 2002
Hay—Straw—Grain

126 LOTS.
ALFALFA: .75-3.00 BALE.
TIMOTHY: 1.50-2.90 BALE.
MIXED HAY: 1.40-3.40 BALE.
GRASS: .75-1.90 BALE, 9.00-17.00
LARGE ROUND.
STRAW: .90-2.00 BALE.
MULCH: .05-.60 BALE.
OAT HAY: .10-1.00 BALE.

Livestock Cooperative Auction Market Of North Jersey

Hackettstown, N.J.
Report Supplied by Auction
June 25, 2002
Hay—Straw—Grain

ALFALFA: 3 LOTS, 1.60-2.50 BALE.
MIXED HAY: 18 LOTS, .50-2.40 BALE.
TIMOTHY: 3 LOTS, .50 BALE.
ALFALFA OATS: 5 LOTS .50-.80 BALE.
GRASS: 8 LOTS, .50-2.10 BALE.
RYE STRAW: 2 LOTS, 1.40.
EAR CORN: 1 LOT AT 1.50.
GROUND CORN: 1 LOT AT 3.50.
SHELLED CORN: 1 LOT AT 2.00.
42 LOTS TOTAL.

Weaverland Hay

New Holland, Pa
Report Supplied By Auction
Thursday, June 27, 2002
Hay—Straw—Grain

31 LOADS.
ALFALFA: 80.00.
TIMOTHY HAY: 85.00-110.00.
MIXED HAY: 40.00-195.00.
GRASS: 95.00.
STRAW: 90.00-125.00.
EAR CORN: 89.00.
OATS: 2.30 BU.
FIREWOOD: 57.00 LOAD.
LONG LANE ROAD, NEW HOLLAND 17557, 717-355-0834.

East Fluid Milk And Cream Review

Madison, Wis.
June 26, 2002
Report Supplied by USDA
Spot prices of class II cream, dollars per lb. butterfat: F.O.B. producing plants: Northeast: 1.2982-1.3996. Delivered Equivalent: Atlanta: 1.2982-1.4199 mostly 1.3185-1.3793.

PRICES OF CONDENSED SKIM, dollars per lb. wet solids, F.O.B. producing plants: Northeast: Class II, includes monthly formula prices: 9200-1.0250; Class III - spot prices - .7500-.9600.
SPOT SHIPMENTS OF GRADE A MILK: FLORIDA: This week - In 0, Out 96; last week - In 0, Out 32; last year - In 0, Out 75. SOUTHEAST STATES: This week - In 0, Out 0; last week - In 0, Out 0; last year - In 0, Out 0.

Weather continues to play a major role in milk output in the East. Continued rains in the far north are making first cutting alfalfa difficult to harvest and some fields have been left fallow because they are too wet to plant. Much of the region from the Northeast to Florida is experiencing very hot weather and the milk flow is being adversely affected. However, Florida's milk output is reported to have rebounded as the state is getting some much needed rain and the evenings are not as hot as they have been. This, along with much slower Class I demand, has forced nearly 100 loads of milk out of state for processing. This is a significantly higher number than a week ago and surprised many contacts.

As is normal, the effects of the hot weather are seen in lower fat and protein levels. Class I sales are steady at slow levels in nearly all areas of the East. Surplus milk supplies are heavier in the Southeast; steady to slightly lower in the more northern areas. Contacts are making ar-

rangements for next week when some manufacturing plants will be down for various periods of time.

The condensed skim market is basically steady. Some prices for July Class III sales are expected to be up slightly based on estimates of the July Class III skim milk price.

The fluid cream market started the week on the weak side, but firmed up by midweek. Supplies were long, but did tighten significantly as users try to step up output before they shut down during the holiday weekend. Reports indicate that several cream cheese operations will not take cream most of next week which will impact availability. Also, several ice cream plants have notified supplies that they will be down from the fourth to the seventh. This week, spot prices are virtually unchanged from last week. Multiples were occasionally lower, but mostly in the mid to upper 130's. Demand is reported as mixed. Ice cream output is at normal summer levels and the hot weather is helping consumption of soft serve and frozen novelties. Bottled cream sale are starting to slow as most of the strawberry season is past. Cream cheese output is moderate to heavy this week. Churning activity is lighter.

Dairy Products Prices Highlights

Washington, D. C.
June 21, 2002

Report Supplied By NASS/USDA
DAIRY PRODUCTS PRICES HIGHLIGHTS:

CHEDDAR CHEESE prices received for US 40 pound Blocks averaged \$1.17 per pound for the week ending June 15. The price per pound decreased 1.1 cents from the previous week. The price for US 500 pound Barrels adjusted to 38 percent moisture averaged \$1.14 per pound, down 2.0 cents from the previous week.

BUTTER prices received for 25 kilogram and 68 pound boxes meeting USDA Grade AA standards averaged \$1.05 per pound for the week ending June 15. The U.S. price per pound increased 0.3 cents from the previous week.

NONFAT DRY MILK prices received for bag, tote and tanker sales meeting USDA Extra Grade or USPH Grade A standards averaged 90.1 cents per pound for the week ending June 15. The U.S. price per pound decreased slightly from the previous week.

DRY WHEY prices received for bag, tote and tanker sales meeting USDA Extra Grade standards averaged 16.5 cents per pound for the week ending June 15. The U.S. price per pound decreased 0.2 cents from the previous week.

North Atlantic Eggs

Atlanta, Georgia
Report Supplied by USDA
June 27, 2002

In Philadelphia, prices were unchanged to 2 cents lower on all sizes. In Boston, prices were unchanged to 1 cent lower on all sizes. Prices paid to producers in New England were 2 cents lower on extra large and large, unchanged on the balance of sizes. The market tone ranged barely steady to weak. Demand was mostly light to moderate. Supplies were adequate to available. Breaking stock offerings were adequate to ample for the fair demand. Light type fowl were fully sufficient to ample.

PHILADELPHIA: PRICES TO RETAILERS, SALES TO VOLUME BUYERS, USDA GRADE A AND GRADE A, WHITE EGGS IN CARTONS, DELIVERED STORE DOOR, CENTS PER DOZEN. RANGE: EXTRA LARGE .59-.69, LARGE .58-.67, MEDIUM .49-.55

BOSTON: PRICES TO RETAILERS, SALES TO VOLUME BUYERS, USDA GRADE A AND GRADE A, BROWN EGGS IN CARTONS, DELIVERED STORE DOOR, CENTS PER DOZEN. RANGE: EXTRA LARGE .97-1.01, LARGE .90-.94, MEDIUM .71-.74

NEW ENGLAND: PRICES PAID TO PRODUCERS, CASES EXCHANGED, GRADE YIELD BASIS, BROWN EGGS LOOSE, AT FARM, CENTS PER DOZEN. RANGE: JUMBO 1.17-1.20, EXTRA LARGE .76-.79, LARGE .69-.72, MEDIUM .52-.55, SMALL .25-.28

Pa. Grain Report

June 24, 2002

Report Supplied By PDA

COMPARED WITH LAST MONDAY'S MARKET FOR EASTERN AND CENTRAL PENNSYLVANIA: Corn mostly steady, spots .05 higher. Wheat steady to .07 lower as harvest approaches. Barley steady to .05 lower as harvest continues. Oats and Ear Corn mostly steady. Soybeans mostly .07 to .10 lower. PRICES PAID DELIVERED TO DEALERS DOCK, All prices per bushel, except Ear Corn per ton.

SOUTHEASTERN PENNSYLVANIA
CORN No. 2-y, 2.30-2.45 few to 2.55,

avg. 2.41; contract for harvest 2.27-2.38. WHEAT No. 2, 2.82-3.27, avg. 2.98; contract for harvest 2.74-3.07. BARLEY No. 3, 1.35-1.50, avg. 1.43. OATS No. 2, 1.85-2.40, avg. 2.08; contract for harvest 1.50. SOYBEANS 4.74-5.00, avg. 4.85; contract for harvest 4.74-5.00. Gr. Sorghum, 2.21. Ear Corn 63.00-75.00, avg. 69.75.

SOUTH CENTRAL PENNSYLVANIA

CORN No. 2-Y, 2.30-2.40, avg. 2.36; WHEAT No. 2, 2.60-2.80, avg. 2.67; BARLEY No. 3, 1.20-1.40, avg. 1.34; OATS No. 2, 1.70-1.80, avg. 1.75; SOYBEANS No. 1, 4.50-4.60, avg. 4.53. EAR CORN 60.00-75.00, avg. 68.00.

WESTERN PENNSYLVANIA

CORN No. 2, 2.05-2.40, avg. 2.31; WHEAT No. 2, 2.50-2.60, avg. 2.56; BARLEY No. 3, 1.50; OATS No. 2, 1.60-1.90, avg. 1.74; SOYBEANS No. 1, 4.85; EAR CORN 67-68.00, avg. 67.50.

CENTRAL PENNSYLVANIA

EAR CORN No. 2, 2.40-2.53, avg. 2.45; WHEAT No. 2, 2.40-2.50, avg. 2.45; BARLEY No. 3, 1.35-1.50, avg. 1.46; OATS No. 2, 1.80-2.10, avg. 1.93; SOYBEANS, No. 1, 4.70-4.73, avg. 4.71; EAR CORN 65.00.

LEHIGH VALLEY

CORN No. 2-Y, 2.40-2.41, avg. 2.40; WHEAT No. 2, 2.82-3.17, avg. 3.03; BARLEY No. 3, 1.40-1.55, avg. 1.45; OATS No. 2, 1.75-1.90, avg. 1.85; SOYBEANS No. 1, 4.70-4.80, avg. 4.76; GRAIN SORGHUM 2.80-2.84, avg. 2.82; EAR CORN 71.00-75.00, avg. 73.00.

EASTERN AND CENTRAL PENNSYLVANIA

CORN No. 2-y, 2.30-2.53, avg. 2.41; month ago 2.35, year ago 2.18. WHEAT No. 2, 2.40-3.27, avg. 2.86, month ago 2.50, year ago 2.34. BARLEY, No. 3, 1.20-1.55, avg. 1.42; month ago 1.77, year ago 1.3. OATS No. 2, 1.70-2.10, avg. 1.91; month ago 1.94, year ago 1.44. SOYBEANS No. 1, 4.50-5.00, avg. 4.76; month ago 4.56, year ago 4.24. EAR CORN 65.00-75.00, avg. 69.11, month ago 67.94, year ago 60.70.

NORTH CENTRAL OHIO

(Prices FOB Truck): CORN 2.06-2.14; WHEAT 2.74-2.80; OATS 1.50; SOYBEAN MEAL: bulk 44% 168.40-172.50; bulk 48% 174.40-180.50.

AGRICULTURE THE GRAIN OF OUR ECONOMY

Storage Bin Sale

Clean up the clutter with plywood storage bins. Store large or small items. Stack bins to keep areas clean. Harvest your crops and ship in plywood bins. Protect your crops with sturdy plywood bins

Ontelaunee Orchards, Inc.

Route 61 • Leesport, PA 19533 • (610) 926-2187 • Hours 8 AM to 4:30 PM

Sturdy Storage Bins

- ✓ Large enough to hold chopped wood for your fireplace
- ✓ Perfect for auto parts or anything you need to sort.
- ✓ Strong enough to hold sharp items without damaging the bin.



BEAT THE HEAT



52" and 36" 6-Paddle Fans

Lots of Other Fans Available - Portable or Stationary

52" Fan: 26,396 CFM @ 401 RPM

Very Quiet Because It Runs Slow.

Excellent For Tunnel Ventilation

Electric & Hydraulic Motors In Stock

Lineshaft Kits Available



343 Christiana Pike
Christiana, PA 17509

Answering Service
1-610-593-2753

INTRODUCING... THE **PSP-30** FARM PACKER

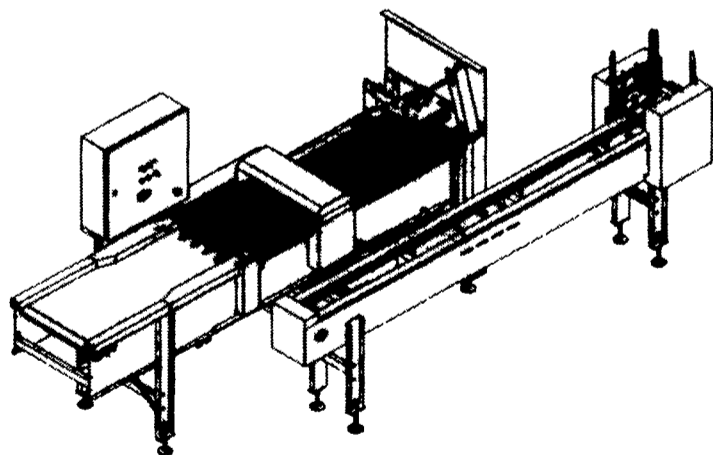

- Available in 50 or 100 Case/Hr Versions
- Easy One Man Operation
- Optional Tray Stackers, Egg Counters and In/Out Conveying
- Let Us Provide A Complete Conveying and Packing Solution



Your Partner in Agri-Business

255 Plane Tree Drive, Lancaster, PA 17602

Toll Free 800-HEC-0988

Fax (717)291-1534

Call Bill Shirey for Details

Website: www.hequip.com

We are open Mon. - Fri. 6:30 a.m. to 5:00 p.m. • Our Service Department is Available 24 Hours a Day