

National Holstein Convention Organizers To Welcome Guests From Across Continent

(Continued from Page A1)

people," Valen said. Included in that team were other NJH-FA members and Rutgers University extension agents, as well as national Holstein personnel and chairpersons from previous national conventions.

Valen said it is an annual tradition for chairpersons past and present to meet and begin planning the following year's convention with the goal of making it "a better event every year."

Recreational tours offered to convention-goers this year include the Statue of Liberty and Ellis Island, Battleship New Jersey and the Aquatic Museum in Camden, dolphin watching, party boat fishing, historic tour of the Trenton battlefields, and Princeton College.

Farm and industry tours will include trips to Atlantic Blueberry Farm; Rutgers Blueberry-Cranberry Research Center; equine horse training and Show Place Farm; Cedar Lane Farm;

Cape May Fisheries; Sheppard Farms, vegetable producers; and others.

A shopping trip to Cape May is also on the schedule.

"We are trying to showcase all of New Jersey," Valen said.

Convention guests will represent practically every state and several foreign countries, including Canada, Mexico, and Argentina.

New Jersey last hosted the National Holstein Convention in 1974.

Dairy One, Pa. DHIA Merger

(Continued from Page A1)

north, according to Jamie Zimmerman, Dairy One general manager.

The company came into existence five years ago when Northeast DHIA and Dairylea Cooperative, Inc., based in Syracuse, N.Y. joined forces. Prior to that, the roots of Dairy One can be traced to the original New York DHIA, formed in the 1940s. In the early 1980s, New York DHIA

had merged with similar associations from New England states to form the Northeast DHIA.

Dairy One offers a range of herd management services in addition to standard DHIA testing. These include forage and manure testing and access to a variety of herd management software. According to Zimmerman, dairy producers can choose to buy as little or as much service as they want from Dairy One.

The company operates milk

testing laboratories in Ithaca, N.Y.; Hagerstown, Md.; and in State College, site of the former Pennsylvania DHIA lab.

Zimmerman said Pennsylvania DHIA technicians will keep their same jobs under Dairy One, while the consolidation will help streamline some administrative duties.

"Our whole focus is to bring value through our services," Zimmerman said.

Kummer Joins Mid-Atlantic Dairy Association Staff

PHILADELPHIA — Jean Kummer recently joined the Mid-Atlantic Dairy Association as a public relations specialist.

In her position, Kummer will provide communications support to the organization by preparing news releases, newsletters, brochures, and other publications. She also will coordinate public relations and consumer events focusing on milk.

Kummer grew up on a dairy farm in Butler County in western Pennsylvania. She was graduated from Penn State in 1992 with a bachelor's degree in agricultural sciences and earned a master's degree from Penn State in 1995 in agricultural and extension education.

Before joining the Mid-Atlantic staff, Kummer worked for the Penn State Cooperative Extension service as a dairy specialist in Beaver, Butler, and Lawrence counties. Her focus was on adult education programs and 4-H dairy youth education.

"We are pleased to have Jean



Jean Kummer

on our staff," said Laura England, director of communications. "She will play a key role in our efforts to promote milk and the many health benefits it provides."

Kummer resides in Blue Bell in Montgomery County.

Mid-Atlantic Dairy Association Launches New Website

PHILADELPHIA — Looking for information about dairy promotion activities in the Mid-Atlantic region? Look no further than www.dairyspot.com, a new Website created by Mid-Atlantic Dairy Association.

Launched in mid-June, the Website features information ranging from classroom activities

and school foodservice ideas to nutrition research and dairy recipes. Teachers, health professionals, and consumers in general will find helpful information about milk and

dairy products and how they can be part of a healthy lifestyle. "In designing dairyspot.com, we focused on the health and nutritional benefits of milk and dairy products," said Laura England, director of communications. "The Website also showcases the many dairy promotion activities we do on behalf of Mid-Atlantic dairy farmers."

In a section titled "Dairy Industry Showcase," dairy farmers can learn more about the dairy checkoff program and how it is working to increase dairy product demand. This section also includes a regular dairy farmer feature designed to tell consumers about life on the farm.

The Website also highlights upcoming activities and promotions and provides relevant contact information for the media.

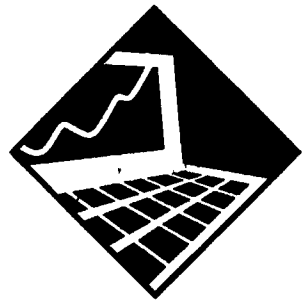

Dairy One

SAVE \$\$ SAVE \$\$ SAVE \$\$ SAVE \$\$ SAVE \$\$ SAVE

SUMMER SPECIAL

5% OFF

YOU WILL RECEIVE 5% OFF OF OUR REGULAR LOW PRICE ON ANY STATIONARY MIXER IF FULL PAYMENT IS MAILED WITH THE ORDER. OFFER MAY BE WITHDRAWN AT ANY TIME.

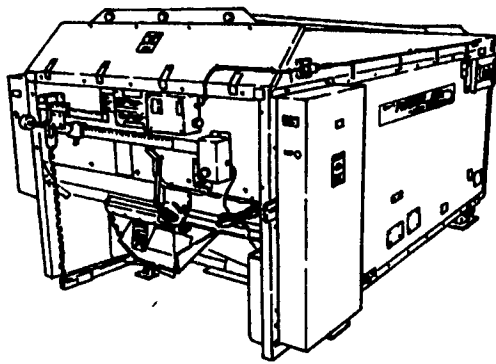

448 Orchard Road
Mohnton, PA 19540
717-484-0551

← I.H. RISSLER
-TMR MIXERS

CAUTION

USE OF THIS MACHINE MAY RESULT IN HIGHER PROFITS

SAVE \$\$ SAVE \$\$ SAVE \$\$ SAVE \$\$ SAVE \$\$ SAVE

JUNE DAIRY MONTH

A Dry Cow Booster That Costs 7¢ a Day

Hoffmans Horse and Cattle Powder is an ideal tonic for cows over freshening. Feed 6 wks. before freshening. 1 Tablespoon a day. (Two weeks over freshening, feed 1 Tablespoon in the morning & 1 Tablespoon in evening)

Cows will clean better after freshening. Cows have a lower somatic cell count and will have less mastitis problems. Great for reproduction tract and cows will cycle better after freshening. Will help rumen function over freshening. Less teat problems and less stress.

This is an over-all good booster if fed to dry cows, and it will pay you big dividends.

- | | |
|--|--|
| Sugar Valley Collar Shop
18 Wagon Wheel Lane
Loganton, PA 17747 | Elvin Zimmerman
18051 Ridgewood Ave
Barnett, MO 65011
573-378-2658 |
| D & J Farm Store
65 Hess Rd
Quarryville, PA 17566 | Bird-In-Hand Farm Supply
200 Maple Ave
Bird-In-Hand, PA 17505 |
| Daniels Farm Store
324 Glenbrook Rd
Leola, PA 17540
717-656-6982 | Gideon F. King
5465 Elam Rd
Kinzer, PA 17535 |
| Gap Repair Shop
994 Gap Rd
Kinzers, PA 17535
717-442-4781 | |

We need more dealers for different areas. If interested, please write to J.L. Hoffman, 183 Stonyhill Rd., Quarryville, PA 17566