

Pysanky Eggs

(Continued from Page B2)

they are in liquid form in wide-mouthed jars they can be saved until the next year. She recommends adding 1/4 tablespoon of vinegar to rejuvenate the dye when it is brought out for its second season.

Mastering the kiska goes a long way toward a beautiful Pysanky egg, according to Swisher.

"I stress the fact that 75 percent of doing these eggs is using the kiska — learning how to control it, heating the wax, and applying it to the egg," she said. Al-

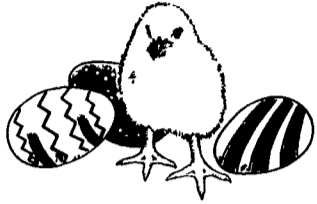

though electric kiskas are available, Swisher prefers the older, candle-warmed model.

Swisher creates the eggs only during the Easter season.

Colors also have meaning as in the following:

- Yellow: light.
- Red: sun, happiness, hope, and passion.
- Orange: everlasting sun.
- Light green: breaking of shackles and freedom from bondage, also spring, new growth, and hope.
- Purple: faith, patience, trust, and fasting.
- Brick: symbol of mother earth bringing forth her bounty.
- Royal blue: royal color, higher life and trust.
- Black: eternity, darkest time before dawn.
- Light blue: signifies the sky with its lifgiving air and good health.

Consuming Thoughts

by

Fay Strickler

Penn State Extension
Home Economist for
Berks Co.



Are you having trouble finding nutritious snacks for your children to eat?

Have you ever wondered about the nutritional benefits of pre-packaged veggies compared to fresh?

Here are a few tips to help you decide what vegetables can fill the menu for your family and help your snacking younger children.

The popularity of pre-cut vegetables packaged in plastic bags is definitely on the rise. Cost notwithstanding, they are very appealing to busy, health-conscious shoppers who'd like to eat more fresh fruits and vegetables but have less and less time to prepare them.

Don't be misled into thinking that ready-to-cook (or eat) vegetables are nutritionally superior.

They should be thought of in the same category as frozen and canned products. All such processed foods, from a practical standpoint, are equally good for you, according to a study reported by the Institute of Food Technologists. By the time you stick the product in your mouth, the nutrient content is about the same regardless of whether it was fresh, frozen, or canned, because in the end, all of these require

different amounts of further processing. With the canned peas for example, they need only be barely heated, while frozen peas require a bit more.

Fresh peas, however, must be shelled, rinsed, and cooked considerably longer. So at some point along the line, all three "versions" have been subjected to about the same amount of heat to make them edible.

In addition, commercial processors typically pick right from the field and preserve the vegetables within hours, allowing less nutrient loss than occurs in that head of broccoli that's been trucked across the country, left to sit in the store for a day or two, taken home, stored even longer, and then overcooked.

Remember-pre-cut vegetables packaged in plastic bags are a "processed" food. First the vegetables are cut, then typically washed in a chlorine solution to kill harmful bacteria, and rinsed in plain water. They're placed in plastic bags that use a technology called "modified atmosphere packaging" to slow down nutrient loss and spoilage. How this works is that the plastic films used in the packages determine the amount of oxygen and carbon dioxide that can move in and out of the bag. Controlling this "respiration" (a natural occurrence that continues even after vegetables have been harvested) maintains nutrient quality significantly longer than if the same product sat out in the open air.

For this reason it's important to note the sell-by date on pre-cut vegetable products and to use them up promptly once the bag has been opened. When the "modified atmosphere" is torn, deterioration accelerates.

Be sure the store displays bagged products in refrigerated cases, similar to those used for chilled orange juice, and keep them cold at home as well, as cold temperature is critical to product quality.

The important thing to remember is eat five servings of fruits and vegetables daily, but it doesn't mean you have to eat garden fresh produce every day.

J-STAR

YOUR ALL-IN-ONE FARMSTEAD EQUIPMENT SOURCE

Silo Unloader Technology Takes a Giant Leap Forward!

BIG JIM. Quantum SYSTEM

SIMPLY THE BEST!

You know tower silos are the best way to store feed. Now Jamesway® gives you the best way to fill and feed from with great reliability. Plus, you get:

- Better Feed Quality
- More Feed Storage
- A Clean Chute

The all-new industrial-design Big Jim QUANTUM System can be installed in any type of 20' to 30' forage silo... conventional or oxygen limited. And since it requires little maintenance and has no door to change, you eliminate trips up and down the silo

CALL US TODAY FOR A VIDEO AND BROCHURE.

The Silo Unloader Experts



America's Best!

MAGNUM II™
SURFACE DRIVE SILO UNLOADER

America's best selling silo unloader just got better! Van Dale's been writing the book on silo unloading technology for more than 45 years. And Van Dale invented and perfected the surface drive unloader. Now it's time to introduce the next generation... The MAGNUM II!

The new MAGNUM II features a brand new Hi-Perform™ Impeller which adds more "throw-power" than ever before. Check it out and then check in with your Van Dale Dealer.

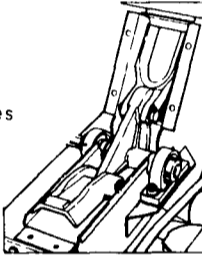

CHECK OUT THESE FEATURES

- ✓ Full 1/4" stainless steel back wrapper
- ✓ Formed 10-gauge stainless steel discharge area
- ✓ Adjustable 1/4" abrasion resistant cut-off plate
- ✓ Easy-access inspection cover
- ✓ 27" impeller

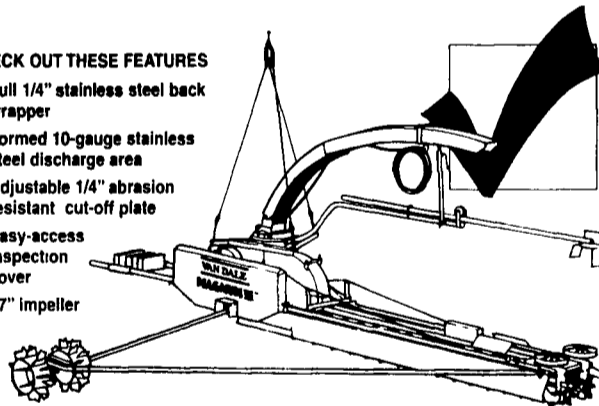

THE VAN DALE ADVANTAGE

Contact your local dealer for details!

VAN DALE Dependability through Quality

- CABLE ALLEY SCRAPER
- WASTE HANDLING EQUIPMENT DUMPS - TANKS - TILLAGE APPLICATOR
- FEED HANDLES BELTS - FEEDERS - CONVEYORS

See These Dealers For Details Now...

FRANKLIN'S FARM SERVICE
Laceyville, PA 570-869-2407

HOOVER EQUIPMENT
Tyrone PA 16686
814-684-1777

WIGGERS FARM EQUIPMENT
Cory PA
814-664-2661

SOMERSET BARN EQUIPMENT
Somerset PA 15501
814-445-5555

HARRY TROOP
Cochranville PA 19335
215-593-6731

LAPP'S BARN EQUIPMENT SALES & SERVICE
Gap, PA 17527 717-442-8134

ROVENDALE AG & BARN EQUIPMENT
Watsontown, PA 17777
570-538-9564
OR 570-742-4226

STAR SILOS
Myerstown PA 17067
717-866-5708

HISTAND'S FARM & HOME SERVICE
Rome, PA 570-744-2371

JAMES L. HOSFETTER
McVeytown, PA 17051
717-899-6386

SOLLENBERGER SILOS CORP.
Chambersburg, PA 17201
717-264-9588

MARYLAND GLADHILL TRACTOR MART
Frederick, MD 21701
301-663-6060

Count With Your Child

When you go on spring walks, look carefully at things along the way. Stop and count:

- Worms on the sidewalk.
- Ants on the ground.
- Flowers in the gardens.
- Clouds in the sky.
- Dandelions in the grass.
- Birds in the trees.



GOT WOOD? WE HAVE THE FURNACE!

- 304 Stainless steel
- No smoke, ashes or wood trash in your home
- 12 hour burn
- Located 10 to 100 feet from your home
- Connects to your existing central duct or hydraulic system

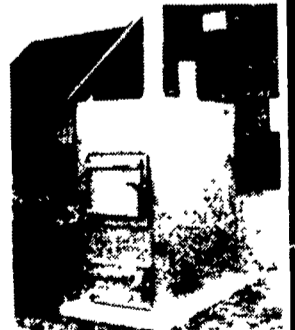

The Hardy Outside Woodburning Heating System Heats Your Home and Household Water

Hardy *10 Year Warranty
OUTSIDE WOODBURNING FURNACE
UL Underwriters Laboratories Inc.
Heating Homes In NY and PA Since 1982

WILLIAMSON ENTERPRISES

330 Williamson Ave., Philadelphia, MS 39350

601-656-2639 Dealers Wanted
877-606-3113