

JD 6810 forage harvester, 1,161 C/H hrs., 1,600 eng. hrs., 0 hrs on new main clutch, comes with 6R Kemper head, inoculant applicator, just serviced & field ready, machine is in PA. **\$110,000 OBO.**  
**(602) 300-9973**  
 leasing/financing available thru Ag Choice Farm Cr

## FOR SALE

Good Used 8' & 9' Baggers  
 Call For Prices! **717-328-3177**

**IH 800**  
 4RN-4RW,  
 dry fertilizer,  
 insecticide,  
 corn & bean drum,  
 monitor, field ready,  
**\$1,500**  
**(717) 354-8263**

## FOR SALE

JD 709 Mower .....\$1,500  
 275 Bushel Gravity Wagon with  
 Extensions and Auger .....\$2,000  
 15 Foot Kawane Cultipacker .....\$2,000  
 10 Foot JD Disc .....\$300  
 John Deere JB-B Drill .....\$1,000  
 5 Shank Sub-soiler .....\$700  
 10 Shank Chisel Plow .....\$1,000  
 Vegetable Sorter and Sizer .....\$500  
 2 Row Mechanical Planter .....\$1,000  
 500 Gal. PTO Sprayer .....\$250

**(732) 297-5748**

## IN STOCK! READY TO WORK!

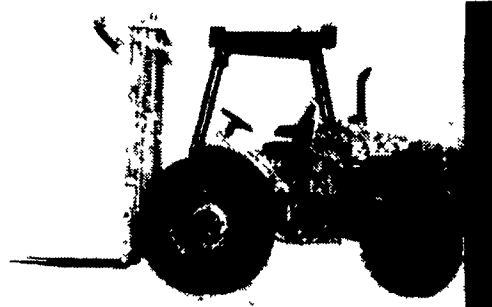

**HARLO PRODUCTS**  
 Introduces the New  
**HD4500**  
**Narrow-Trac Series**  
**Rough-Terrain Forklift**  
 Short Turn Radius

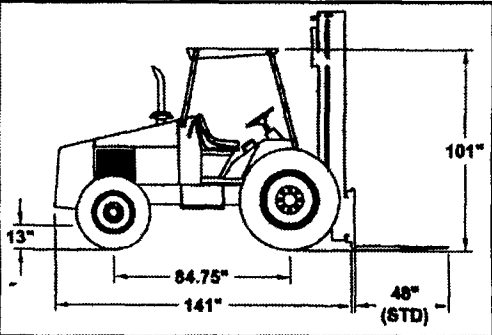
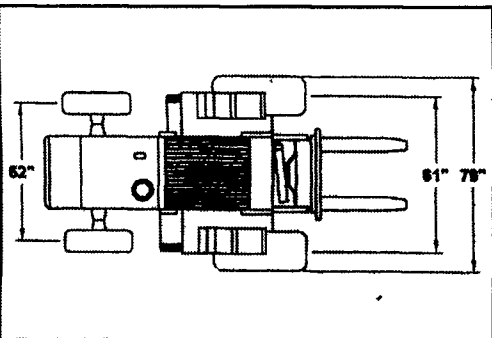

### HARLO HD4500

Cummins 65 HP,  
 2 Wheel Drive, 4500 Lb.,  
 14 Ft. Height Roller Mast  
 Reg. Price \$39,000  
**Sale Price \$29,850**  
 Ask About Financing!

**BINKLEY & HURST BROS. INC.**  
 133 Rothsville Station Rd.  
 P.O. Box 0395, Lititz, PA 17543-0395  
 (717) 626-4705 1-800-414-4705 Fax (717) 626-0996

## BINKLEY & HURST BROS. INC. & KEENAN

**YOU'VE DONE MANY THINGS RIGHT!**  
**IS IT POSSIBLE THAT THE ONLY MISSING LINK IN THE CHAIN OF EVENTS ON YOUR DAIRY IS A KEENAN MIXER?**

### KEENAN TMR MIXER

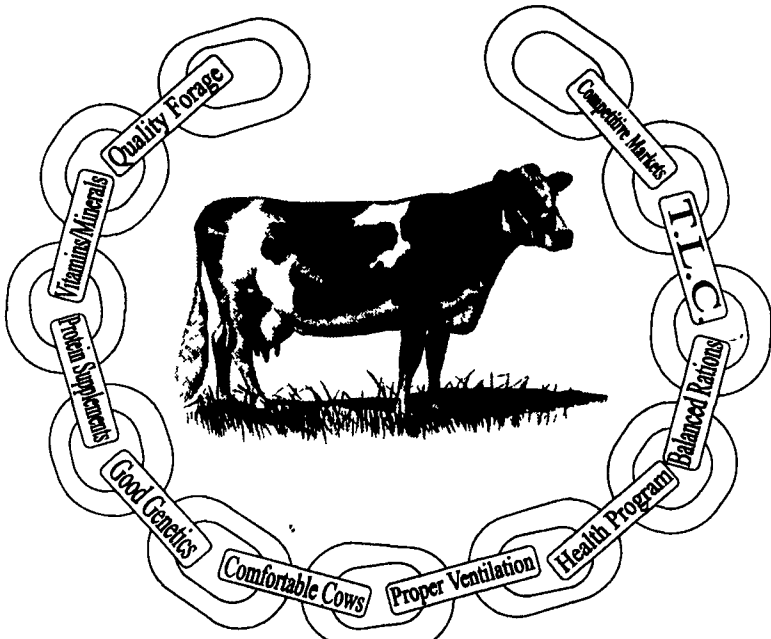

**CHECK WITH BINKLEY & HURST BROS. INC. FOR CURRENT PRICING. DUE TO MARKET STRATEGY & VOLUME SALES, KEENAN MIXERS ARE PRICED LOWER TODAY THAN FIVE YEARS AGO!**

### TRUCK MOUNT • STATIONARY • PULL TYPE

- Durable Construction for Long Mixer Life
  - Paddle Rotates 8-10 RPM for Light Tumbling Action
  - Proper Particle Size of Mix Insures Healthy Rumen - Less Sorting
- NET RESULT? MORE & BETTER PRODUCTION!**  
 Contact Jim Huber at Binkley & Hurst Bros. Inc.  
**1-800-414-4705 or 717-626-4705**

### SEE BINKLEY & HURST FOR A GOOD SELECTION OF USED TMR MIXERS

Good Clean Vandale  
**TMR 210 Mixer**  
 Feeder with Scales



210 Cu. Ft. (UM 4807)  
 Ask For Jim!  
**\$5,800**

Compact 70  
**Keenan TMR Mixer**



245 Cu. Ft.,  
 Approx. 4 Years Old

Monimixer  
**TMR Model 1460**  
 Trailer Type  
 460 Cu. Ft. Approx  
 2 Years - Call For  
 More Information!  
 Ask for Jim!

**Oswalt TMR**  
 400 Cu. Ft. Trailer Mixer  
 with Scales, New Augers  
 & Liner (UM 4906)  
**\$8,500**



### JAYLOR Model 2575 Trailer Model In Stock With Dual Wheels!

Large Scale Performance Performs large scale tasks at a small scale price. A minimum hp requirement of 90 and a maximum capacity of 575 cu ft., make the 2575 perfect for the growing herd size. The 2575 is a trailer model with aggressive mixing action. This almost new unit in stock - grind your big round bales (UM 4918)  
**Only \$27,500**

**BINKLEY & HURST BROS. INC.**  
 133 Rothsville Station Rd.  
 P.O. Box 0395  
 Lititz, PA 17543-0395  
 (717) 626-4705  
 1-800-414-4705  
 Fax 717-626-0996

## BINKLEY & HURST BROS. INC. HAS A GOOD SELECTION OF QUALITY PRE-OWNED!

<p>John Deere 210                  Disk Harrow</p>	<p>Deep Till Zone Builder                  Ripper with Coulters</p>
<p>12 Foot Cut with Packer                  Hitch &amp; Hoses                  (UM 4658)  <b>\$2,500</b></p>	<p>6 Shank on 30" Spacing                  with Optional Coulters to                  Cut the Residue, In Good                  Condition (NE 8663)                  Was \$7,950  <b>NOW \$6,990</b></p>

**Very Good Condition!**  
 Same As Case IH 8530 In-Line Square Baler  
 Hesston Model 4570 with Thrower  
 For After Sales Service,  
 Binkley & Hurst Is Your  
 Dealer! Ask About 5.4%  
 Financing For 36 Months!  
 Don't Miss This One If You  
 Are Looking For a Baler  
 With Very Little Use!  
 (UM 4789)  
**ONLY \$9,850**

**CASE IH 8330 9' Pull Type Mower Conditioner**  
 (We Sold New), Nice .....\$2,950  
**UM 4879 Pull Type Wing Fold MCKEE 36-TINE FIELD CULTIVATOR** 12' Center, 3' Wings, Good Frame, Good Shovels, Rolling Leveler Basket, Gauge Wheels on Center Section and Wings .....\$1,995  
**UM 4581 (2) GANDY INSECTICIDE ROW UNITS** w/Rubber Rotor (12 Volt) .....\$100 EA.

**BINKLEY & HURST BROS. INC.**  
 (717) 626-4705  
 133 Rothsville Station Rd.  
 P.O. Box 0395, Lititz, PA 17543-0395  
 Located 1/2 Mile North of Rothsville  
 1-800-414-4705  
 Fax 717-626-0996  
**CASE III**

**See Binkley & Hurst Bros. For a Little OR Big Heavy Duty KNIGHT Slinger Spreader In Stock!**

**300 BU. 8014**  
 Ideal For Top Dressing Grasslands

**800 Bu. Model 8040 OR 4060 Gallon Slinger**  
 With 23.1x26 Tires, Optional 28Lx26 Tires for Super Flotation, Haul Pen Packed or Slurry Manure Fast! See Us Today!

**Twin Auger**

Cut-away view showing Patented Material Flow

Forged steel Hammer  
 Each hammer has a nylon bushing and a replaceable manganese steel wear plate.

**Control Flow by Gate Opening Distance**

**Also, Pre-Owned Model 8018 & Model 8014 In Stock**  
 Ask for Amos Sr.

**BINKLEY & HURST BROS. INC.**  
 133 Rothsville Station Rd.  
 P.O. Box 0395, Lititz, PA 17543-0395  
 (717) 626-4705 1-800-414-4705 Fax (717) 626-0996