

USED TRACTORS

- IH 1066.....\$7,800
- IH 1066 Cab & Air, New Clutch & TA, Radial Tires 90%.....\$9,900
- IH 1066.....\$9,200
- IH 1066.....\$9,000
- IH 1066.....\$8,900
- IH 1466.....\$8,600

USED EQUIPMENT

- JD 3960 Harvester w/Table, Steel Wheels.....\$5,500
- NH LX665 Skid Loader, 2000 hrs.....\$13,900
- NH 40 Silage Blower, Nice.....\$1,875
- NH 456 Mower.....\$1,450

Liquid Manure Pit Pumps

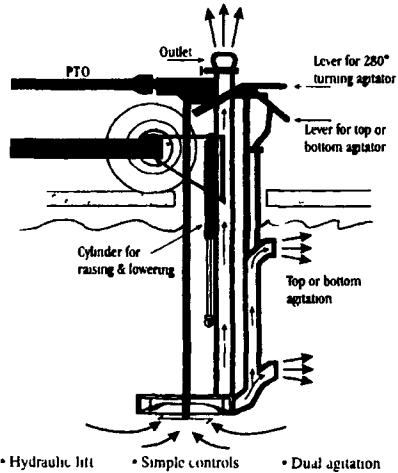

MILLER'S REPAIR
1 Mile North of Bird in Hand
8 Miles East of Lancaster
Ph. 717-656-6109

IH 3688 \$13,500



2500 hrs original, new rubber, very good tractor
301/334-8517

SPECIAL SALE • SPECIAL SALE

WISCONSIN HEAVY DUTY ENGINES REPLACEMENT ENGINES REPLACEMENT SHORT BLOCKS

WISCONSIN SURPLUS SPECIAL

MVH4D 30 HP Low Hours.....As Low As \$895

KOHLER SURPLUS SPECIAL

CH25S 25 HP, electric start.....As Low As \$1,190
CH18 18 HP, electric start.....As Low As \$895

HONDA SURPLUS SPECIAL

GX670 24 HP.....As Low As \$1,040
GX390 13 HP.....As Low As \$580
GX340 11 HP.....As Low As \$555
GX270 9 HP.....As Low As \$490
GX240 8 HP.....As Low As \$470
GX200 6.5 HP.....As Low As \$345
GX160 5.5 HP.....As Low As \$299
GX120 4 HP.....As Low As \$285
G100 2.5 HP.....As Low As \$239
GC160 5 HP.....As Low As \$210

FOR ALL YOUR ENGINE NEEDS CALL:

717-768-7669

3918 E Newport Rd
Gordonville, PA 17529

U.P.S. Daily
Pick-up & Delivery Available

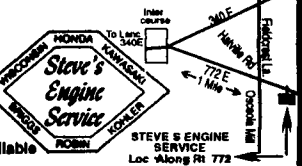

SPECIAL SALE • SPECIAL SALE

VALLEY AG & TURF

Halifax, PA 17032

Phone: 717-362-3132

1-800-362-3132



NEW EQUIPMENT IN STOCK

- MX 10 Rotary Cutter
- 1517 Wing Fold Rotary Cutter
- 9650 STS Combine
- MX7 Rotary Cutter
- 1750 6R Corn Planters
- 450 Drill

CLEARANCE SPECIALS

- JD 5410 4WD, Power Reverser 541 Loader 56 Hrs. Very Clean \$32,500
- JD 955 4WD, Turf Tires, 72" Mower, 70A Loader Coming In
- JD 640 Hay Rake \$1,900
- Bobcat 853 Skid Loader Coming In
- Case C50 W/Loader, 4WD, Shuttle Shift, Industrial Tires, 300 Hrs \$18,400
- JD 260 Skid Loader, 300 Hrs Coming In
- JD 4300 HST, 4WD, Industrial Tires, w/Loader, 330 Hrs \$15,900
- JD 425 54" Mower, 40 Loader 390 Hrs \$6,800
- Ferguson 30, New Rear Rubber, Good Condition \$2,675
- JD 8400 MFWD, Duals, 4SCV's \$85,000
- JD 3970 w/Hay PU **Reduced \$7,900**

GOOD USED TILLAGE EQUIPMENT

- JD 315 13' Disc \$4,000
- White 273 18 D sc \$4,500
- JD 335 21' Disc \$3,900

GOOD USED MOWER CONDITIONERS

- JD 1219 Mower Conditioner, Good Condition \$5,500
- Vicon Model KM321 Discbine \$4,400
- JD 930 MoCo \$11,700
- JD 1219 Mower Conditioner \$1,500

LAWN & GARDEN TRACTORS

- JD 325 48" Mower, Very Nice \$4,500
- 60" Mid Mount Mower for JD 650, 750 Tractor, Very Good Condition \$975
- Scag STH61 60" Mower, 600 hrs \$4,900
- JD 445, 54" Mower \$6,800

USED COMBINE HEADS

- JD 915 Flex Head.....\$5,800
- JD 444 Corn head, Lo Tin.....\$4,000
- JD 213 Flex Head.....\$3,500
- JD 213 Rigid Head.....\$2,800
- JD 444 Corn Head.....\$4,800

USED COMBINES

- JD 7720 Titan II, Straw Chopper, 4800 Hrs \$35,000
- JD 4400 Dsl, Rotary Screen, Header Height, 3400 Hrs \$5,500
- JD 9400 Combine w/Green Star Yield Monitor...\$58,000

SUMMER CLEARANCE SALE

- JD 750 15' Drill, Dolly Wheels \$14,400
- JD 709 Rotary Cutter, Pull type, Very Good Cond \$3,900
- JD 7200 Conservation 4R Corn Planter, Dry Fertilizer \$10,500
- JD 8300 21' Drill, 21x7-1/2' \$3,500
- Great Plains 24' Folding Drill \$6,500
- H&S Model 3302 600 Bu Spreader w/Lid \$13,900

Binkley & Hurst Bros. Inc.



ProTwin Features at a Box Spreader Price

Knight Hammer Design Impeller Shreds Manure For Even Distribution of Nutrients for Easier Incorporation Into Your Soil.



Get the soil nutrients needed to grow your corn crop this year. If you have pen pack, sticky feed lot or slurry-type material that needs to be spread fast and spread evenly, you need the **KNIGHT PRO-TWIN SLINGER. Name Your Size - From Little To Big!**

Low Clearance From Little to Big Heavy Duty Box Spreaders at Binkley & Hurst



BINKLEY & HURST BROS. INC.
133 Rothsville Station Rd.
P.O. Box 0395, Lititz, PA 17543-0395
(717) 626-4705 1-800-414-4705 Fax (717) 626-0996

NOW IS THE TIME... TO SERVICE YOUR PLANTER!

As the 2001 corn and bean planting season comes to a close, we encourage you to reflect momentarily on your spring planting experience. Does anything come to mind that may require attention before next planting season? Now is the time to deal with any potential problems or worn items before placing your planter in storage.

Contact the planter shop at Binkley & Hurst today to schedule your UPTIME PLANTER SERVICE!

Mr Planter Owner
Thank you for taking a minute to consider our services. Binkley & Hurst Bros Inc is offering a pre-season inspection and evaluation of your planter for the purpose of identifying worn, broken, or malfunctioning parts. Many times, seemingly insignificant wear will affect the accuracy of your planter more than you realize. If nothing else, it may be time to have your finger pickup meters checked on our test stand. Also, new innovations, attachments and options are constantly being introduced which may be of interest to you for installation on your planter.

Binkley & Hurst parts and service personnel are specifically trained and informed planter specialists, ready to examine your planter with you! If you determine that the planting proficiency of your planter could be improved with our service, we would be happy to provide that service for you, and a technician would return at a later date to assist you in doing the work. We encourage you to be part of the actual servicing so that any pointers or insight, which the technician may have for you with regard to planter operation, could be conveyed at that time.

If you set up an appointment for a planter evaluation, you will be charged a flat fee.

At time of inspection we will recommend to you any item needing attention, also at that time we will remove your seed meters to take in for testing if you so desire.

If you have any questions, please contact the planter service department at 717-626-4705 or 800-414-4705.

Thank you.
Kevin Smoker
Kevin Smoker

800-414-4705
717-626-4705
Fax: 717-626-0996



E-mail: info@binkleyhurst.com
Visit us: www.binkleyhurst.com

Your KINZE MFG.

Dealer With Hundreds of Planter Sales & Service Support Experience.

A "Hitch Pin to Closing Wheel" Evaluation of Your Planter
KINZE * DEERE * CASE IH * NEW IDEA PLANTERS

We've had growers tell us their planters perform as good as brand new after an uptime evaluation and service had been performed!

MISCELLANEOUS USED PLANTERS FOR CORN OR BEANS - GET ONE NOW!

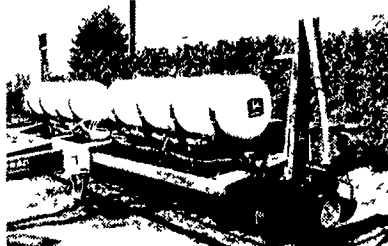

Kinze 2000
6x30 w/15" Push Units, No Fert., Insecticide (UM 4638)
\$10,500

(2) Gandy Insecticide Row Units
with Rubber Rotors and 12-Volt Electric (UM 4581)
Each \$100

JD 7000 Conservation Planter
8x30, Liq. Fert., No Til, Monitor, Markers, V.G Cond (UM 4348)
\$9,900

John Deere 7240 Bean Planter
11 Row 15" Spacing with 3 Bushel Hoppers, Liquid Fert., Monitor & radar, Markers and Lights (UM 4697)
Super Deal!

Almost New! Make Offer on this John Deere 7000 6-Row 30" Spacing Cons. Planter
with All New Kinze Frame-Mounted Coulters, New Double Disk Fert Openers, All New Row Units, Liquid Fertilizer, Insecticide, Markers & Monitor, Repainted and in Like-New Cond., Field Ready

Kinze 2500 Narrow Transport Swing Frame

New Idea/Kinze
7x18, Dry Fert., 4x36 w/18" Interplant Rear (UM 4623)
\$3,350

8x30 Liq Fert., Monitor, 15" Interplant Kit, Frame Coulters, Very Good (UM 4661)
CALL!



133 Rothsville Station Rd.
P.O. Box 0395
Lititz, PA 17543-0395
(717) 626-4705
1-800-414-4705

