



**Haulers Dream - Every Option Covered!**  
 1998 Ford F800 w/Cummins 210 HP 42" Sleeper Bunk, Straight 6 Speed Trans., Wide Load Signs and Mirrors, Aluminum Bed, With Fifth Wheel, Aluminum Rims, Only 39,000 Miles, Also Two Gooseneck Trailers, 47' and 26' One With Beaver Tail and Ramps, This Is A Honest, Solid Package, Priced To Sell. Will Separate.  
 Lanc. Co., Pa. **717-355-9262**

**1980 Mack 10 wheeler dump, 300, 10 speed w/1 way 11-1/2' snowblade.....\$11,500**  
**1979 Chevy C70 dump, 366, 5+2 speed, w/Myers 10' 2-way blade, tailgate salt cinder.....\$3,500**  
**Ford F350, 4x6, Boss V-plow, in-bed salt cinder....\$9,500**  
**Austin Western 6 wheel drive articulating grader, 11' 1-way blade on front, 11' wing plow, Detroit power.....\$11,500**  
**Fiat Allis 745B articulating loader.....\$13,500**  
**1980 Load King fold down detach trailer, double drop, 24' well.....\$7,500**

**81 Chevy Dump Truck**  
 33K GVW, Single Axle, 8.2 Detroit. Heads Done Over in 3/00. 5 & 2 Pinfile Hook w/Air. 12' Box w/Auto. Asphalt Tarp.  
**Asking \$13,500**  
**570-433-4518**  
 After 8 PM

**LEFEVER BROS. CHEVROLET CHEVY TRUCKS GEO.**  
**YOUR DIRECT LINE TO GENUINE GM PARTS**  
**(800) 533-3837**

When you call the number listed above, you'll reach our wholesale parts specialists, who can help you keep your GM repair work moving quickly  
 Ask about

- Specializing in GM Medium Duty Trucks, Current and Obsolete.
- \$500,000 Parts Inventory.
- Parts Locator for Those Hard to Find Items.
- We Ship Anywhere, Local Delivery Available.
- Experienced, Knowledgeable Personnel.

Mon Tues, Thurs, Fri 7:30 a.m. - 4:30 p.m.  
 Weds 7:30 a.m. - 8:30 p.m.  
 Major Credit Cards Accepted

**(717) 432-9697**  
 Quality Dealer Since 1921  
 406 U.S. Rt 15 Dillsburg, PA 17019

**GENUINE GM Parts** **Nothing's better than an original.**





**ALL STEEL REPLACEMENT TRUCK BED**



7'X70"W or 80"W  
 8 1/2' Lx82"W or 96"W  
 10'Lx8"W, 12'Lx8"W

STARTING AT \$595.00

8'x10' \$995



UTILITY (TILT OR GATE MODEL) SIZES:  
 4'x8', 5'x8', 5'x10' 2000# GVW - 5'x10'  
 6'5" x12', 3000# GVW

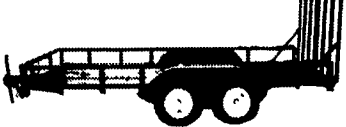

UTILITY WITH GATE-SIZES:  
 16'x77", 18'x77", 7,000# GVW

**ALSO 84" WIDE!**



CAR HAULER TRAILER:  
 16'x78" & 18'x78" includes 5' Beaver tail  
 7,000 lb. GVW 4' self storing ramps

**Quality Trailers Built Locally By "PA International"**

**Car Dollie**



Sale \$795

**19 Ft. Hydraulic Tilt Trailer, 10,000 lb. GVW \$3,395**

**3 Pt. Finish Mowers 5' - 6' - 7'**

**3 Pt. Rotary Mowers 5' - 6' - 7'**  
 Reg. - Med. - Heavy Duty

**Over 200 Trailers IN STOCK**  
**Starting At \$475.00**  
**T-Plates DEALERS WANTED**

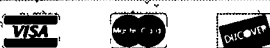

**Highway Hydraulic Dump BRI-MAR**



5'x8', 3000# \$2,195  
 5'x8', 5000# \$2,495  
 6'x10', 7,000# \$3,195  
 6'x10', 10,000# \$3,495  
 7'x12', 10,000# \$3,995

**FREE BATTERY**

**LOW PROFILE DUMP TRAILERS BRI-MAR**



6 x 12 10,000# low profile \$4,095  
 6'x10' GVW low profile dump trailers w/ landscape gate  
 7,000# \$3,495  
 10,000# \$3,795

**FREE BATTERY**

Starting At \$3995 w/4' Adj. Tail



GOOSENECK SIZES: 20'x8' 12,000# or 14,000# GVW, 24'x8' 14,000# GVW

Low Profile construction 16'x77" & 18'x77" 10,000 # GVW



DECK-OVER CONSTRUCTION  
 20'x8' w/Tail 10,000# GVW \$3,295  
 20'x8' w/Tail 12,000# GVW \$3,695

**KUTZ FARM EQUIPMENT, INC.**  
 Pine Grove, PA 570-345-4882 FAX 570-345-2884  
 8 AM-5 PM Monday Thru Friday  
 8 AM-12 Saturday Or By Appointment

**ALL STAR Mack New & Used Trucks**



**1985 MACK R685ST**  
 E6-275, Mack 5-Spd., FAW 12, SS-38, Steel Disc, 11R22.5, 13'6" Steel Body, In Chassis Overhaul 6 Months Ago



**1997 CH613**  
 E7-350, T2090, Air-Ride, 4.17R, ST-Disc Wheels, 295/75R22.5, Mileage 120,650, Clean Truck Also 1-1995 Day Cab



**2000 MACK MS250P**  
 Chassis, E3-190, 4106A-6 Spd., 12 Front, 21 Rear Axle, 217 W.B.



**1996 MACK CH613**  
 E7-350, RTX14609 B Trans., DS 404 Eaton, B Trans., AL401 Air Ride Suspension, 4:11 Ratio, 204" WB, 42" Sleeper



**20-1995 Mack E7-350 RTLO14610B**  
 10 Spds., DS404 - 3.9OR on Air, Steel Disc Hub Pilot, 295/75R 22.5 192 WB, 42" Highrise, 440,000 Miles

Includes 200,000 Mile Engine Warranty, All Trucks Have Been Run on Dyno.

**TRUCK TECHNICIANS NEEDED**  
 Come Join a Leader in the Trucking Industry. Contact: Gary or Tod

**LESHER Mack SALES & SERVICE**  
 2700 Cumberland Sts. Lebanon, Pa. 17042 (Route 422 West)  
 website: www.leshermacksales.com **717-273-4535**

**CHEVROLET GMC**

**Sutliff GM PARTS**  
 GENUINE GM PARTS FOR ALL GM VEHICLES  
**800-932-0284**

**Free Delivery Routes In 12 Counties In Central PA**  
**Call For Specifics**

**25 PARTS PROFESSIONALS TO SERVE YOU**  
**ENGINES - TRANSMISSIONS**  
**A.C. DELCO - SHEET METAL**  
**ALL IN STOCK AND PRICED RIGHT**  
**IF YOU NEED GM PARTS**  
**WE'VE GOT WHAT YOU NEED**

**SUTLIFF GM PARTS**  
 13th & Paxton  
 Harrisburg, PA



We Want Your Business

**A GM Goodwrench Service Plus Dealer**  
**The Plus means better.**  
**CHEVY TRUCK**

**OLDS** **CADILLAC** **PONTIAC** **BUICK**