

dhia

Scott Williams
Training Coordinator

Call 1-800-DHI-TEST, fax (814) 865-3294
Web site <http://www.dhia.psu.edu>
Pennsylvania Dairy Herd Improvement Association
DHIA Service Center, Orchard Road, University Park, PA 16802

PA DHIA Herd Management Workshops, District Meetings

Dave Slusser
General Manager
STATE COLLEGE (Centre Co.)—DHIA has set the dates and locations of nine district herd management workshops and district membership meetings. All members, interested farmers, and industry representatives are invited. This interesting and educational workshop will include presentations by George Cudoc on "How Cows

Talk to Us and What They Say," and a live demonstration of *Barn Owl 2000* herd management software. During the workshop, members and guests will be provided a lunch, and following the workshop, members will conduct the district membership meeting.

PA DHIA provides a very valuable service that will positively impact your bottom line. Our herd management reports,

and our *Barn Owl 2000* software provide excellent analytical tools for you, your herd consultant, nutritionist, and veterinarian. You will improve your production efficiency if you and your advisors use the DHIA information. Come and bring your advisors to learn how to better use this valuable information. The program and meal are free. You have nothing to lose and everything to gain.

During the brief membership meeting, members will elect their directors to the board where terms have expired and will discuss a proposal by the board planning committee to nominate and elect directors by mail ballot. The board feels that the membership will be better represented by the mail ballot system, however, that will require a by-law change. The board hopes to get ideas from the members at these workshops and meetings.

Listed below are the dates and locations. Please mark your calendar and attend. Notices of these workshops and membership meetings will be in your herd report envelopes and in PA DHIA ads. All meetings begin at

10:00 a.m. Elections will be held in Districts 3, 6 & 9.

District 11

February 4

Mt. View Restaurant, Clifford

District 9

February 7

Blue Mt. Restaurant, Shartlesville

District 10

February 8

Gap Diner, Gap

District 6

February 9

Lighthouse Restaurant, Chambersburg

District 5

February 10

Family Restaurant, Mifflintown

District 1

February 11

Bonanza, Franklin

District 8

February 15

Iron Skillet Restaurant, Milton

District 7

February 16

Edgewood Family Restaurant, Troy

District 3

February 18

St. Mary's Country Club, St. Marys
District 2 & 4

March 9

(to be held in conjunction with the Southwest Dairy Seminar)

Average Farm Feed Costs for Handy Reference

To help farmers across the state to have handy reference of commodity input costs in their feeding operations for DHIA record sheets or to develop livestock feed cost data, here's last week's average costs of various ingredients as compiled from regional reports across the state of Pennsylvania.

Remember, these are averages, so you will need to adjust your figures up or down according to your location and the quality of your crop.

Corn, No.2y — 2.37 bu., 4.24 cwt.
Wheat, No.2 — 2.38 bu., 3.98 cwt.
Barley, No.3 — 1.62 bu., 3.47 cwt.
Oats, No.2 — 1.51 bu., 4.71 cwt.
Soybeans, No.1 — 4.41 bu., 7.37 cwt.
Ear Corn — 75.55 ton, 3.78 cwt.
Alfalfa Hay — 134.25 ton, 6.71 cwt.
Mixed Hay — 138.75 ton, 6.94 cwt.
Timothy Hay — 135.00 ton, 6.75 cwt.

Extension Sets Meeting

In February, Penn State Cooperative Extension will be presenting an Agricultural Small Business Institute in Adams and Lancaster counties. Each week includes lunch (Lancaster) or dinner (Biglerville). Spend a few hours learning how to improve your business while visiting and interacting with other agricultural business owners from around your area. The program is open to owners of all agricultural businesses.

The topics and speakers will be: "Leading Your Business and Evaluating the 'Sweet 16'" — the speaker will be Gary Snider from Farm Credit; "Business Plans" — the speaker will be G. Geoffrey Sturgill Jr., CPA; "Enterprise Accounting" will be presented by Bradley J. Hilty from PLS Agri-Management Associates. The last week will be "Managing Employee's for Peak Performance" presented by Dr. Bernie Erven from Ohio State University.

The dates for Adams County will be February 2, 9, 16, and 23. The meetings will be held at the Penn State Fruit Research and Extension Center, University Drive off of Rt. 234. Call the Adams County Extension Office at 334-6271 or 624-4525 for further information or directions.

The dates for Lancaster County will be February 3, 10, 17, and 24. The meetings will be held at the Kreider Farm Restaurant, Rt. 72 south of Manheim. Call the Lancaster County Extension Office at 394-6851 for further information or directions.

The fee for this program is \$50 per person, which includes all materials.

Attention Dairymen!

- ★ Reduce SCC
- ★ Improve milk quality
- ★ Increase profits & bonuses
- ★ Keep lines clean
- ★ Reduce cleaning compounds

Millers Water Works
1-800-991-9188

WANTED

Hog Fattening Facilities

Groups of 300 Head or Less
Within 25 mile Radius of Lebanon
(717) 272-9531

HOULE

LIQUID MANURE SPREADER

WITH FLOTATION TIRES TO MINIMIZE SOIL COMPACTION

Available with complete line of spreading tool bars and precise flow control to spread manure the ecological way eliminating spray drift and reducing odors. Our tool bars are designed to apply hog or dairy manure on growing fields, between rows of corn or on harvested fields.

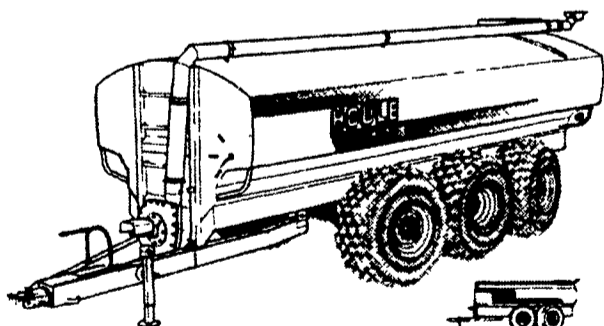

4-6 OR 8 WHEEL SPREADERS WITH POWER STEERING 3850 TO 9500 US GAL.

SPREADERS WITH SINGLE AXLE OR TANDEM-2350 TO 6000 US GAL.

- "V" shape bottom for more complete clean out.
- Standard exterior finish: epoxy primer and urethane paint.
- Low profile tank for maximum visibility and stability.

TRAIL AGI-POMPE

32' and 42' for Lagoons

GREAT PERFORMANCE IN HOG OR DAIRY MANURE

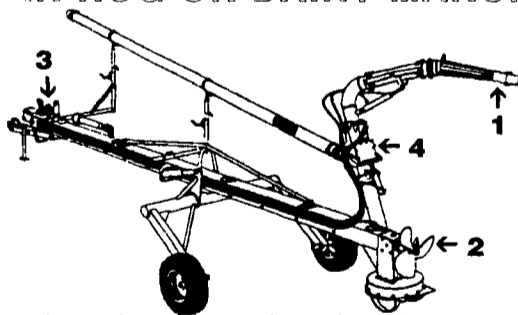

1-Highly articulated nozzle designed to slice and break the top crust from above the manure level as the propeller homogenises the liquid with the remaining floating chunks.
3-Hydraulic controls can be operated from tractor seat.

2-24" dia. mixing propeller providing full time agitation up to 21,500 US G.P.M. even when loading a spreader.
4-Rotative directional valve designed to be operated at low R.P.M. without stopping the P.T.O.

Gear box oil bath protected by a greasable 3 seals mechanism on each shaft.

AVAILABLE WITH MULTIPURPOSE OPTION TO ALSO CLIMB INTO CONCRETE PITS UP TO 14' DEEP.

UNITS IN STOCK FOR SALE OR RENT

• 1999 Houle 3850 Tank Spreader
28Lx26 Tires

• 1999 Houle 32 Ft. Lagoon Pump

Cedar Crest Equipment



339 King Street
Myerstown, PA 17067
(717) 866-1888 • 1-800-646-6601

Parts Outlet
RD 2 Box 271
East Earl, PA 17519
(717) 354-0584

GOOD USED MIXERS FOR SALE

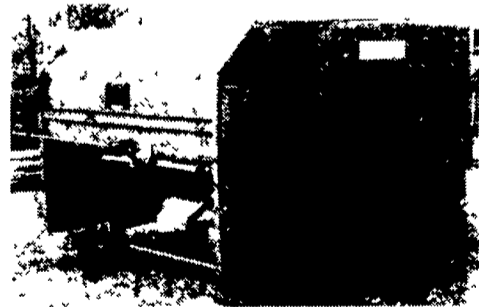

- Rissler 135 Mixer w/Electronic Scale, Excellent Shape
- Oswalt 230 Trailer Mixer in working condition

Also:

- Big Jim 20' Dia. Silo Unloader (Old Style)
- 24 Ft. Big Jim Unloader
- 25 Ft. Big Jim B.U.C.S. System
- V1-12 ft. Unloader complete w/Hexapod Hoist
- Jamesway 16 ft. Volumaster, Complete - Excellent Condition
- Silo-Matic 20 ft. Ring Drive

All In Good Condition

★ **STAR SILO** ★

Myerstown, PA

800-431-7709