

# Price-Sensitive Corn Growers to Pursue Grassroots Trade Campaign

DENVER, Colo. — The National Corn Growers Association (NCGA) met here last week to discuss four serious "can'ts" confronting corn growers preparing for this fall's harvest: can't sell, can't export, can't ship, and can't

store.

Corn Growers nationwide are deeply concerned about near record-low corn prices, drops in world demand for U.S. corn, high carry over stocks, and worrisome forecasts that critical rail transportation will be unable to meet harvest shipping demands.

NCGA's Corn Congress met Aug. 27-28 to determine immediate action growers nationwide should take to deliver a strong and clear message regarding global competitiveness and trade concerns which impact grower profitability to political leaders in Washington.

NCGA will coordinate a comprehensive grassroots campaign to address these critical shortfalls. "NCGA's strategy is to call for important legislative and policy solutions that can remedy current low price concerns," said NCGA President Ryland Utlaut from Grand Pass, Mo.

Trade policy, according to Utlaut, is a top priority that Washington must address immediately if farmers are to survive globally. "Since last fall, corn exports for the 1997 crop have fallen 550 million bushels, which significantly was also when Congress failed to pass fast track authorization for the next



## CORN TALK NEWS

PENNSYLVANIA MASTER CORN GROWERS ASSOC., INC.

President to negotiate new, better agreements," noted Utlaut.

Without fast track authority, most nations will not negotiate with the United States for fear they will then have to go back and renegotiate with the entire Congress. "I don't blame them. The fact of the matter is that our bread and butter is linked to international trade," Utlaut said, "If we are locked out of foreign markets, or if international monetary conditions

keep our product uncompetitive, then corn growers are left twisting in the wind."

NCGA's immediate priority is to influence Congress and responsible government agencies to pursue sound and strong trade policy objectives, which include:

- Passage of fast track and International Monetary Fund (IMF) support which are both scheduled for deliberation in late September.

- Meaningful trade sanctions reform, streamlining biotech trade approval policies, World Trade Organization (WTO) negotiations, Foreign Market Development (FMD) and Market Access Program (MAP) funding.

- Equally sound and strong domestic solutions like crop insurance reform, flexible loan policy and Loan Deficiency Payments (LDPS) to provide more timely relief.

- In the area of grain transportation, NCGA is calling for enactment of a Federal Emergency Preparedness Plan, emergency repeal of the Jones Act, passage of the Water Resources Development Act (WRDA), and close monitoring of the nation's railroads to ensure adequate service.

"This ambitious plan takes advantage of our proven grass-roots capability, but we can't do it alone," said Utlaut. "The outcome great of these workshops. Upon completion, it will become a "living" document, that can change and grow as new discoveries and research breakthroughs are made.

The final step will be the actual research and business development efforts that will make renewable technologies and products a reality.

For more information on the Renewable Vision or a copy 2020 or a copy of the "Plant/Crop-Based Renewable Resources 2020" document, contract the NCGA at (314) 275-9915 or visit its web site at <http://www.ncga.com>



# J-STAR

## YOUR ALL-IN-ONE FARMSTEAD EQUIPMENT

Silo Unloader Technology Takes a Giant Leap Forward!

### BIG JIM. Quantum SYSTEM

#### SIMPLY THE BEST!

You know tower silos are the best way to store feed. Now Jamesway® gives you the best way to fill and feed fast, with great reliability. Plus, you get:

- Better Feed Quality
- More Feed Storage
- A Clean Chute

The all-new industrial-design Big Jim QUANTUM System can be installed in any type of 20' to 30' forage silo. . . conventional or oxygen limited. And since it requires little maintenance and has no doors to change, you eliminate trips up and down the silo.



CALL US TODAY FOR A VIDEO AND BROCHURE.

The Silo Unloader Experts



LEASE IT TODAY WITH

## America's

### MAGNUM II™ SURFACE DRIVE SILO UNLOADER

America's best selling silo unloader just got better! Van Dale's been writing the book on silo unloading technology for more than 45 years. And Van Dale invented and perfected the surface drive unloader. Now it's time to introduce the next generation. The MAGNUM II!

The new MAGNUM II features a brand new Hi-Perform™ Impeller which adds more "throw-power" than ever before. Check it out and then check in with your Van Dale Dealer.

#### CHECK OUT THESE FEATURES

- ✓ Full 1/4" stainless steel back wrapper
- ✓ Formed 10-gauge stainless steel discharge area
- ✓ Adjustable 1/4" abrasion resistant cut-off plate
- ✓ Easy-access inspection cover
- ✓ 27" impeller

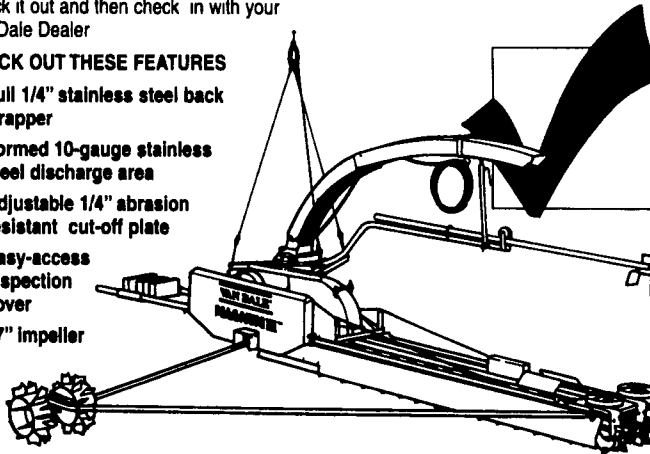
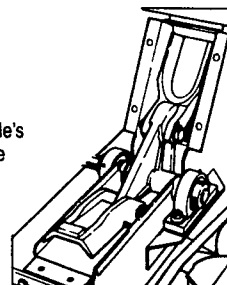

# THE VAN DALE ADVANTAGE

VAN DALE Dependability through Quality

• CABLE ALLEY SCRAPER

• WASTE HANDLING EQUIPMENT DUMPS - TANKS - TILLAGE APPLICATOR

• FEED HANDLES BELTS - FEEDERS - CONVEYORS

### See These Dealers For Details Now...

FRANKLIN'S FARM SERVICE  
Laceyville, PA 717-869-2407

HARRY TROOP  
Cochranville, PA 19335  
215-693-8731

HISTAND'S FARM & HOME SERVICE  
Rome, PA 717-744-2371

HOOVER EQUIPMENT  
Tyrona, PA 16686  
814-684-1777

JAMES L. HOSTETTER  
McVeytown, PA 17051  
717-899-8386

LAPP'S BARN EQUIPMENT SALES & SERVICE  
Gap, PA 17527  
717-442-8134

MARTIN EQUIPMENT  
Chambersburg, PA  
717-263-3505

McMILLEN BROTHERS  
Loysville, PA  
717-789-3961  
(VanDale Dealer)

MILL CREEK FENCE & FARM  
Lancaster, PA  
717-396-8987

PRINGLES SUPPLY & EQUIPMENT INC.  
Greenville, PA 16125  
412-688-7950

ROVENDALE AG & BARN EQUIPMENT  
Watsonstown, PA 17777  
717-538-9564  
OR 717-742-4226

SOLLENBERGER SILOS CORP.  
Chambersburg, PA 17201  
717-264-9588

SOMERSET BARN EQUIPMENT  
Somerset, PA 15501  
814-445-5555

STAR SILOS  
Myerstown, PA 17067  
717-866-5708

WALNUT BARN EQUIPMENT  
Port Royal, PA  
717-436-9429

MARYLAND GLADHILL TRACTOR MART  
Frederick, MD 21701  
301-663-8080

MD & VA MILK PRODUCERS ASSOC.  
Frederick, MD 21701  
301-663-8552

NEW JERSEY GEORGE COLEMAN  
Elmer, NJ 08318  
609-358-8528