

THE LUCKNOW MIXER WAGON

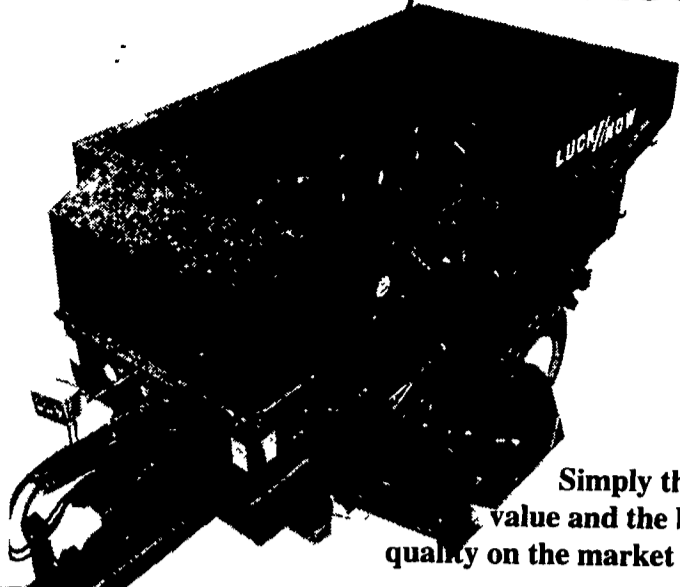

Simply the best value and the best in quality on the market today.

Call M.M. Weaver & Son
Leola, PA • (717) 656-2321

Complete 3pt Hitch, fits IH544 to 686.....	\$450
IH 454 Diesel w/Loader.....	\$7,200
IH 350 Utility w/PS, Very Nice.....	\$4,000
IH 424 w/Loader, Very Good Condition.....	\$6,200
IH 986, Cab & Air, 477 Original Hours, Showroom New.....	\$26,000

Financing Available
717-776-5515
JEFF SHOWAKER

Clean off-the-farm, field test tractors
Most Reconditioned And Sold With Warranty
Positively no out-of-state Personal checks



John Bean High Pressure Pump, 70 g.p.m. \$500
Also Myers 35 g.p.m. \$200 Myers 20 g.p.m. \$100

Brewer Equipment

Orangeville, PA 17859 • 717-683-5411

Well Built™ to Handle Your Hay

Trust Your Most Important Forage Crop to Stoltzfus Mfg.

Well Built™
Round Bale Carriers

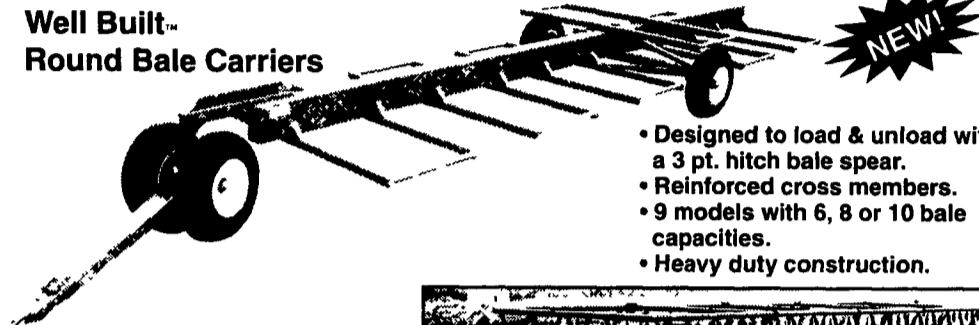

- Designed to load & unload with a 3 pt. hitch bale spear.
- Reinforced cross members.
- 9 models with 6, 8 or 10 bale capacities.
- Heavy duty construction.

Well Built™ Feeders:

- Built tough for long life!
- Available in a variety of lengths.
- Adjustable slant bar or self-locking head locks.
- Ideal for cattle in either feedlots or meadows.

Shown Well Built™ Slant Bar Feeder



Gates • Slant bar Sections • Head locks • Gutter grates

STOLTZFUS MFG

For a free brochure or more information call 610/273-3603

540 White School Rd
Honey Brook, PA 19344
610/273-3603

156 Pompey Hill Rd
Stoystown, PA 15563
814/893-5086

DEALER INQUIRIES INVITED • CUSTOM WAGONS A SPECIALTY

Fetor Fetor Fetor

COMPARE VALUE & PRICE

New **Fetor** Tractors - 2 yr. Warranty



IN STOCK

6340.0 Open Station
4WD, 10-Speed, 70HP
w/canopy

6340.2 w/cab, 4WD, 10-Speed,
70 HP, Shuttle Trans.

6340.2 w/cab, 4WD, 10-Speed,
70 HP, Shuttle Trans..
Front & Rear PTO & 3pt Hitch

DEMOS GIVEN

Fetor Fetor Fetor

KERMIT K. KISTLER, INC.

New & Used Farm, Lawn & Garden Equipment
Since 1947
Rt. 143 LYNNPORT, PA 18066
610-298-2011
Hours: 8-5, Sat. 8-2
Sales & Service
Pick-up & Delivery

Pump and Blast!

SERIES 5000 LAGOON PUMPS

Here's the answer to breaking up the thickest crusted pits or lagoons. The new Series 5000 Lagoon Pumps from Van Dale have the most impressive performance of any pump in their league. You want speed in agitation? The 5000's got it with up to 5,000 GPM power that will blast a stream of manure up to 100' or more! You want real pumping power? The 5000's got it. But that's not all.

Van Dale's Series 5000 has three models to match your individual manure handling needs in everything from shallow, straight wall pits to the deepest sloped wall lagoons. See your Van Dale Dealer now and get a Series 5000 working to save you time, labor and money.

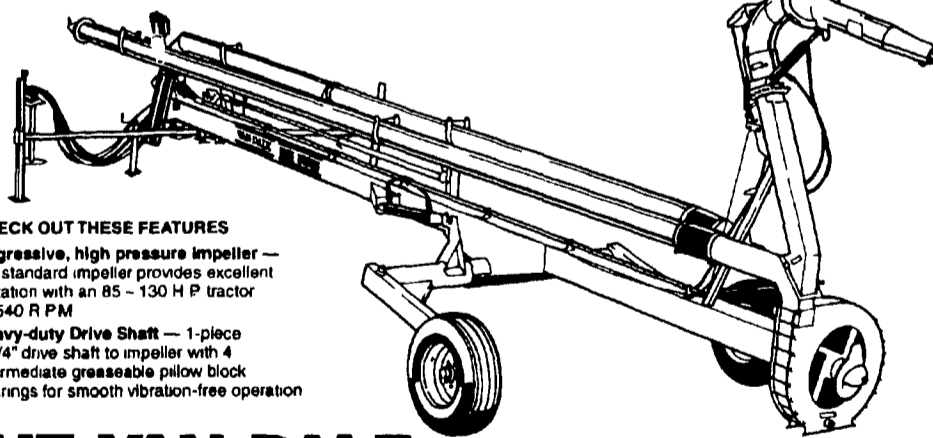

CHECK OUT THESE FEATURES

- ✓ Aggressive, high pressure impeller — 28" standard impeller provides excellent agitation with an 85 - 130 HP tractor @ 540 R.P.M.
- ✓ Heavy-duty Drive Shaft — 1-piece 1-3/4" drive shaft to impeller with 4 intermediate greaseable pillow block bearings for smooth vibration-free operation

THE VAN DALE ADVANTAGE

Contact your local dealer for details!

VAN DALE

WASTE HANDLERS

- ✓ Hydraulic Controls — trailer, horizontal and vertical movement and agitate/fill valve are easily operated from the tractor
- ✓ Adjustable Nozzle — Unique 120° vertical and 340° horizontal movement directs manure blast with precise control
- ✓ 32' and 42' Trailer Models — 68" ground clearance for easy transport around lagoon
- ✓ Maneuverable 16' 3-Point Hitch Model — Designed for use in 6 - 14' deep straight and sloped wall open pits



LAPP'S BARN EQUIPMENT, INC.

5935 OLD PHILADELPHIA PIKE, GAP, PA 17527
PHONE: 717-442-8134 • FAX 717-442-3112

SALES & SERVICE

Call or write for free catalog.

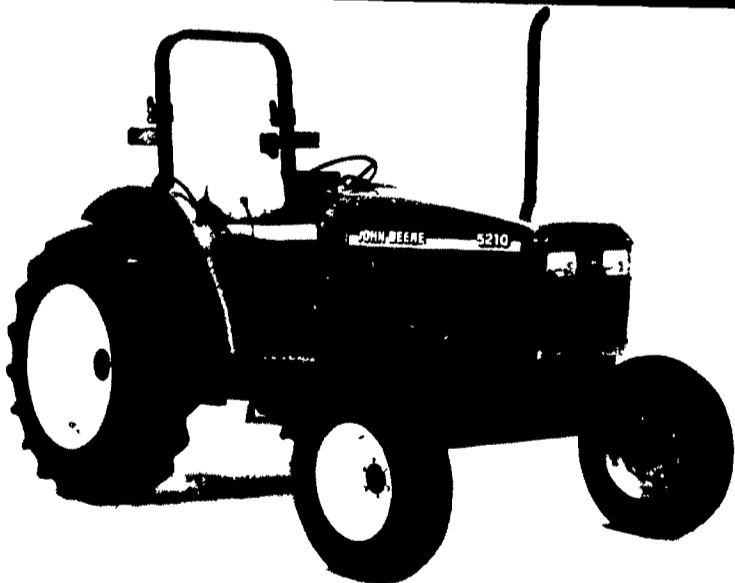

New 5210 Tractor. Take it easy.

Here's your solution to tough jobs. The new 45-PTO-hp John Deere 5210. Its improved cleaner-burning diesel engine kicks out more torque. Tough jobs just got easier. The new 5210 is also quieter and easier to operate. You can even add an optional cab and four-wheel drive. So why not take it easy? Stop by and check out the new 45-PTO-hp 5210 Tractor and its capacity-matched John Deere attachments. With the 5210 you can tackle tough jobs, easily.



—Model 5210 Tractor IN STOCK—
Nothing Runs Like A Deere

KERMIT K. KISTLER, INC.

New & Used Farm, Lawn & Garden Equipment
Since 1947
Rt. 143 LYNNPORT, PA 18066
610-298-2011
Hours: 8-5, Sat. 8-2
Sales & Service
Pick-up & Delivery