

THE UNLOADER FOR HIGH MOISTURE GRAINS

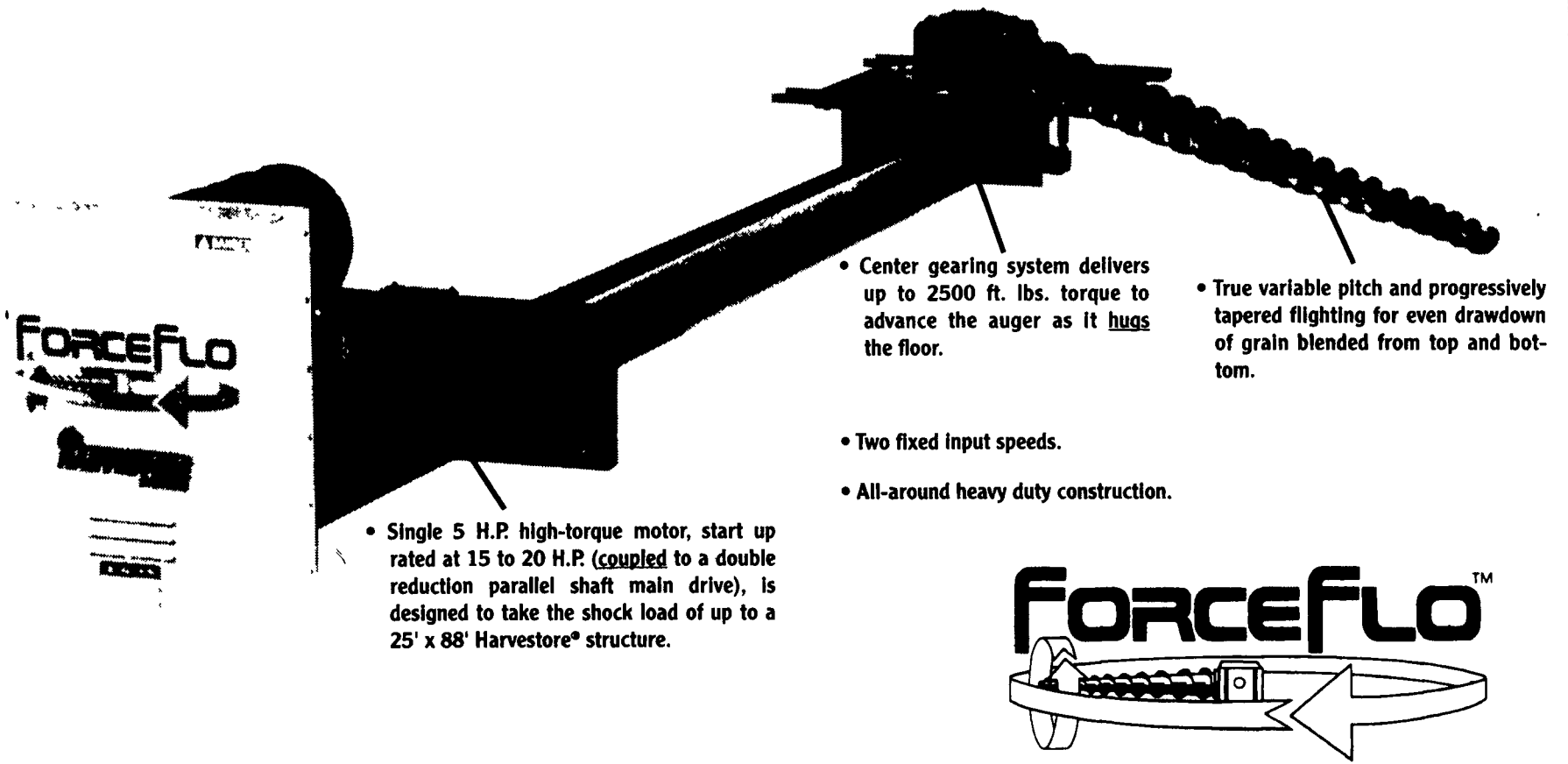

- Center gearing system delivers up to 2500 ft. lbs. torque to advance the auger as it hugs the floor.
- True variable pitch and progressively tapered flighting for even drawdown of grain blended from top and bottom.
- Two fixed input speeds.
- All-around heavy duty construction.
- Single 5 H.P. high-torque motor, start up rated at 15 to 20 H.P. (coupled to a double reduction parallel shaft main drive), is designed to take the shock load of up to a 25' x 88' Harvestore® structure.

THE SOLIDS SEPARATOR

(Our secret... simplicity!)

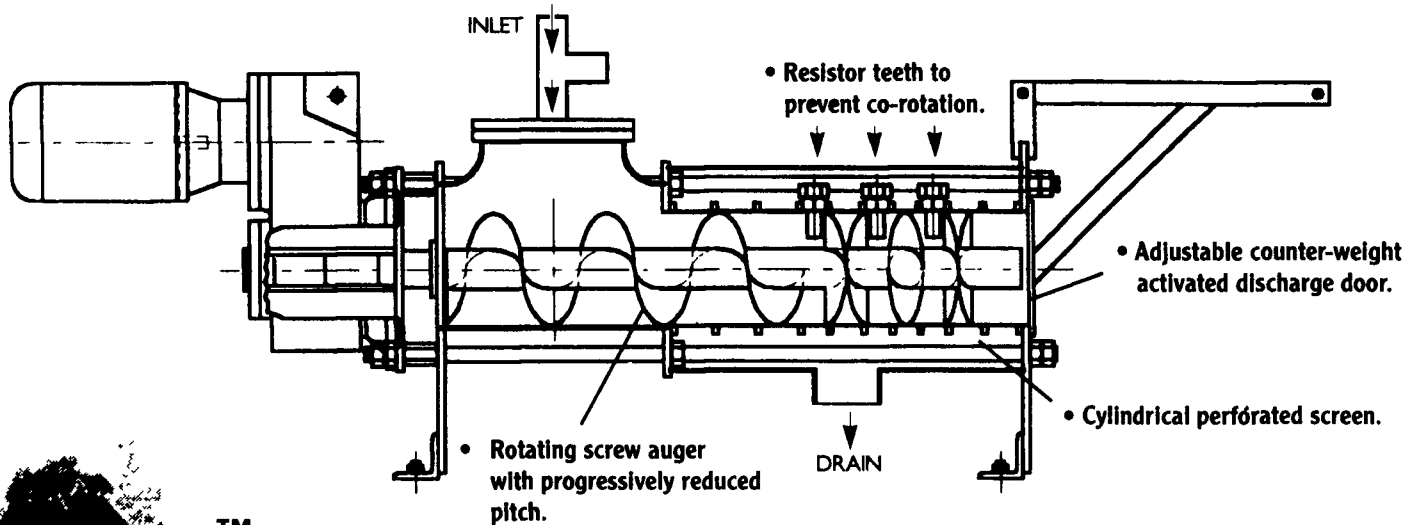

**Sierra™
KP-10**

For your convenience now accepting



PENN JERSEY PRODUCTS, INC.

YOUR LOCAL INDEPENDENT AUTHORIZED HARVESTORE® SYSTEMS DEALER
P.O. BOX 7 • NEW HOLLAND, PA 17557 • 717-354-4051

Bellefonte, PA
800-310-9333
Rory Peachey, Mgr.

Everett, PA
814-652-2934
Frank Samuel, Jr., Mgr.

Berlin, PA
800-434-3308
Joe Simpson, Mgr.

Newville, PA
717-776-3397
Maynard McCullough, Mgr.

Columbus, NJ
609-298-7136
Charles Van Mater, Mgr.

In Maryland
800-354-4052