

## USED COMBINE PARTS

**50% off or more.**

Many new parts available

Call for pricing

800/255-1071

**Bryant Combine Parts**

US 27, Bryant, IN 47326



Fax 219/997-6881



### USED TRACTORS

- IH 1086, 1980 Model.....\$15,500
- IH 1466.....\$9,000
- Cab For IH1066, A/C, White.....\$900
- IH 826 Cab, Nice!.....\$8,750

### USED EQUIPMENT

- Gehl 1540 Silage Blower.....\$1,450
- New Idea 206 Manure Spreader.....\$1,500
- NH 892 Harvester.....\$4,500
- Gehl 860 Harvester, nice.....\$3,200
- Gehl HA1110 grass head, like new.....\$2,220
- Gehl TR30-38 2R corn head.....\$1,400
- NH 565 Baler (like new).....\$7,800
- New Idea 323 Corn Picker (like new).....\$3,000

### Liquid Manure Pit Pumps

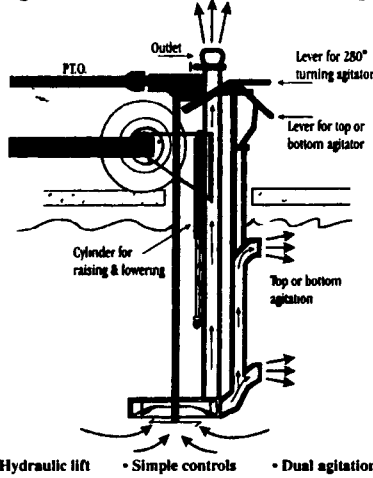

- Hydraulic lift
- Simple controls
- Dual agitation



**MILLER'S REPAIR**  
1 Mile North of Bird in Hand  
8 Miles East of Lancaster  
Ph. 717-656-6109

### "No-Jumpin"



Farmers! Check out this new hitch pin Fast, Easy, Secure!  
7/8" diameter  
\$12.00 each  
+ \$3.99 UPS  
3 for \$35 Free UPS

**Weaver Distributing**  
1-800-Weaver-D



**JD 7720 Titan II Combine**  
w/216 Flex Head  
Excellent Condition

**\$20,000 O.B.O.**

**717-242-3712**

### FILL-RITE PUMP SPECIAL

**FR-610**  
110 Volt  
**\$230.00**

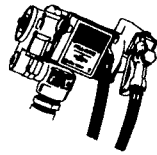

**FR-700**  
115 Volt  
**\$315.00**

### CERTIFIED PETROLEUM TECHNOLOGIES, INC.

75 South 13th Ave., Lebanon, PA 17042  
(717) 270-8910

Distributor of Fillrite Pumps

## Go Places That ONLY RAMROD MINI-SKIDS Can!



Mini Skids deliver big performance in small places. Machines are driver-friendly, with an un-obstructed view of all working conditions. Machines are easily transported in a trailer or pick-up truck. Ramrods have a wide variety of available attachments. These are just a few: •Pallet Fork •Post-Hole Digger •Backhoe •Trencher •Sweeper •Snow Blower •Breaker



110 South Railroad Ave.  
New Holland, PA 17557  
(717) 354-4191

Monday Thru  
Friday  
7:30-5:00  
Saturday  
7-Noon

# NICARRY TRACTOR

PO Box 399 Rt. 22 West, Fredericksburg, PA 17026  
Hours: Mon.-Fri. 8-5; Sat. 8-12; Closed Sundays

**717-865-7575**

Fax 717-865-7676

Specializing in Quality Used Compacts

## SALES-RENTALS

We Are 1/2 Hour From Harrisburg / 1/2 Hour From Reading  
45 Min. From Allentown



Kubota B1750 4x4, w/loader, ag tires, 350 hrs. \$10,900

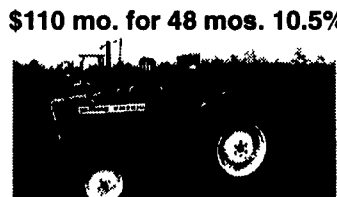

Yanmar 2610, 2WD w/Tiller, Low Hours \$5,500



Good Selection of 3 pt. Backhoes

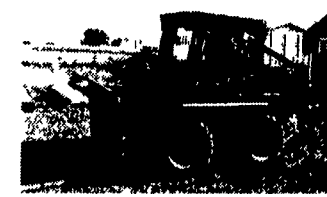

NH Lx565 Skid Loader Low Hrs., Excellent Cond.



Farmall H, Nice Condition \$1500



Kubota L2250 4x4 w/Loader, Shuttle Shift, 1900 Hrs. \$9,500

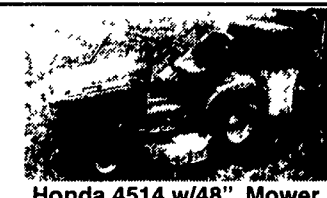

Honda 4514 w/48" Mower, Rear Bagger & Front Blade \$1,800

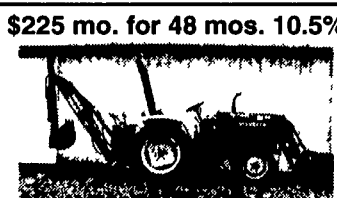

Ford 1710 TLB 4x4, 1500 Hours \$12,900



Kubota B7100 4x4, 1,700 Hrs., Ex. Cond. \$4,000



10 & 12 Ft. 5-Ton Dump Trailer



Kubota B8200 4x4 w/Loader & 60" Belly Mower



Starting At \$1,500  
Large Inventory of Trailers Pequea 1018 18 ft. Deck Overs Livestock Trailers, Dump Trailers



Kubota B7100 Hydro w/Belly Mower



Kubota F2400 4x4 w/60" Front Mower & Vac System

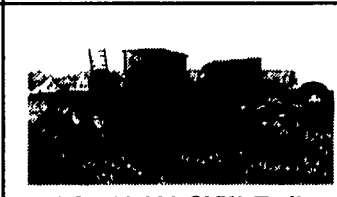

18 ft., 10,000 GVW Trailer w/Beaver Tail & Ladder Ramps

\* All Financing with approved credit and 25% down



108 Years Serving All Your Equipment Needs



110 South Railroad Ave • New Holland, PA 17557 • Telephone (717) 354-4191  
FAX (717) 355-2272 Call Toll Free 1-800-346-8319



**John Deere FORAGE HARVESTER PARTS**  
Sept. 1 thru Sept. 30



### Cutterhead Parts

DESCRIPTION	APPLICATION	NUMBER	REG	NOW
Recutter screen-1 1/2 in	3940 3950	E62850	\$156 06	\$122 18
Recutter screen-1 1/2 in	3960 3970	E62855	\$194 91	\$152 60
Recutter screen 1 in	3940 3950	E62849	\$156 06	\$122 18
Recutter screen-1 in	3960 3970	E62854	\$194 91	\$152 60
Recutter screen-3/4 in	3940 3950	E62848	\$156 06	\$122 18
Recutter screen-3/4 in	3960 3970	E62853	\$194 91	\$152 60
Knife	3940 3950 36 required	E61962	\$13 42	\$9 95
Knife	3960 3970-48 required	E61961	\$13 42	\$9 95
Bar	3940 3950 3960 3970	E61960	\$13 40	\$7 65
Stationary knife w/bearing	3940 3950	AE44465	\$197 74	\$158 95
Stationary knife w/bearing	3960 3970	AE44466	\$199 94	\$169 95
Sharpening Stone	3940 3950 3960 3970	AE46064	\$38 94	\$33 25
Bar	3940,3950 3960 3970	E78596	\$6 22	\$4 67
Knife bolt	3940 3950 3960 3970	E83034	\$1 40	\$1 50

### Fan Parts

DESCRIPTION	APPLICATION	NUMBER	REG	NOW
Blower band front	3940,3950 3960 3970	E78174	\$178 29	\$124 78
Blower band rear	3940 3950 3960 3970	AE36535	\$147 84	\$101 45
Fan blade with hardware	3940 3950 3960 3970	AE37844	\$30 37	\$20 60
Fan sheet right-hand	3940 3950 3960 3970	AE45990	\$244 83	\$169 10
Fan sheet-left-hand	3940,3950,3960,3970	AE37290	\$142 44	\$101 25

### PULL-TYPE FORAGE HARVESTER PARTS

Pull-type forage harvesters need wear parts too. And we have them - at low low "Wow!" prices

### Cutterhead Parts

Recutter screens knives wear plates fan and spout parts, hardware, and more. Keep your pull-type John Deere forage harvester operating at peak efficiency with these economical parts

DESCRIPTION	APPLICATION	NUMBER	REG	NOW
Stationary knife	35,38	E53086	\$64 89	\$54 99
Cutterhead knife	3800	E62285	\$88 24	\$75 25
Stationary knife	3800	E58369	\$107 92	\$85 90
Knife bolt	35,38	E40839	\$6 54	
Bolt kit	3800	AE32487	\$24 86	\$21 45
Fan sheet - Welded, right-hand	3800	AE32291	\$290 95	\$205.00
O knife - heat-treated	4-row row-crop unit	E63576	\$36 94	\$29 75