

**HARRISBURG** (Dauphin Co.) — On behalf of Gov. Tom Ridge, Agriculture Secretary Samuel E. Hayes Jr. has announced that the first cost-share funding reimbursements for nutrient-management plans have been distributed to eligible farmers.

"As the Oct. 1 deadline for completed nutrient-management plans draws near, we are pleased that the funds are getting to the farmers who developed the plans," Hayes said. "We encourage all eligible farmers to take advantage of this cost-share program."

The Plan Development Incentives Program provides funding to eligible operators of livestock or poultry operations for up to 75 percent of the cost of their nutrient-management plans.

The plans must be developed by a certified commercial planner or a certified individual

farmer to qualify for reimbursement.

To be considered for the one-time reimbursement, a program application and nutrient-management plan must be completed and approved.

Funding for plans developed by operators of Concentrated Animal Operations (CAOs) is available through Sept. 30.

Guidelines for cost-share rates have been developed by the State Conservation Commission. Applications can be obtained from local county conservation district offices.

For additional information, contact the Agriculture Department's nutrient-management office at (717) 787-3568.

# REED EQUIPMENT SALES

**Ronald Reed, Manufacturer's Rep - 717-532-8297**

700 Baltimore Road, Shippensburg, PA 17257

**Visit With Us During Ag Progress Days - Fri. Sept. 19th - Sun. Sept. 21st.**

## "on the move"

**GRAIN HANDLING FROM Feterl 6"-7"-8"-10"-12" SYSTEMS**

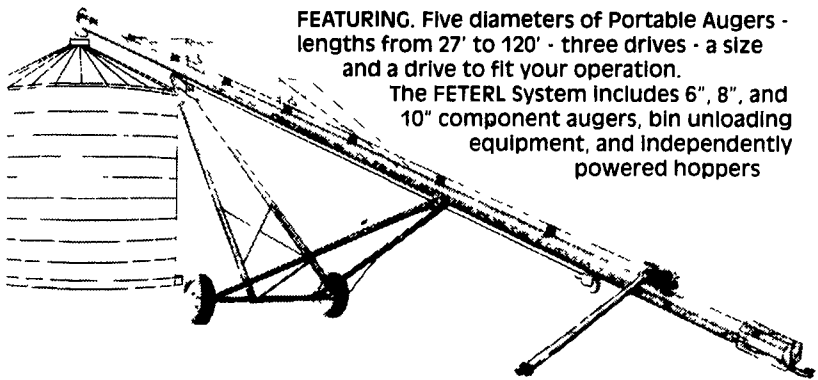

FEATURING. Five diameters of Portable Augers - lengths from 27' to 120' - three drives - a size and a drive to fit your operation.

The FETERL System includes 6", 8", and 10" component augers, bin unloading equipment, and independently powered hoppers

## Feterl HOPPERS

**10" EASI-ROLL, LOW PROFILE TRUCK HOPPER**

Hydraulic, Electric, Gasoline Or Tractor Driven PTO

Optional Tow Hitch

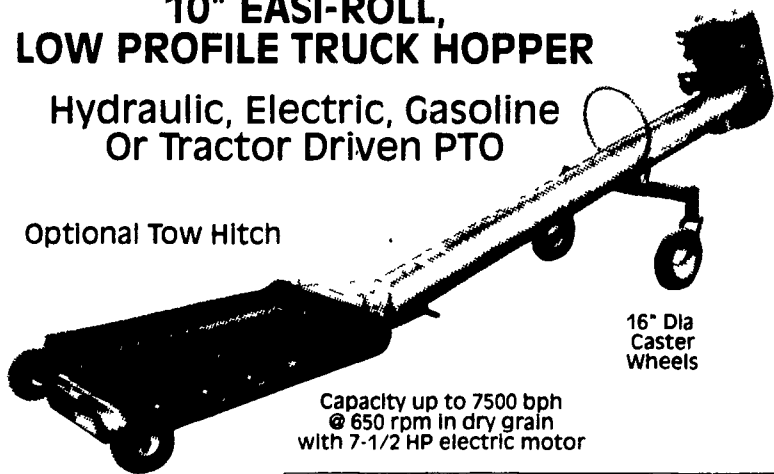

16" Dia Caster Wheels

Capacity up to 7500 bph @ 650 rpm in dry grain with 7-1/2 HP electric motor

Hopper Opening  
Length - 52"  
Width - 38"  
Depth - 9"  
Discharge Height  
Up to 33"  
Total Hopper Length.  
190"  
10-1/2" Hopper Wheels

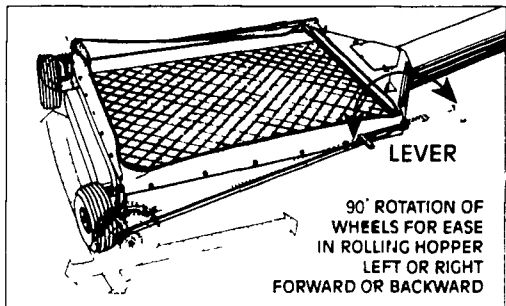

90° ROTATION OF WHEELS FOR EASE IN ROLLING HOPPER LEFT OR RIGHT FORWARD OR BACKWARD

## ROTATING GRAIN CLEANER

Dual cleaning action removes both coarse and fine material Full length inner cone screen for high capacity

**MODEL 23-090**

One power source drives loading auger cleaner and fines auger



**DRIVE OPTIONS**  
Electric  
PTO  
Gas  
Hydraulic

**Feterl**

## Taylor-Way TANDEM DISC HARROW

**TAYLOR PITTSBURGH IMPLEMENT**



### 350 Wing-Fold & 351 Non-Folding

- Heavy-duty main frames constructed of 3/8" x 4" x 4" tubular steel for strength
- Both wing-fold and non-folding models available
- Equipped with heat-treated scraper blades mounted on spring steel scraper handles
- Adjustable 3/8" x 3' x 5" gang tubes adjust from 15° - 21°
- Simple front to rear leveling with spring loaded adjustment rod
- Hydraulic flat fold wings on folding model Wings lock into working position with adjustable locks
- Spring cushion or rigid bearing connectors
- 7-1/2", 9" or a combination 9" front and 7-1/2" rear disc spacing available
- Dual transport wheels are standard on all models

## THE GB LINE 570 Quick-Attach Loader

11' 8" SELF LEVELING LOADER PROVIDES HIGH PERFORMANCE FOR 40-115 HP TRACTORS



Futuristic Self Leveling Loader for Today's Customers Features Compact Size and Styling to Compliment Your Tractor at a Competitive Price

• Low profile fit provides a perfect match for standard tractor PTO's

*Quick Draw*

Latch Attach