

CUT FEEDING TIME WITH WEAVERLINE SILAGE CART

Be Sure To Consider
Weaverline Silage Cart

WHY?

- Feeding is Right At Your Fingertips
- Improves Dairy Feeding

You Will Enjoy Feeding Cows With The Easy Quiet & Fast Weaverline Cart... Many Sizes Available

- ★ 20% Larger Than The "Best Seller" Model 430
- ★ Larger Size For The Larger Herd
- ★ Full 36 Bushel Capacity
- ★ Extension Side Kit Available To Increase The Capacity On All Models.

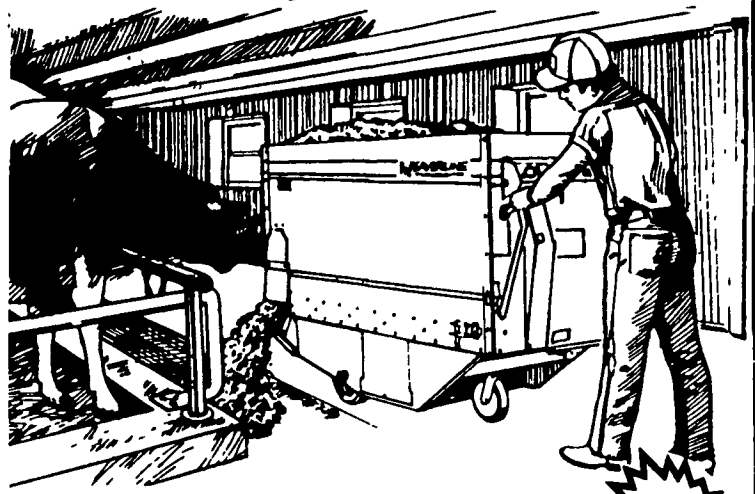

4 SIZES
AVAILABLE

420 - 424 - 430 - 436



Gruett's FORAGE RACK



Forage Rack for the
• Aluminized steel sides and roof for longer wear.
• Available with right or left unload
• Pintle apron chain & pintle cross conveyor.

3 Models To Choose From



WAGON GEAR

74" tread width, all welded construction, one piece spindle, bolster stakes 38" or 42" spacing, tow plate standard, grease fittings, short turning automotive type steering, tie rods located behind hefty box axle. (New wishbone type tandem axle permits operation in heavy mud without clogging.)

NEW WISHBONE TYPE TANDEM ABSOLUTELY NO MUD CLOGGING



Mayrath InLine Drive

Mayrath introduces the all new "InLine Drive" series of portable grain augers. Mayrath has combined operational efficiency with long term dependability providing you with a high quality, GALVANIZED auger at a very affordable price. The revolutionary "InLine Drive" system minimizes the number of moving parts... greatly reducing costly down-time and maintenance in the future.

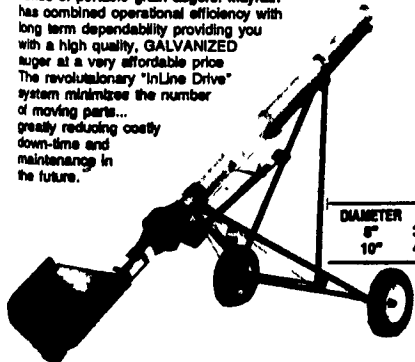

DIAMETER	CAPACITY	LENGTH
6"	3200 BPH	32', 42', 52', 62', 72'
10"	4800 BPH	32', 42', 52', 62', 72'

ASK ABOUT THE SWING-AWAY



Platform Feeder

For transferring any feed material from dump boxes, truck boxes, or rear unloading wagons.

Dump whole loads, and head back for more! Needs no tending. Eliminates delays, plugging and down-time.

right-hand delivery shown

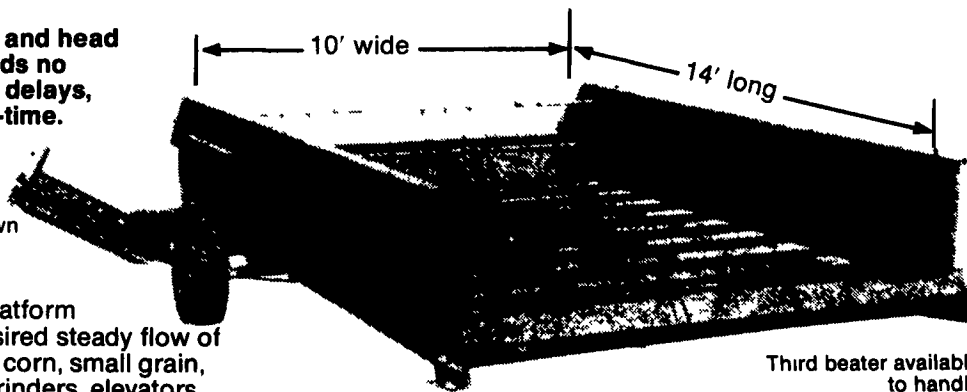

The Kelly Ryan Platform Feeder puts the desired steady flow of fresh-cut silage, ear corn, small grain, etc., into blowers, grinders, elevators, or any hopper, without spilling and completely unattended. Your choice of right or left delivery.

Your choice of drives... including P-T-O.



Hydraulic drive Flow control valve permits variable speed unloading. Use the same tractor to power blower, grinder, etc.

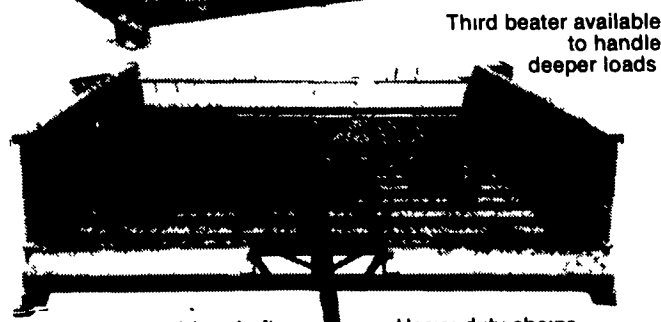

Third beater available to handle deeper loads

1 1/2" Apron drive shaft. 1/4" Steel floor with 3" V reinforcing.

Heavy-duty chains driven by specially built gear box.

Quick-attach tongue for moving from spot to spot or farm to farm.



Electric drive Crank adjusted motor mount permits variable speed unloading to suit any particular load.

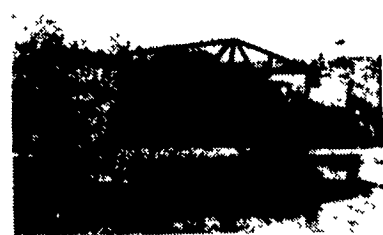

Knocked-down, ready for the road

Your Source For Quality Grain Handling Equipment
A premium quality galvanized auger designed for low maintenance operation.



The InLine Drive
Unique in design, high in efficiency.

The gearbox is located "InLine" with the actual auger flighting. The outer tube is expanded to allow unobstructed and efficient flow of grain past the gear drive section. This design proves to be both economical and low maintenance in operation.

RYDER SUPPLY CO.

539 Falling Spring Road
P.O. Box 219
Chambersburg, PA 17201-0219
Phone 717-263-9111