

Cow hoof trimming trailer, hydraulic, has own hyd. pump, motor, good condition. 717-668-3442

**CRAWLER LOADER**  
CASE 450, good condition, \$6,000. 410-833-9091

Forklift, TCM Model FCG25 propane, cushion tires, 189" Max fork height, sideshift, 4300# capacity; Toledo platform scale, 2000# capacity; 16' flatbed truck body, steel floor, dump hoist. 609-467-2119 leave message.

New Holland 795 manure spreader, new net, top beater, hydraulic endgate,  
**\$6,200**

**(301) 791-1200**

## A CLASS ACT

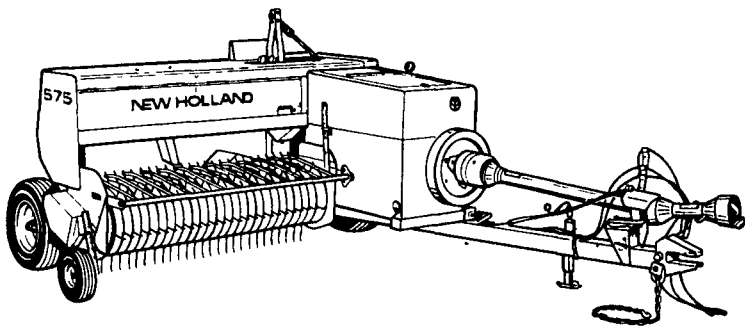

## BEST IN THE FIELD

The New Holland "575" square baler tops every baler in its class . . . for capacity, bale quality and reliability

- **Revolutionary rotary feeding system.** Mechanically simple, but unbeatable for hay handling
- **Exclusive Wide Super-Sweep™** pickup that's 75" wide to get all the hay.
- **Heavy-duty materials** in the bale case and plunger
- **Gear-driven knotters or twisters.**
- **Increased load capabilities** handle extra capacity.



See us for the New Holland "575" square baler. **NEW HOLLAND**

## ALL-NEW SUPER BOOM™

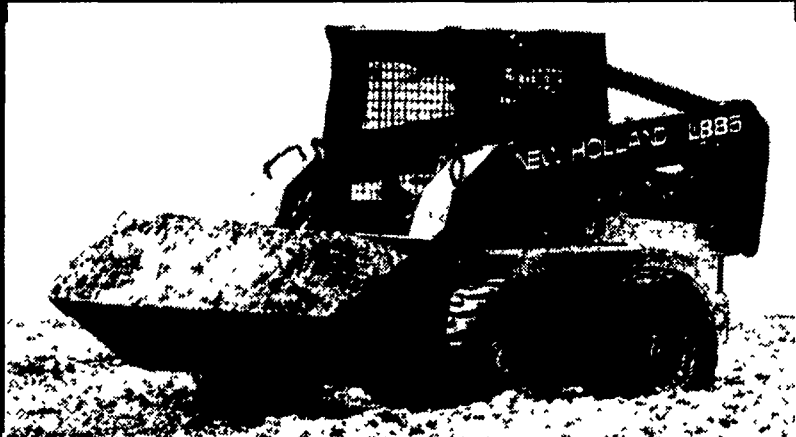

## THE HEAVYWEIGHT CHAMP

When you're looking for a skid-steer, there's the challengers and then there's the champ. Well say hello to the undisputed champ in the all-new Model LX885 New Holland Super Boom™ skid-steer loader.

It has a 60-horsepower, turbocharged diesel engine for the ultimate in power. Its massive 2,200-lb. operating load picks up where all others leave off. Of course, it has the features you expect from New Holland, such as the best speed, stability, visibility, lift height and dump reach in the industry. Add that to the Pick Up 'n Go™ universal attachment system and there's nothing it can't handle. Stop by today and put the champ to work for you.



**NEW HOLLAND**

### QUALITY USED EQUIPMENT FOR SALE

- |                                 |                              |
|---------------------------------|------------------------------|
| • IH 584 Tractor                | • NH 1033 Bale Wagon         |
| • Bobcat M700 Skid Loader       | • NH 489 Haybine w/New Rolls |
| • NH 791 Spreader               | • NH 499 Haybine w/New Rolls |
| • NH 30 Blower                  | • JD 1219 Mower Conditioner  |
| • NH 770 Harvester              | • NI 4151 Bar Rake           |
| • NH 782 Harvester              | • NH 315 Baler w/Thrower     |
| • NH 890 Harvester              | • NH 326 Baler               |
| • 890A Auger Base w/890W Pickup | • (3) NH 489 Haybine         |
| • 890 3 Row N Corn Head         | • NH 411 Discbine            |
| • Gehl Forage Box & Gear        | • JD 8250 Grain Drill        |



# The Word Is Out

End of Year  
**PARTS SALE**



**GET DOWN TO YOUR AGCO DEALER FOR INCREDIBLE DEALS ON PARTS**

- Airville, PA**  
FARMERS EQUIPMENT  
3524 Delta Rd.  
717-862-3967
- Beavertown, PA**  
B&R FARM EQUIPMENT  
RR 1 Box 2424 (Rt. 522 South)  
717-858-8175
- Bechtelsville, PA**  
MILLER EQUIPMENT  
144 Stauffer Rd  
610-845-2911
- Carlisle, PA**  
CARLISLE FARM SERVICE  
260 York Rd.  
717-243-4419
- Chambersburg, PA**  
CHAMBERSBURG FARM SERVICE, INC.  
975 South Main St.  
717-264-3533
- Columbia Cross, PA**  
COLUMBIA CROSS ROAD  
RD 2, Box 62  
717-297-3873
- Denton, MD**  
SHAFFER EQUIPMENT CO.  
26193 Burrsville Road  
410-479-1477
- Elizabethtown, PA**  
HERNLEY'S FARM EQUIP.  
2095 South Market St.  
717-367-8867
- Frederick, MD**  
REICHS FORD TRUCK & TRACTOR  
8016 Reichs Ford Rd  
301-662-7622
- Honesdale, PA**  
MARSHALL MACHINERY, INC.  
5 Miles East of Honesdale  
717-729-7117
- Ingleside, MD**  
GIBSON FARM EQUIPMENT  
3120 Goldsboro Rd., PO Box 13  
410-758-0262 — 410-482-8911
- Lineboro, MD**  
WERTZ FARM EQUIPMENT  
4132 East Main St  
410-374-2672
- Martinsburg, PA**  
BURCHFIELD'S, INC.  
112 S Railroad St.  
814-793-2384
- New Oxford, PA**  
SIBERT EQUIPMENT  
1175 Brickcrafters Road  
717-624-8763
- Punxsutawney, PA**  
ROBERT H. LONDON FARM SUPPLY  
Route 3, Box 381  
814-938-7444
- Quarryville, PA**  
GRUMELLI FARM SERVICE  
929 Robert Fulton Hwy. (Rt. 222)  
717-786-7318
- Sandy Lake, PA**  
SANDY LAKE IMPLEMENT  
3675 Sandy Lake Rd.  
412-376-2489
- Stoneboro, PA**  
ELDER SALES SERVICE, INC.  
488 Greenville - Sandy Lake  
412-376-3740
- Washington, PA**  
SCHOTT EQUIPMENT SALES  
2075 Henderson Ave.  
412-228-2476 — 412-222-3780

## AGCO® ENGINE KITS

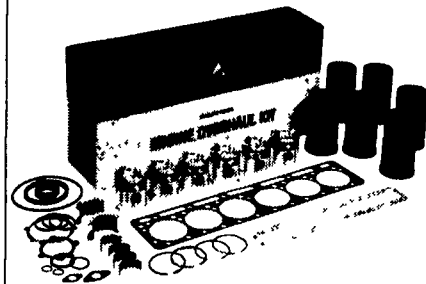

- Complete overhaul kits
- Quality OEM parts
- Full one-year warranty
- Kits for most applications
- Saves you time and money

## AGCO® LUBRICANTS



- Premium Quality
- Custom Additives
- Meet/Exceed OEM specs
- Protect your warranty

## AGCO® PRESSURE WASHERS

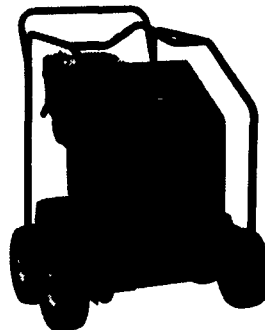

- Tough machines for tough jobs
- Gas and electric units available
- Heavy duty construction
- Heavy duty warranty

## AGCO® BATTERY CHARGERS

- Perfect for home shop or farm
- Testers and cables also available

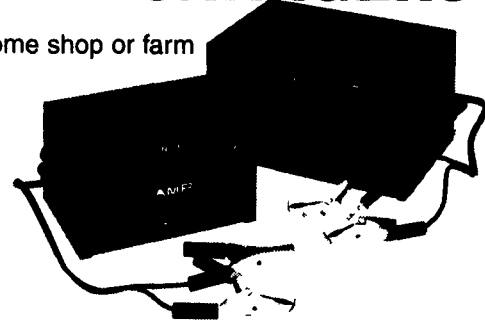

## AGCO® FILTERS

- Our filters are 99% guts
- Designed for heavy duty applications
- Made to OEM specifications

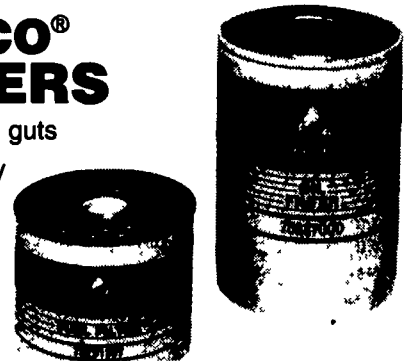

## The Word Is Out

Quality Parts • Quality Prices • Quality Service