

RINGO TRACTORS

COME SEE US AT:
SUNBELT AG EXPO - OCT. 15-17

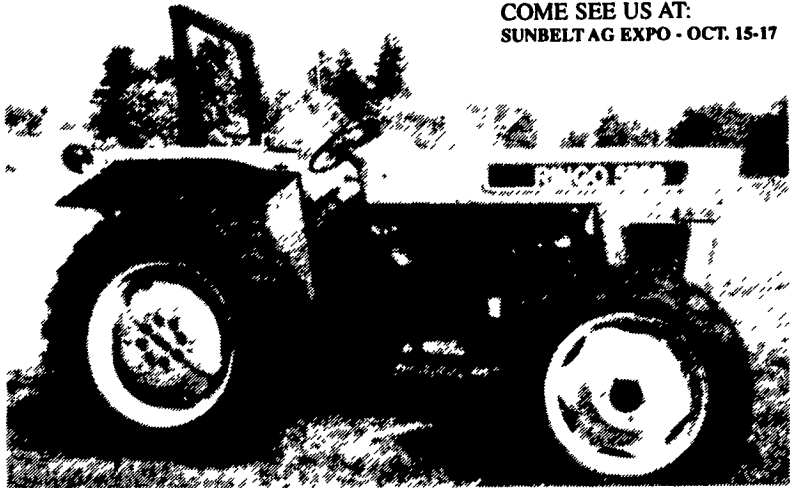

THE RIGHT TRACTOR AT THE RIGHT PRICE

TWO MODELS AVAILABLE

- | | | |
|-----------------------------------|---|-----------------------------------------------|
| 30 hp \$8,750 | & | 50 hp \$14,900 |
| *WATER COOLED DIESEL ENGINE | | *HYDROSTATIC STEERING |
| *8 SPEED DUAL RANGE TRANSMISSION | | *MANY STANDARD FEATURES |
| *LIVE HYDRAULICS (2 STAGE CLUTCH) | | *FINISH ASSEMBLY & QUALITY CONTROL IN AMERICA |
| *SAME DAY PARTS AVAILABLE | | *DIFFERENTIAL LOCK |
| *LIVE PTO | | |

MANUFACTURED IN CHINA, ASSEMBLED IN AMERICA
BACKHOES & LOADERS AVAILABLE "FULL" SUPPLY OF PARTS IN STOCK
CALL US FOR THE DEALER CLOSEST TO YOU
RINGO HILL FARMS EQUIPMENT CO., INC.
1624 ROUTE 212, QUAKERTOWN, PA. 18951
PHONE 610-346-7340 FAX 610-346-8041

BARMANS EQUIPMENT

PO 204 Country Rt. 49
Slate Hill, NY 10973
Phone: (914) 355-6875

DE CO CATTLE & EQUIPMENT

RD #2 Box 181
Wellsboro, PA 16901
Phone (717) 724-7318

TERRY GERHART

RD 3 Box 257
Coudersport, PA 16915
Phone (814) 647-8803

PEETS TRACTOR

Box 145 Rt. 11
Nicholson, PA 18446
Phone (717) 942-4427

ROVENDALE AG & BARN EQUIPMENT

RD #2 Box 210C
Watson, PA 17777
Phone (717) 538-9564

WELLS CAMPING CENTER

8459 Olean Road
Holland, NY 14080
Phone (716) 537-2639

JD 4430 Quad Range
S.G.B., 4500 Hrs., 135-H.P., 90% Rubber - Dual Outlets - New Clutch + Update Kit In Trans. - A-1 Shape - New Paint
\$16,950
717-249-2317
Farm Equipment Repair

Bush Hog Model 245 12' Offset Disc
With Buster Bar, New Disc Blades, Good Condition
\$2900 . . . OBO
Lancaster Co.
717/529-2386

It's Not Just A Matter of Time!
Built to last, Stoltzfus Feeders offer more than a lifetime of use

Available in a variety of lengths, this wagon is ideal for feeding cattle in meadows or feed lots.

- Pan constructed of 1/4" boilerplate
- Slant bar or self-locking head locks adjustable for smaller livestock & easily removed for downed animals
- Easily attached dolly for greater maneuverability
- Head lock model has front gate for easy access to tray

Call us also for Bale Racks

Well Built in a variety of lengths!

STOLTZFUS
Gates • Slant bar sections • Head locks • Gutter grates

For a free brochure or more information call 610/273-3603

Clinton Tractor & Implement Co Clinton NY 315/853-5701	Derstein Farm Equipment East Berlin PA 717/292-1856	Walter G. Coale, Inc Churchville MD 410/879-1491	Shade Mountain Rental & Supply Port Royal PA 717/436-9728
James Bergen Slate Hill NY 914/355-4571	BHM Farm Equipment Annville PA 717/867-2211	Binkley & Hurst Bros., Inc. Littiz PA 717/626-4705	Millard Equipment, Inc. Lowville NY 315/376-2722
Rolf Greimsmann Nicholson, PA 717/222-4432	Fosterdale Equipment Fosterdale NY 914/932-8611	Zimmerman Farm Service Bethel, PA 717/933-4114	Herman Steffens Detour MD 410/775-2324

CAPACITY KING

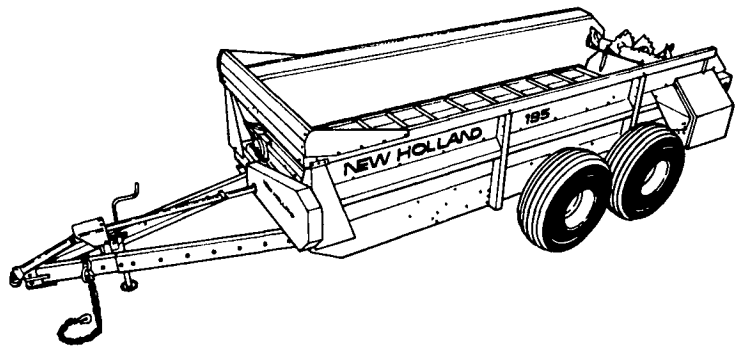

THE BIGGEST

The New Holland Model 195 box spreader is up to your biggest spreading job.

- **Capacity.** The "195" takes on 410 bushels (440 cu. ft.) without flinching.
- **Strong construction.** Corrosion-resistant steels last and last. And an HDPE floor means smooth unloading, even in cold weather.
- **Bonded Protection warranty.** If the polyethylene floor fails or the sides rust, we'll replace them free for 12 years.
- **Fast clean out...** even with this big-capacity strong box.
- **Large tandem oscillating wheels.** Allow faster ground speeds in rough terrain, with less ground compaction.



Check out our biggest New Holland spreader...from the biggest name in spreaders.

NOW IS THE TIME...

To schedule your pre-season repairs and reconditioning of tractors and equipment

BHM FARM & LAWN EQUIP.

SALES - PARTS - SERVICE
Route 934 - 2 Miles North of Annville, PA
Telephone 717-867-2211

KUBOTA KUBOTA KUBOTA KUBOTA KUBOTA KUBOTA KUBOTA KUBOTA KUBOTA

ERB & HENRY EQUIP., INC.

PARTS - SERVICE - SALES - RENTALS

SINCE 1898

- | | |
|----------------|---------------------------|
| • Kubota | • Case IH Parts & Service |
| • Cub Cadet | • Woods |
| • Befco Equip. | • John Bean |
| • Brouwer Turf | • Meyers Snow Plows |
| | • Howard Price |
| | • Grasshopper |

FARM EQUIPMENT IN STOCK

- DEMO UNITS:**
CASE IH 415 Packer Mulcher, 10 1/2"
CASE IH 183 6 Row Cultivator
(2) 8x8x18 Farmco Bale Wagons
SPECIAL PRICE
NEW KUBOTA TRACTORS IN STOCK
16 HP to 90 HP

BEFCO 2-STAR & 4-STAR TEDDERS FIELD READY

USED EQUIPMENT

- | | | |
|--------------------------------------------------------------------------------------------------------------------------------------------------------------------------------------------------------------------------------------------------------------------------------------------------------------------------------------------------------------------------------------------------------------------------------------------------------------------------------------------------------------------------------------------------------------------------------------------------------------------------------------------------------------------------------------------------------------------------------------------------------------------------------------------------------------------------------------------------------------------------------------------------------------------------------------------------------------------------------------------------------------------------------------------------------------------------------------------------------------------------------------------------------------------------------------------------|--------------------------------------------------------------------------------------------------------------------------------------------------------------------------------------------------------------------------------------------------------------------------------------------------------------------------------------------------------------------------------------------------------------------------------------------------------------------------------------------------------------------------------------------------------------------------------------------------------------------------------------------------------------------------------------------------------------------------------------------------------------------------------------------------------------------------------------------------------------------------------------------------------------------------------------------------------------------------------------------------------|-----------------------------------------------------------------------------------------------------------------------------------------------------------------------------------------------------------------------------------------------------------------------------------------------------------------------------------------------------------------------------------------------------------------------------------------------------------------------------------------------------------------------------------------------------------------------------------------------------------------------------------------------------------------------------------------------------------------------------------------------------------------------------------------------------------------------------------------------------------------------------------------------------------------------------------------------------------------------------------------------------------------------------------------------------------------------------------------------------------------------------------------------------------------|
| <p>TRACTORS:</p> <ul style="list-style-type: none"> • Case 1845C Skid Loader 3100 Hrs. • Gehl 4500 Skid Loader • IH 140 FH w/Woods 5' Mower & 5' Snow Plow • IH 154 Cub Low Boy • IH 154 Cub Low Boy w/5 Ft. Sickle Bar • IH 404 Gas, Dual Turf Tires, W/O 3 PL Hitch • IH 684, Ag Tires, Engine Overhauled • 1987 Ford 1310, 2WD w/Ford Loader (Ex. Cond.) • Ford 5610, 2wd W/7700 Ford Loader 1400 Hrs., (Nice Shape) • MF 2135 Gas, Turf Special, Nice Clean Tractor • MF TO35, Turf Tires, Nice • MF TO30, Ag Tires, New Paint • JD M w/Loader, Runs Good • Farmall H Nice Shape • Farmall Cub w/Front Sweeper Broom & Belly Mower (yellow & white) • 184 Cub LowBoy w/Cab & 5 Ft. Mower • Farmall IH 340D, WF-FH • Farmall Cub w/5 ft. Sickle Bar • Farmall F20 (Restored) • Farmall A w/1-Bottom Plow, Nice Shape, Needs Paint • Case 400 Gas (Restored) Nice • Farmall BN w/Bucksaw (Restored) • Yammar 187, PS, 2WD w/ 60" Woods, Nice Shape | <p>COMBINES:</p> <ul style="list-style-type: none"> • IH 744 Wide Cornhead for 715, (For Parts) • MF 44 4RW, CH, Nice Shape <p>OUTDOOR POWER EQUIP.:</p> <ul style="list-style-type: none"> • Kubota GF1800 2WD, 60" Deck, Grass Catcher (Nice Shape) • Honda 4514 Hydro 38" Deck Bagger Attachment (Like New) • National 5 Gang Reel Mower w/11 HP Engine, Pull Type • Toro 7 Gang Pull-Type Golf Course Mower (for parts) • National 3 Gang Triplex, 84" Cut, 1-Electric Start, 1 - Manual Start • Dixon ZTR w/30" Cut & Bagger, Nice • Howard-Price 727 Diesel w/5 Gang Reel Mowers • Steel Cab for IH 154, 185 or 184 Nice Shape • Good Selection Of Older Cub Cadet Lawn & Garden Tractors, All Makes and Models! <p>TILLAGE:</p> <ul style="list-style-type: none"> • Hugo 10 ft. Harrow Roller • Hyd. Transport.....\$1,500 | <p>HAY & FORAGE:</p> <ul style="list-style-type: none"> • NI 272 Cuditioner • IH 445 Baler w/o Thrower (like new) • IH 440 Baler w/Thrower • IH 990, 9 Ft. Mower Conditioner, Field Ready • Hesston 4500 Wire Baler w/Thrower • NH 411 Discbine • NH 479 Haybine Good Rolls, New Wobble Box <p>MISCELLANEOUS:</p> <ul style="list-style-type: none"> • NI Ground Drive Spreader (Needs Wood) • Brouwer Sod Harvester 3000 Ford Tractor w/16" Folding Unit • JD 7000 4-Row Liquid Planter, Plate Type • Landpride 3 pt. Hitch 60" finish Mower, Like New • Case IH 72" 3 Pt. Hitch Finish Mower, Like New • Woods 105 3 pt. Hitch Arm Mower (Real Nice) • Wood 60" Trailing Mower • Woods RM306 6 ft. 3 pt. Finish Mower • Woods RM500 5 Ft. 3 Pt. Finish Mower Demo • MF 5 Ft. 3 Pt. Mower • FMC 500 Gal. Trailing Sprayer w/Boom Piston Pump • 4-Ton Tandem Axle Hydraulic Dump Trailer • Huber Highway Roller, 8-Ton Used Meyers Snow plows |
|--------------------------------------------------------------------------------------------------------------------------------------------------------------------------------------------------------------------------------------------------------------------------------------------------------------------------------------------------------------------------------------------------------------------------------------------------------------------------------------------------------------------------------------------------------------------------------------------------------------------------------------------------------------------------------------------------------------------------------------------------------------------------------------------------------------------------------------------------------------------------------------------------------------------------------------------------------------------------------------------------------------------------------------------------------------------------------------------------------------------------------------------------------------------------------------------------|--------------------------------------------------------------------------------------------------------------------------------------------------------------------------------------------------------------------------------------------------------------------------------------------------------------------------------------------------------------------------------------------------------------------------------------------------------------------------------------------------------------------------------------------------------------------------------------------------------------------------------------------------------------------------------------------------------------------------------------------------------------------------------------------------------------------------------------------------------------------------------------------------------------------------------------------------------------------------------------------------------|-----------------------------------------------------------------------------------------------------------------------------------------------------------------------------------------------------------------------------------------------------------------------------------------------------------------------------------------------------------------------------------------------------------------------------------------------------------------------------------------------------------------------------------------------------------------------------------------------------------------------------------------------------------------------------------------------------------------------------------------------------------------------------------------------------------------------------------------------------------------------------------------------------------------------------------------------------------------------------------------------------------------------------------------------------------------------------------------------------------------------------------------------------------------|

• Used Cub Cadet Parts In Stock

ERB & HENRY EQUIP., INC.

One Mile North of Boyertown, New Berlinville, PA
Hours: Daily 7:30 to 5; Sat. 7:30 to 3

610-367-2169 Fax 610-367-6715

WE SHIP UPS DAILY

KUBOTA KUBOTA KUBOTA KUBOTA KUBOTA KUBOTA KUBOTA KUBOTA KUBOTA