

## KELLER'S FARM MACHINERY

116 Richlandtown Pike  
Quakertown, PA 18951  
215-536-4046

- Ford 3400 G, w/Rear Mounted Forklift
- Ford 2600 D 8 spd, PS
- Ford 2120 4x4, Loader & Cab
- Ford 2000, 4 Cyl., 12 Speed
- Ford 8700 Cab, Air
- Ford TW10 Cab w/ Duals
- Ford TW20 cab, air, 4x4
- Ford 800 w/live PTO
- Ford 4000, PS, live PTO
- Ford 5000 D w/cab
- Ford 1920 4x4 w/Loader
- Ford 3000 G, PS, 8 spd
- Ford 1910 w/Ford Loader
- Ford 340B w/Loader, 3 pt.
- Ford 4610, 8 Speed, New Tires & Paint
- Ford 601, w/Ford Loader
- Ford 8N w/Ford Rotary Mower
- Ford 3400 w/Loader, 3pt PTO
- Ford 3930, 8sp., PS, 400 hrs.
- Ford 3230 w/300 Hrs.
- Ford 3910 Series 2, 8 Spd. w/snow plow
- Farmall Cub w/Woods Mower
- JD 60, PS, 3 pt.
- Case 580C w/cab LBH
- Kubota L175 w/Snowplow & Woods Mower

## MARTIN'S FARM SUPPLY

St. Thomas, PA.  
(717)-369-5702



- Welger RP200 Baler for rent
- Corry Roll-off Self-propelled Wrapper for rent
- 9' Ag-Bag Silage Bagger for rent
- New Balers & Wrappers for sale
- High moisture baling and wrapping experience since May 1988
- Sunfilm Stretch wrap
- UP North Silage Bags
- Up North Bunker Covers
- Call for nearest Dealer

## Liquid Manure Pit Pumps

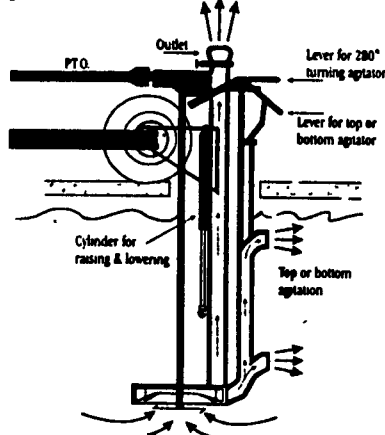

- Available 6-8-10-12 ft.
- Trailer mounted mobility
- Hydraulic lift
- Simple controls
- Dual agitation

## ZIMMERMAN HEAVY DUTY PORTABLE ELEVATORS



WELL BALANCED, RUGGEDLY BUILT FOR MANY YEARS OF TROUBLE FREE SERVICE

From 28 Ft. to 48 Ft. Available

- 28 Ft. - \$2,195
- 32 Ft. - \$2,350

880 Series "Skeleton Elevator" also available

- IH 3688 Tractor, Excellent.....\$18,900
- IH 1086 Tractor.....\$13,900
- IH 1066 Tractor.....\$8,400
- CIH 585 Tractor, Super Sharp.....\$10,500
- IH 1206 Tractor, Painted.....\$7,600
- Deutz 100-06 Tractor.....\$6,400
- MF 65 Tractor, Diesel, Engine Completely Rebuilt, Painted.....\$5,400
- NH 454 Skid Loader (gas).....\$8,500
- Gehl TR3038 Cornhead.....\$1,400
- NI 323 Corn Picker, Excellent.....\$3,000
- JD 400 Rotary Hoe.....\$1,200
- (6) NH 402 Crimpers



## MILLER'S REPAIR

1 Mile North of Bird in Hand  
8 Miles East of Lancaster  
Ph. 717-656-6109

# PEAK PERFORMERS

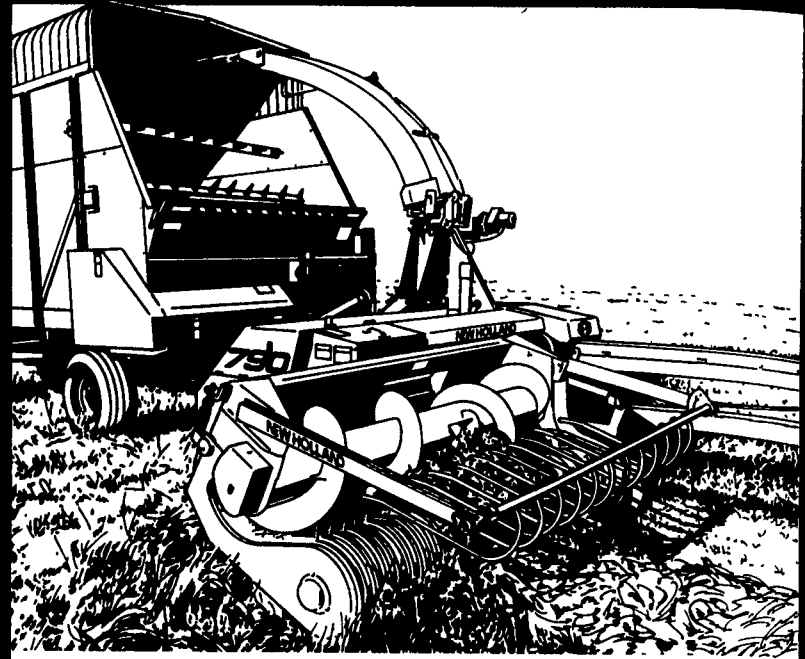

## READY WHEN YOU ARE

Durable. Dependable. Powerful. New Holland forage harvesters will be there when you need them, so you can harvest your crop on time, season after season.

Four power-driven feedrolls carry materials into the cutterhead for an even, controlled cut, and the rugged 12-knife cutterhead delivers a fine uniform chop.

New Holland forage harvesters. Ready when you are.



NEW HOLLAND

## REACH FOR THE SKY!



## MAKE SHORT WORK OF TALL SILOS

The Model 60 is a big-capacity 540-rpm forage blower built to center-fill silos 100' tall. It features a 37" diameter feed hopper that makes positioning and unloading with cross conveyers easy.

A large 12" feed auger moves crop to the 60" fan for maximum blowing efficiency. The Model 60 forage blower also features:

- Eight adjustable, replaceable paddles
- Heavy-duty, shearbolt protected PTO
- Reversible blower band
- Adjustable air gate
- 9' telescoping pipe
- Adjustable wheels

So reach for the sky with the Model 60 forage blower. Stop in today and we'll show you how to make short work of tall silos.



NEW HOLLAND

Call for **SPECIAL PRICES** on **BLOWERS**

### QUALITY USED EQUIPMENT FOR SALE

- Allis Chalmers 7060 Tractor
- MF 165 Tractor
- AC K Combine, 3RN & 2 RW Corn Heads
- NH 770 Harvester
- NH 892 Harvester
- Zimmerman Forage Box, 16 Ft. w/Roof Hyd. Drive 3 Beaters, 12-Ton Tandem
- NH 849 Round Baler
- NH 315 Baler w/Thrower
- NH 326 Baler
- (3) NH 489 Haybine
- NH 495 Haybine
- NH 411 Discbine
- JD 13 Single Disc Grain Drill w/Roof Hyd. Drive 3 Beaters, 12-Ton Tandem
- AC2600 16 Ft. Disc Harrow \$4,695

## BHM FARM & LAWN EQUIP.

SALES - PARTS - SERVICE  
Route 934 - 2 Miles North of Annville, PA  
Telephone 717-867-2211

## TRAIL AGI-POMPE

32' AND 42' FOR LAGOONS

GREAT PERFORMANCE IN HOG OR DAIRY MANURE

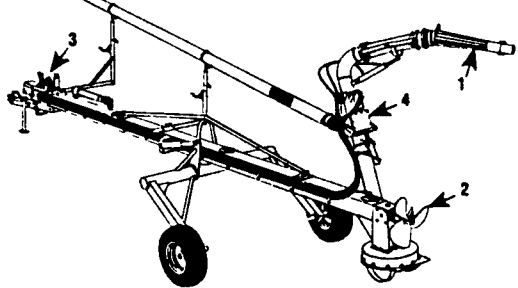

### In Stock For Immediate Delivery

- 1- Highly articulated nozzle designed to slice and break the top crust from above the manure level as the propeller homogenizes the liquid with the remaining floating chunks
- 2- 24" dia. mixing propeller providing full time agitation up to 21,500 US GPM even when loading a spreader
- 3- Hydraulic controls can be operated from tractor seat.
- 4- Rotative directional valve designed to be operated at low R P M without stopping the PTO

Gear box oil bath protected by a greaseable 3 seals mechanism on each shaft.

AVAILABLE WITH MULTIPURPOSE OPTION TO ALSO CLIMB INTO CONCRETE PITS UP TO 14' DEEP.

**RENTAL SPREADERS & PUMPS Available**

**HOULE** FARM EQUIPMENT MANUFACTURER

"We're Here To Serve You"

## SNOOK'S EQUIPMENT

RD 3, Box 130, Mifflinburg, PA 17844  
717-966-2736  
Ask For Ernest Or Dean

## Retire Your Current Spreaders!

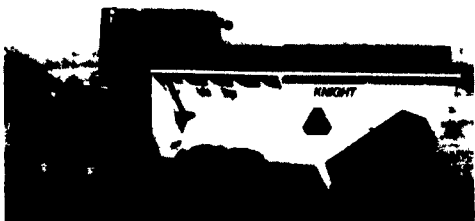

Get the soil nutrients needed to Grow Your Corn Crop this year. If you have pen pack, sticky feed lot or slurry-type material that needs to be spread fast... and spread evenly, you need the **KNIGHT PRO-TWIN SLINGER**



Stop in and see the **KNIGHT Model 8014** today at

## KNIGHT 3000 Series Reel Auggie Mixer

Less Pressure, Friction and Wear...

Faster Mixing and Better Feed Quality...

All Features of the Knight Reel Auggie

Blends gently lifting, fluffing and tumbling the entire load, reducing mix time, power requirement, machine wear and dead spots  
Model 3250 in stock



## ROVENDALE AG & BARN EQUIP.

WATSONTOWN, PA 17777  
717-538-9564 OR 717-742-4226

Exit 31, I-80 to I-180 Watonsontown Exit  
Hours Mon-Fri 8 to 5, Sat 8 to 12

