

National Dairy Council Reviews Dietary Guidelines

ROSEMONT, Ill. — "The U.S. departments of Health and Human Services and Agriculture and the committee members who represented them are to be congratulated for their work in developing the 1995 Dietary Guidelines for Americans," said Greg Miller, Ph.D., F.A.C.N., vice president of nutrition research for the National Dairy Council.

"Given the growing body of nutrition information and the ever-changing lifestyles of Americans, the new guidelines represent a complex but important step toward directing our country's eating habits."

The 1995 edition of the Dietary Guidelines for Americans, as released recently, are intended to be the primary source of dietary information for Americans over

the age of two. To reflect new nutritional findings, the guidelines are reviewed and revised, if necessary, every five years.

"As the new guidelines are put to use," added Miller, "we're hopeful future discussions will build upon today's announcement by taking into consideration the many studies which indicate that children have different nutritional needs than adults."

In a recent National Dairy Council survey, 72 percent of health care and nutrition professionals surveyed said separate dietary guidelines for children would be useful. Several national nutrition organizations share this belief, including The American Dietetic Association, the American Institute of Nutrition, the National Dairy Council and the

American College of Nutrition.

"Nutritional guidelines for children need to consider several aspects even when dealing with health maintenance," said Carolyn Abitbol, M.D., F.A.A.P., F.A.C.N., representative of the American College of Nutrition. "The different phases of growth — infancy, childhood and adolescence — should be addressed with attention towards physical, neurological and emotional growth."

These phases of growth are recognized in the National Institutes of Health Consensus Statement on Optimal Calcium Intake. The statement recommends varying levels of calcium intake throughout an individual's life.

For example, NIH recommends that a child of five years of age consume 800 mg of calcium daily,

whereas they recommend an individual of 15 years of age consume between 1,200 mg and 1,500 mg of calcium daily.

Rebecca Mullis, Ph.D., R.D., president of the Society for Nutrition Education, suggests the guidelines be communicated as consistent scientific message targeted to specific audience segments, such as children and parents.

"Americans' food choices are influenced by diverse interests, beliefs, age, income levels and ethnicity — the language within the guidelines should reflect this diversity," Mullis said.

The guidelines were developed

to communicate to Americans the components of a healthy diet to reduce the risk of chronic disease. The guidelines evolved from the Dietary Goals for the United States, which was issued by the U.S. Senate Select Committee of Nutrition and Human Needs in 1977.

The National Dairy Council is a non-profit organization that initiates nutrition research, implements education programs and communicates scientific information on nutrition issues to health professionals, educators and others concerned about fostering a healthier society. NDC is a division of Dairy Management Inc.



FOR WHEN THE GOOD EARTH ISN'T SO GOOD.

This Rotary Disc Mower Conditioner will get you out of any tight spot in a hurry.

The 1340's innovative 12 foot center-pivot is designed for **fast cutting**. And its long, 110 inch conditioner makes for even **faster drying**. You'll get unmatched **maneuverability** with the 1340, and it's easy to set for swathing or fluffy windrows.

A 12 foot cutting width and a **revolutionary** mechanical driveline guarantee **top efficiency**.

All 16, high-speed, swingaway knives are

designed to cut right through rough spots in damp and problem fields. Mounted on **low-maintenance** rotary discs, the knives are reversible for twice the life.

See your AGCO Hesston dealer today. Ask about **flexible financing** through Agrifin Credit Acceptance Company.

C.J. WONSIDLER BROS.
Finland Rd., Quakertown, PA
215-536-1935 / 215-536-7523
Rts. 309 & 100, New Tripoli, PA
610-767-7611

STANLEY'S FARM SERVICE
RD 1, Box 46 Klingerstown, Pa.
717-648-2088

UMBERGER'S OF FONTANA, INC.
RD 4, Box 545 Lebanon, Pa.
717-867-2613



HESSTON
THE PRIME LINE

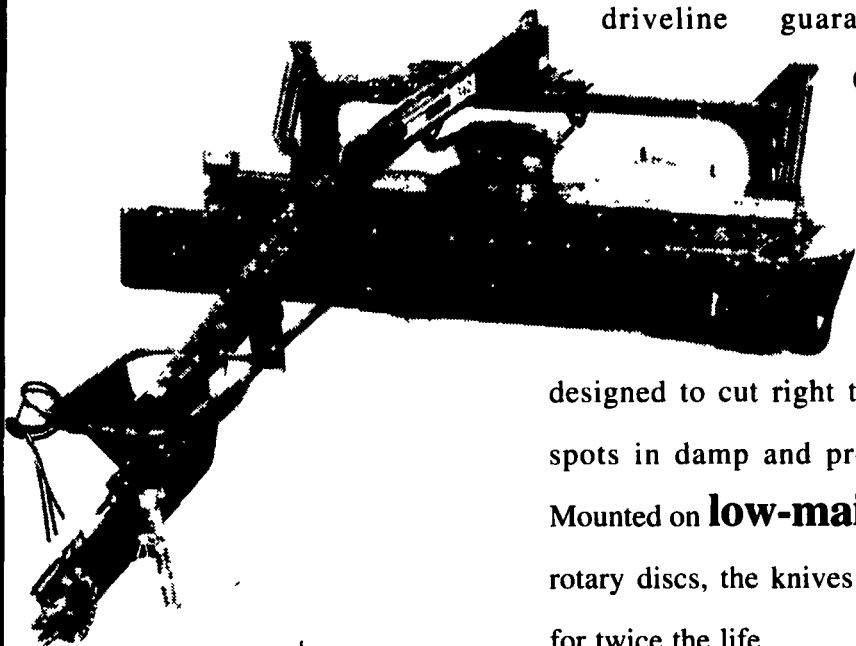

HESSTON
THE PRIME LINE

HERNLEY'S FARM EQUIPMENT, INC.
2095 S. Market St. Elizabethtown, Pa.
717-367-8867

STOLTZFUS FARM SERVICE, INC.
Rts. 10 & 41 Cochranville, Pa.
215-593-2407

ZIMMERMAN'S FARM SERVICE
School Road, Rt. 1 Bethel, Pa.
717-933-4114

D. W. OGG

Frederick, MD 301-473-4250
Westminster, MD 410-848-4585

BUILT TO HANDLE STIHL TERRITORY.

- Top Handle design
- Built in ring rope
- Excellent power/weight ratio
- Side access chain tensioner
- Lifetime ignition warranty
- Easy to reach controls

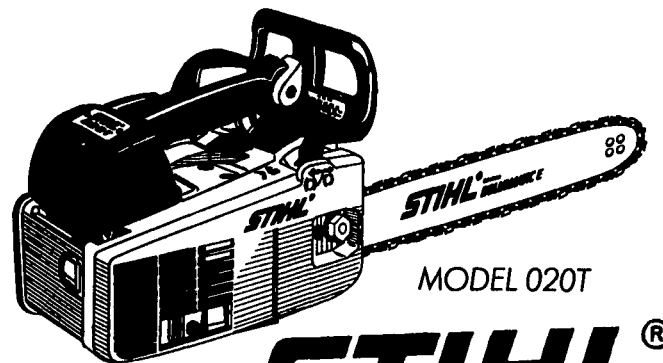

STIHL
Number One Worldwide

Available at these servicing dealers

Airville
WOODBINE MOWER & SAW CO.
1268 Woodbine Rd.
717-862-3271

Dallastown
TRI-BORO CONCRETE, INC.
436 Locust St.
717-246-3095
1-800-632-9018

East Earl
GOODS LAWN & GARDEN CENTER
Route 23
717-354-4026 Ext. 34

Elizabethtown
MESSICK FARM EQUIPMENT, INC.
Rheems Exit-Rt. 283
Elizabethtown, PA
717-367-1318, 717-653-8867

Ephrata
WES STAUFFER ENGINES & EQUIPMENT
23 Pleasant Valley Rd.
717-738-4215

Ephrata, Hershey
HOLLINGER'S LAWN & GARDEN EQUIP.
Ephrata, Pa. 717-738-1131
717-656-2710
Hershey, PA 717-533-4060

Gap
GAP POWER EQUIPMENT
Corner of Rt. 30 & Rt. 697
717-442-8970

Hummels Warf
HUMMEL'S TEXACO
Rt. 11 & 15
717-743-7459

Jonestown
BLUE MOUNTAIN ENTERPRISES, INC.
Rt. 72 South
717-865-2994

Lititz/Lebanon
BOMBERGER'S LAWN & GARDEN
Lititz: 717-626-3301
Lebanon: 717-272-4155

Lovysville/Carlisle
GUTSHALL'S INC.
Lovysville, PA - Carlisle
717-789-4343 717-249-2313

Oxford
ENFIELD EQUIPMENT
6800 Limestone Rd.
610-932-8858

Palmyra
HERR'S REPAIR SHOP
RD 2, Box 115A
717-838-1549

Palmyra
WEAVER'S LAWN & GARDEN
740 W. Main St.
717-838-5999

Port Trevorton
IVAN MARTIN'S SAW SERVICE
Rt. 1, BOX 688

Reamstown
EAGLE RENTAL CENTER
Rt. 272, Reamstown Traffic Light
717-336-3945

Ronks
A & B SALES & SERVICE
370 Newport Road
2 Miles South of Rt. 23
Along 772 Thru Monterey

Schaefferstown
MARTIN HARDWARE & EQUIPMENT CO.
Rt. 501 1/2 Miles South of Schaefferstown, PA
717-949-6817

Shartlesville
MOUNTAIN VIEW SUPPLY, INC.
(Formerly Shartlesville Farm Service)
P.O. Box 529
610-488-1025

Shippensburg
LEINBACH FARM EQUIP.
1120 Ritter Hwy.
717-532-5511

Tamaqua
CHARLES S. SNYDER, INC.
RD 3
717-386-5945

Whiteford MD
ENFIELD EQUIPMENT INC.
720 Wheeler School Rd.
301-879-5090

DISTRIBUTED BY KEYSTONE STIHL