

**1 FARM EQUIPMENT**

**KUBOTA CUTS YOU A DEAL**  
**No payment until April 1, 1996**

**NOW  
20%  
OFF**



- 44" mower deck is easy to adjust and lift
- Foot pedal control hydrostatic for comfortable operation
- Overhead Valve — Air Cooled  
17.0 HP @ 3600 rpm

\*Monthly payments based on 10% down, financing at 7.99% annual percentage rate for 36 months, through Kubota Credit Corporation, on approved credit. No interest until 3/1/96, No payment until 4/1/96. Offer ends 9/30/95.

**Kubota.**  
**STOLTZFUS FARM SERVICE, INC.**  
 Cochranville, PA 19330  
**PH: 610-593-2407**

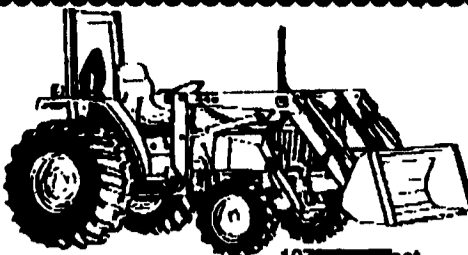

107 SOLD Utility Tractor

**NEW JOHN DEERE COMPACTS**

- Gator 4x2, lift, turf.....\$5,150
- JD 670 w/60 loader..... Cash \$12,495
- JD 870 tractor.....Cash \$13,295
- JD 1070 w/440 loader..... Cash \$19,395

**NEW GEHL EQUIPMENT**

- CB1065 harvester.....\$13,999
- TR3038 row crop head.....\$4,299
- HA1210 7' pickup.....\$3,950
- MF7210 mixer feeder w/scales.....\$10,699
- MF7285 mixer feeder w/scales.....\$13,300

**NEW BRILLION EQUIPMENT**

- PDT14, pulverisor.....\$3,250
- BRS 630 no-till, 6R Cultivator.....\$3,800
- BRS 6302 6R Cultivator.....\$2,275

**USED LAWN & GARDEN**

- JD 430 Diesel w/60" mower.....\$5,795
- JD F935 w/60" mower.....\$4,995

**USED TRACTORS**

- AC model C w/front blade.....\$1,495
- IH 3088.....\$10,500
- Ford 4000.....\$3,900

**USED EQUIPMENT**

- NH 315 w/thrower.....\$2,995
- JD 210 disc harrow.....\$2,685
- JD 3940 Harvester w/5 1/2 pickup..... Call
- IH 440 baler w/thrower.....\$1,295
- Gehl 315 Scavenger.....\$2,495
- Oliver 408 grinder/blower.....\$795
- KW blade, 6', power angle for JD 850.....\$895
- White 543 4R planter.....\$1,295
- IH 1150 grinder/mixer.....\$2,995
- (2) JD F145 5b plow.....\$775/EA
- JD 530 Round Baler.....\$9,900
- Woods 12' Stalk Cutter.....\$2,495
- JD 3R Head.....\$2,675
- Gehl 1250 Harvester, 2 Heads.....\$8,500

**GUTSHALLS, INC.**  
 Carlisle                      Loysville  
 (717) 249-2313      (717) 789-4343

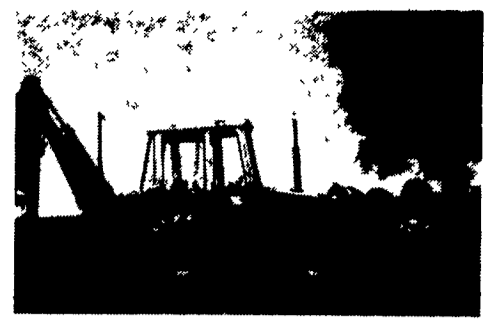

Int. tractor loader backhoe, diesel, full cab, good rubber, overhauled, **\$7,900**  
**717/529-2512 No Sunday Calls**

**NEW EQUIPMENT**

- Sukup 9400 6R Cultivator w/Guidance System
- Agco-Allis 5670 2WD
- Agco-Allis 4650 2WD
- Artway Silamix
- Hydra-Mac 1300 Skid Loader
- M&W Round Baler
- Kidd Bale Chopper
- Marliss No-Till Drill 10' Pull Type
- Landoll 6R Corn Planter
- Landoll 4R Corn Planter
- Wood Mowers
- Deutz-Fahr Hay Equip.
- Kuhn Hay Equip.

Artway  
 Silamix 810  
 Call for super price.

**USED EQUIPMENT**

- 5670 2W Tractor, Low Hours
- AC Model F Combine w/438 C-Head, 13' GH
- Mott 6' Field Mower
- JD Rake w/wheel at tongue
- Deutz DX-130 cab, 2W, excellent condition
- Deutz DX 160, cab, 4W, excellent condition
- N5 Gleaner combine w/630 C-Head, 15' grain head
- 6140 AC tractor w/loader, 850 hours, excellent condition

**B. EQUIP. INC.**

8422 Wayne Highway  
 Waynesboro, Pa. 17268

**717-762-3193**



7AM - 5PM Mon.-Fri.

7:00 AM 3 PM

**GLEANER®**

**HOULE**

**LIQUID  
MANURE SPREADER**

WITH FLOTATION TIRES TO MINIMIZE SOIL COMPACTION  
 Available with complete line of spreading tool bars and precise flow control to spread manure the ecological way eliminating spray drift and reducing odors. Our tool bars are designed to apply hog or dairy manure on growing fields, between rows of corn or on harvested fields.

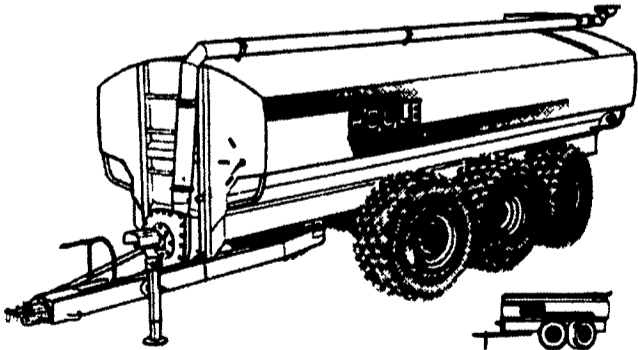

4-6 OR 8 WHEEL SPREADERS WITH POWER STEERING-3850 TO 9500 US GAL.

SPREADERS WITH SINGLE AXLE OR TANDEM-2350 TO 6000 US GAL.

- "V" shape bottom for more complete clean out.
- Standard exterior finish: epoxy primer and urethane paint.
- Low profile tank for maximum visibility and stability.

**Rent the NEW HOULE Steering Axle Spreader**

**AGI-POMPE®**

**AGITATES BOTTOM SEDIMENTS AND SURFACE OF PIT AT THE SAME TIME**

Rotative directional valve designed to be operated while P.T.O. is at low R.P.M.

Powerful nozzle to slice and agitate the crust of manure covering the surface of large holding area.

24" dia. mixing propeller: Providing a full time bottom agitation up to 21 500 US G.P.M. even while loading a spreader.

20" dia. impeller with self-cleaning blades.

Bottom gear box with oil bath protected by a greaseable 3 seals mechanism on each shaft. Available in 5 versions for concrete pits.

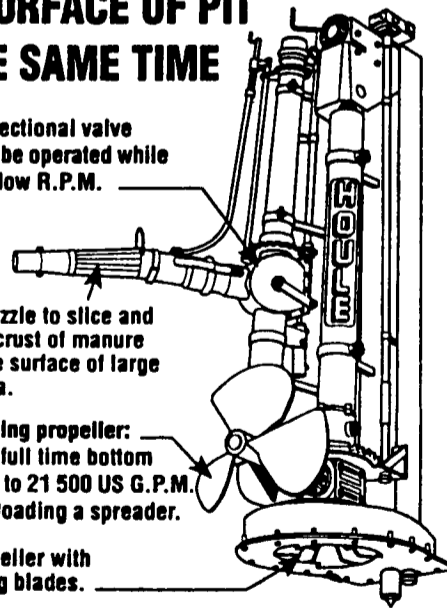

**HOULE Spreaders & Pumps In Stock for Immediate Delivery**

**COWAN EQUIPMENT**

Martinsburg, PA

814-793-4293 Day or Evening or 814-793-9797

Wanted: Fly Wheel & 3 Pt. Hitch Complete For JD 730 Diesel

- JD 5400, 4x4, chopper
- NI 802, 4x4 w/chopper
- NH 1895, 4x4 chopper
- Fox 6250 Chopper, 4x4, corn head & grass pickup
- JD 6600 combine, grain head & corn head
- Gleaner F combine
- NH 1880 chopper
- JD 435 round baler
- JD 2755, 4x4
- JD 2555, cab & air
- JD 2555
- JD 4050, 4 post, quad range
- JD 2950, cab & air, hi-low
- JD 2750, 2WD
- JD 2550, 4x4
- JD 2350, 2WD, 1987 model
- JD 2350, 4x4
- JD 4440, cab & air, power shift
- JD 4440, 4 post, power shift
- JD 2940, cab & air, 4x4
- JD 4630, cab & air, quad range, 4x4
- JD 4430, cab & air, power shift
- JD 2630, hi-low
- JD 4520 w/year-round cab
- JD 4320 w/year-round cab
- JD 4020, '72 model, power shift
- JD 4020, '72 model
- JD 3020, '72 model, powershift, utility
- JD 730, diesel
- JD 620
- JD 520
- JD 450 crawler loader
- IH 1066, fender, black stripe
- IH 1486, cab & air
- IH 574, diesel
- IH MTA w/Wide Front
- Ford TW25, cab & air, 4x4
- Ford 6600
- Oliver 1365, 4x4
- MF 20 industrial w/loader
- NI 325 corn picker, 12 roll bed
- NI 325 corn picker, 8 roll bed
- NI 323 corn picker, 1 row, excellent
- JD 443 corn head
- JD 4 row narrow conversion corn head
- Gleaner 430 corn head
- JD 245 loader
- JD 148 loader, like new
- Axle mount duals for IH 38".....\$650



**Cedar Crest Equipment**

Two Convenient Locations

608 Evergreen Rd.  
 Lebanon, PA 17042  
 (717)270-6600  
 1-800-646-6601

RD 2 Box 271  
 East Earl, PA 17519  
 (717)354-0584