

3 SILOS AND UNLOADERS

FOR SALE

New and Used FICKES SILO

Replace That Old Troublesome Spreader and Pipe with New

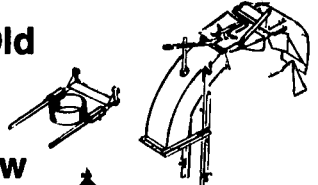
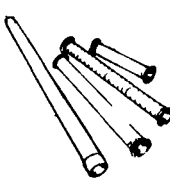

Silo-Matic's GEMINI R/D

Silo Unloader

- Full 26-Inch Stainless Steel Rotor Housing With 4 Stainless Steel Pawls

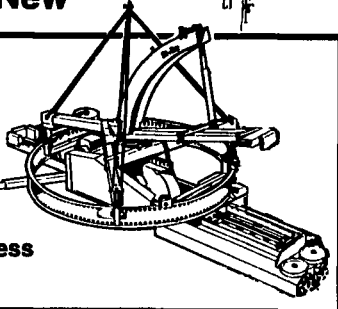

- New Laidig 143-20 Complete.....\$7,000
- 20 Ft. Belt Conveyor (New).....\$1,500
- TMR Mixer 172.....\$5,900
- TMR Mixer 235.....\$6,900

- New and Used Silo Roofs
- Fiberglass and Metal Chutes
- General Repair Work

Sandblast and Gunite - Silo and Barn Wall, Interiors of Silos

FICKES/SILO COMPANY, INC.

Manufacturers & Builders

NEWVILLE, PENNSYLVANIA 17241
717-776-3129 • 1-800-224-SILO

Solid Poured Walls



- Bunker Silos
- Retaining Walls
- Manure Pits
- House Basements 2' to 12' high walls-12" -30" thick

LANCASTER Poured SOLID WALLS

Check your Unloader Cable Check your Tripods



WARNING ALL SILO OWNERS

It's important that you know your silo needs maintenance. Your silo will not fall when it's empty. Please check your silo for damage or check your insurance policy. **Shotcrete is your best, with fiber and retarder for interior work on silo walls - troweled smooth (walls cleaned before coating)**

THIS IS THE BEST HAYLAGE SILO UNLOADER

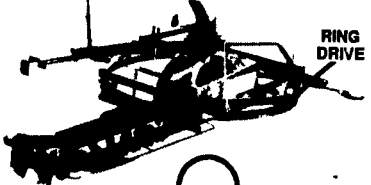

HANSON
There is a difference

BUILT TO LAST PARTS IN STOCK

VAN DALE



PARTS IN STOCK

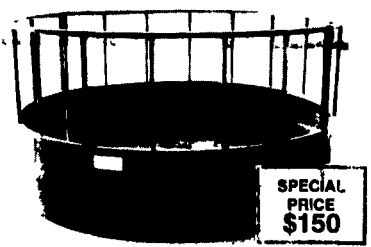

SPECIAL PRICE \$150

Check your field pipe dist. & unloader cable

- Lancaster Belt & Chain Feeders, new & used on hand
- 17x40 Harvestore Silo with Laidig bottom unloader, used 2 yr.....\$4,000
- 20' Ring Drive unloader.....\$2,000
- Approx. 300 Ft. Taper Board Conveyor w/like new chain
- Automatic 200 Rollermill, 6 cut, new rolls.....\$1,500
- Automatic 600 Low Profile 4 Cut, Like New, Will Work in Corn Silage, new rolls.....\$2,400
- Automatic 1200, Earcorn 6 Cut, 1994 model.....\$11,000
- Used 12, 14, 16, 18, 20 ft. Van Dale unloaders

- Case IH 8610 Big Rd. Bale Buster, Like New, Will Tilt.....\$5,500
- VD 2700 Liquid Manure Spreader, Tandem, Like New.....\$3,000
- 3 Row Corn Head with Pickup, Auger Feed to fit NH 900 Series.....\$2,650
- Pickup to fit NH 700 Series, Exc. Cond.....\$600
- NH 315 Baler w/Kawasaki Eng., Rebuilt, Good Cond.....\$5,500
- (4) Rebuilt Blowers, like new.....\$800 ea.
- Used Steiner Mixer.....\$500
- New Knight Mixer.....\$5,000
- Van Dale 300 Cu. Tow Mixer w/Scales, Nice.....\$9,000
- Wic Bedding Chopper, 11 HP Honda, Excellent Condition..\$1,000
- 7000# Zimmerman Tandem Axle Trailer.....\$2,000
- Used 12 x 60 Silo
- Used 14 x 60 Lancaster Silo
- Used 16 x 60 Silo
- Portable fans on stock - 48" - gas or electric

Lancaster Silo Co., Inc.
2008 Horseshoe Rd. • Lancaster, PA • (717) 299-3721 • 800-770-3721

DETWEILER SILOS

New Concrete Stave Silos
New and Used Extensions
All Types Silo Repair
Teardown and Rebuild
Silo Relining



Write or call:

808 Oakville Road, Newville, PA 17241
(717) 532-3039

Goliath 20' silo unloader, 984 hrs., single phase, very very good, \$4,450. 717-249-2317

Harvestore 20x70, nice color, good roof, torn down, \$5,000. 1-800-248-2151

Patz 45' feed conveyor w/ motor, \$1000. 301/582-3872.

Patz 60' shuttle feeder w/ complete 60' feed bunk, nice shape, \$2000. 301/582-3872

WANTED: Concrete stave silos, will remove Fair prices paid. 610-273-3993, 1-800-860-3993.

We pay top dollar for used Harvestores and Slurrystores 717-354-4051

RELINING WITH SHOTCRETE

1/4" shotcrete
Surface is washed with high pressure washer.
Shotcrete is sprayed on and troweled smooth
Proved to be the best product for your silo.
Stops deterioration of staves and strengthens structure.

14 Years Experience Relining Silos

Contact:

Solomon Zook (800) 860-3993 • 610-273-3993
S & S Silo Repair, RD #2, Box 91A Honeybrook, PA 19344

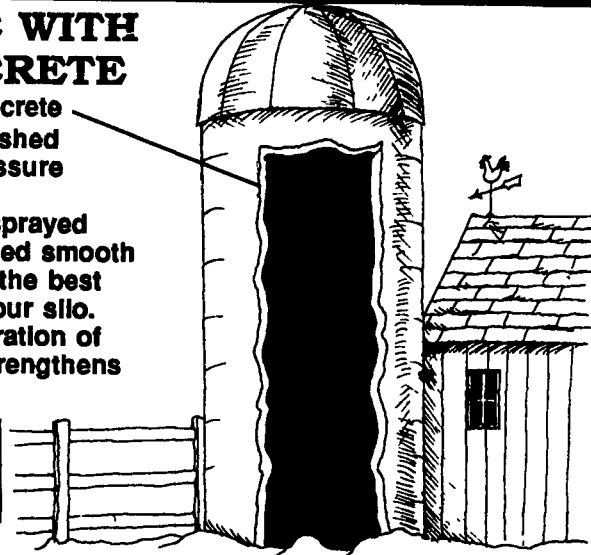

"Aggressive and powerful--98C"

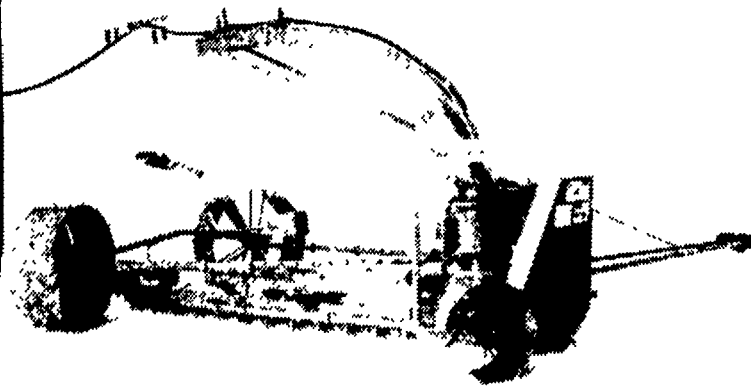

Model 98C Gathering-chain Unloader Increases Blowing Capacity

Big blower handles high volumes.
Four impeller blades adjust for close tolerance and efficient blowing.
Stainless steel blower is available.
Proven cutter-and-claw gathering chain provides high-volume delivery in frozen and hard packed silage.
Fully automatic unloading because the 98C is self-propelled on the silage without cable support. No winch watching!
Depth-of-cut control ensures high-volume delivery.
Automatic self-leveling for uniform silage removal, saving trips up the silo.
All parts go up the chute to install easily anytime.
For 12 to 30 ft. silos.
Patz financing offers affordable rates.
Owners of Patz 61, 66, 98, 98A, and 98B unloaders: This bigger blower will fit your unloader.
Ask for details.

Patz



Cedar Crest Equipment

Two Convenient Locations

608 Evergreen Rd. RD 2 Box 271
Lebanon, PA 17042 East Earl, PA 17519
(717) 270-6600 (717) 354-0584
1-800-646-6601

WE CUSTOM DESIGN SYSTEMS FOR YOU

1a CONSTRUCTION EQUIPMENT

Forklift Wholesalers 2000 to 92000 Lb. Lifts Available. 70 in Stock. Sale-Rental-Finance w/ Warranty. Chalk Equipment. (410)686-6800.

Forklifts, Good selection of used forklifts. 3000# to 8000#. 717-354-3105 Lanco

General trailer B900W, air brakes, \$3,750. Ford 4500 loader, many extras, mint, \$7,500. Davis backhoe 3 point hitch, \$2,500. (908)236-6542

DISTANTLING FOR PARTS. Just arrived for parts IHC 165 crawler loader w/4 in 1 bucket, OR-OPS, fair to good U/C. All parts available BALANDA EQUIPMENT P.O. Box 407 RT 29 Palm, PA 18070 1-800-322-8030

Ingersoll Air Compressor, 40hp w/motor, \$2250 717/354-3105

International loader/backhoe (3444) works everyday, priced \$4900. 717-933-9036

JD 500A rubber tire loader/backhoe, engine just rebuilt, new paint, good condition, w/cab, \$8500 OBO 610/847-8704

DISTANTLING FOR PARTS. Just arrived for parts. Komatsu D31S-15 loader w/OROPS, GP bucket, fair salt tracks, rest of U/C fair. All parts available BALANDA EQUIPMENT P.O. Box 407 RT 29 Palm, PA 18070 1-800-322-8030

Multi-Tech firewood processor, 2040xP cab, heater, elevator, 3200 hrs., \$32,000. 814-634-5242

NH Skid Steer, 1987 diesel, good condition, \$12,500 OBO 908/356-0220 908/996-3034.

Rear steel wheel for Farmall F12. Best offer. (717)568-0767.

Sellick forklift; 74 White truck w/Prentice loader; Franklin skidder; Log-turner; Roto-phase; sawdust blower, loader f/Ford tractor, 318, 350 Detroit motors, Fuller 13 spd transmission; Pete air-ride; 38 Int rear-ends; trailers; electric motors, starters, switches Cearfield. (814)672-3196

SP3030 Ingersoll Rand Vibratory Roller w/Rebuilt Engine, \$8500. All in Working Order. (302)284-4289.

W9 Case rubber tire loader, rebuilt eng., new paint \$14,900; after 6pm 304/274-3665.

WANT TO BUY all makes and models of construction equipment. (301)694-6148. (301)371-9299 fax

3 SILOS AND UNLOADERS

14x70 Fickes Silo; 16' Badger ring drive unloader. S&S Silo; 610/273-3993.

16' Silomatic Silo Unloader, Good Condition. Jonathan Fisher, 1638 Elizabethtown Rd, Elizabethtown, PA 17022 (717)361-0903.

(2) 30'x60' concrete stave silos. (1) 30'x85' concrete stave silo. Midstate Dairy Systems, DeRuyter, NY 13052, (315)852-9591

(3) 20x60 Harvestores, Hercules unloader, 90' bunk feeder 20 farrowing crates (317)583-4164

Buying used stave silos, especially Fickes and Lancaster. Fair price paid. After 6pm, (717)786-2103.

FOR SALE: 1000 Fickes' Silo forms. Price negotiable. 717-776-3129.