

GOING OUT OF BUSINESS SALE

Dresser TD 15, tilt 10 ft. blade,
50,000 lb winch, tracks and
sprocket 90%
\$18,500

Chipper, gas engine, S/N
ED29925
\$3,500

Not Original

Grader, Galion grade-o-matic, 3 axle 12 ft. blade.
Cummins diesel out of frame complete overhaul
Reduced \$6,500 OBO
Jacobsen G10 sickle bar mowing machine, gas, 58
in. sickle bar, runs good, tires good.....\$2,500
Dump trailer 24 ft. parker aluminum
Reduced.....\$6,000

Call Ted (717) 438-3200

1a CONSTRUCTION EQUIPMENT



D6 CAT, Hyd. Blade, Pony
Motor, Good Condition \$3,500
717/859-2792

3 SILOS AND UNLOADERS

**UNADILLA WOOD SILOS
Sales & Service
Leasing Available**

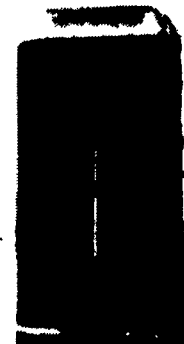

Silo Roofing
Wooden Silo Liners
Distributors and Pipes
Wood Feed Carts
Hay Racks
Silo Homes
Used Silos When Available
12" Goosenecks
Installed On
Sealed Silos

DANIEL S. STOLTZFUS
R.D. 2, Narvon, PA 17555
717-354-4374

**Are You Thinking About
Environmental Safety? You Need To See
Binkley & Hurst Bros. Pressure Washer
Dealer Today!**

**Water Recycling Environmental
Pretreatment Systems
Sales & Service**

From Small To Large
From Portable to Stationary Recycling Systems
Also Available, Portable Collection Pads for Truck Washing Etc.

**You've Asked For It!
It's HERE...**

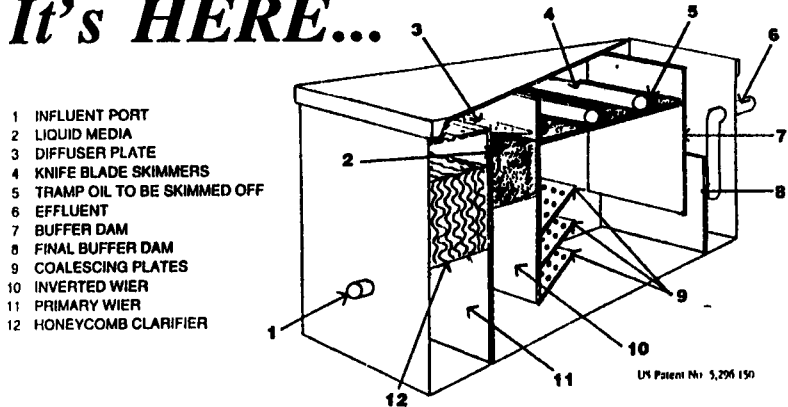

The EPS 500 Liquid Media Separator

1. Flow Rate: Up to 8 G.P.M. (Larger flow rates quoted on request)
 2. Type: Liquid Media Separation with Coalescing and Clarifier Plates
- OPTION
1. Constructed of: 3/4" welded P.V.C. (no rust problems)
 2. Auto controls and pump

Emulsified Oil?

No Problem:

1. EPS 502 Oil Coagulation System
2. OSD - 100 & OSD - 200 Oil Coagulation Chemicals, (non chloride)

For More Information Call:

**Environmental
Pretreatment
Systems**



FUTURA® PRESSURE WASHERS **CAMSPRAY®** PRESSURE WASHERS

From Binkley & Hurst ALSO CUSTOM DESIGNED UNITS AVAILABLE

Call Our Pressure Washer Department Today!

**BINKLEY & HURST
BROS. INC.**

133 Rothsville Station Rd.
P.O. Box 0395
Litz, PA 17543-0395
(717) 624-4705
1-800-487-2978



FOR SALE: CAT D2 S/N
5U5066 w/CAT hydraulic
straight blade, rear PTO,
fair U/C. \$3200.
BALANDA EQUIPMENT
P.O. Box 407 RT 29
Palm, PA 18070.
1-800-322-8030

Case 850 crawler dozer,
6-way blade, good under-
carriage, good condition,
\$8,500. Ditch Witch 3210
trencher. Diesel 6-way
blade, good condition.
Ditch Witch J20 trencher w/
trailer, \$2,900. Promark
bucket lift, 40' reach,
\$6,000. (610)682-4030.

3 SILOS AND UNLOADERS

**MAY-CO PLASTIC
SILO LINERS**

To have mold free haylage, corn silage
& hi-moisture grains; install a May-Co
liner in silos with or without unloaders.
Easy to install.

SHOP (717) 399-8232
OFFICE (717) 768-3269

MAY-CO SUPPLY CO., INC.
48 Jeffrey Road, Gordonville, PA 17529

3 SILOS AND UNLOADERS

JUNE USED EQUIPMENT SALE

SILO UNLOADERS
30' Big Jim Unloader
12' VI Jamesway Unloader
18' Jamesway VII Unloader

BARN CLEANERS
Jamesway 300 Drive Unit
(2) Jamesway 500 Drive Unit
Farmway Drive Unit

FEED MIXERS
115 Oswalt Auger Mixer
(Stationary)
(2) 230 Oswalt Trailer Mixer

SCALE SYSTEMS
6,000lbs Animal Scale System

FEEDERS & CONVEYORS
70' Patz Feeder
45' Belt C **SOLD** Nice
40' Belt Conveyor, Used 4 Years

MANURE EQUIPMENT
8' Jamesway Pit Pump
8', 10' or 12' Jamesway Pit Pump
(elec)
Butler 3300 Gal. Tanker

CIRCULATING FANS
(3) 30" Tube Fans

MISCELLANEOUS
TMR Electric Feed Cart
PTO Bedding Chopper



LAPP'S BARN EQUIPMENT
5935 OLD PHILADELPHIA PIKE, GAP, PA 17527
PHONE: 717-442-8134
SALES & SERVICE



Bunker Silos



Precast Concrete Bunker Silos
or commodity buildings built.
to suit your needs. Bunkers
available in 8 Ft. or 12 Ft. High



477 East Farmersville Rd., New Holland, PA 17557
(717) 355-2361