

HERSHEY EQUIPMENT CO., INC.

Extends

Thanks & Congratulations

STEVE STRICKLAND

Bainbridge, PA - For his decision in choosing



Big Dutchman. AND

"The Mark of Excellence"

HERSHEY

EQUIPMENT CO., INC.

"A Step Ahead"

On his newly remodeled layer house
90,000 birds total capacity

PROFIT-TIER 420

System Features

Big Dutchman has taken its low profile cage and condensed the overall section width to produce the Profit-Tier 420. This four tier system is designed to maximize density in new or existing houses.

The Profit-Tier 420 features the Champion Feeding System with in-line feed hoppers with belts or gear motor drive.

Rigid leg frames with feed trough supports provide suspension and maintain proper alignment for the system.

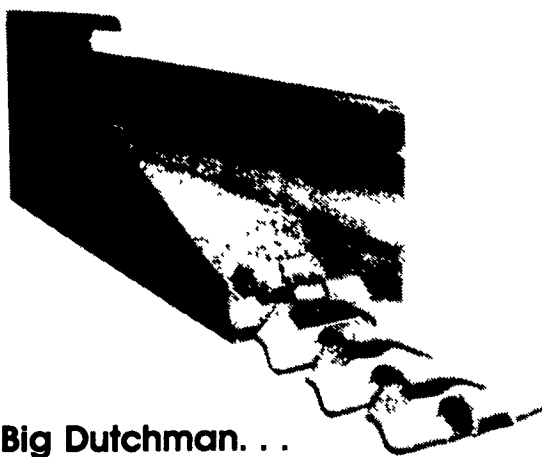
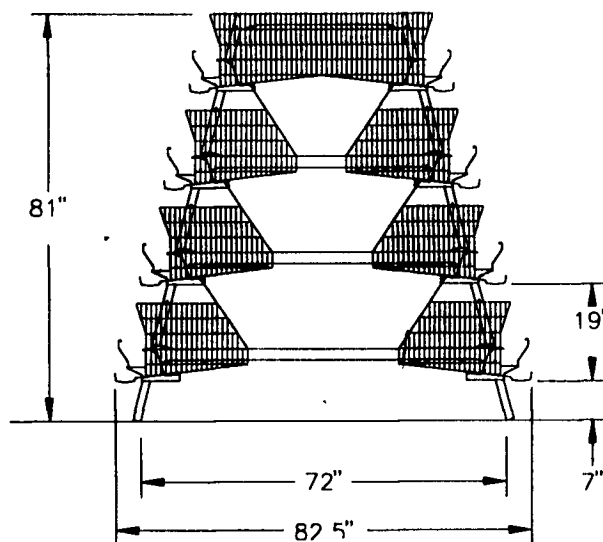

Big Dutchman... The Proven Concept in Automated Feeding

No auger or link feeder can perform as efficiently as the highly successful concept of feeding with a wide chain from a hopper that is open at both ends. It has been proven time and again for over forty years in poultry houses around the world.

OVAL WATERING SYSTEMS



- Drier manure pits and greater freedom from leaks because of the triple seal stainless steel valve seat and low pressure operation.
- Completely enclosed to promote cleanliness and sanitation.

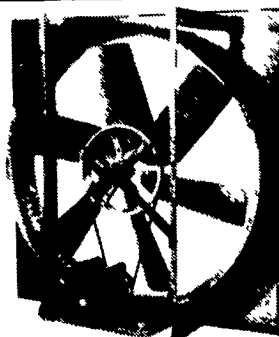
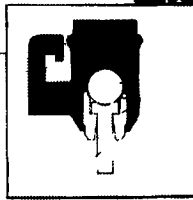

Reliable, Safe Egg Collection and Handling from Cage to Packing Room

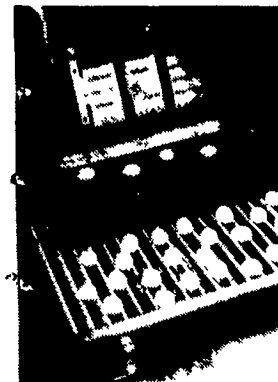

The transfer of eggs from cage belts to cross-conveyor is a critical step in mechanical egg handling. The big Dutchman Fingerbelt collector utilizes a series of rubber fingers mounted in a durable belt to hold eggs in a safe position on the incline, going down from cage belts to cross-conveyor

CONTACT US ABOUT YOUR NEW OR REMODELED POULTRY FACILITY

HERSHEY
EQUIPMENT CO., INC.

SYCAMORE IND. PARK
255 PLANE TREE DRIVE
LANCASTER, PA 17603

(717) 393-5807



Big Dutchman.

"The Mark of Excellence"

IF ITS WORTH YOUR INVESTMENT, TRUST IT TO HERSHEY