

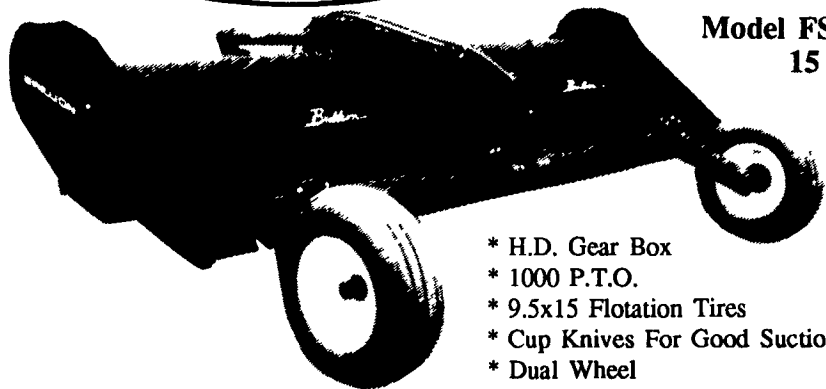

FLAIL SHREDDERS



Model FSC 1806-1
15 Ft.

Reg. \$9,680.00

\$7,350
1 Only

- * H.D. Gear Box
- * 1000 P.T.O.
- * 9.5x15 Flotation Tires
- * Cup Knives For Good Suction
- * Dual Wheel

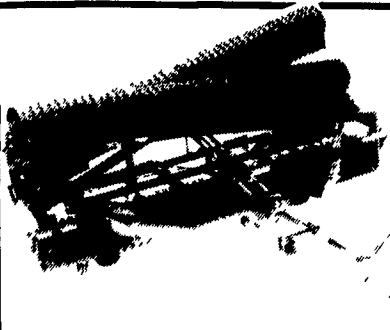

Brillion Hydraulic X Fold Packer SALE The Best Price Is NOW!

Includes:	19 Ft.	\$6,850
* Tandem 9.5Lx15 Flotation Tires	21 Ft.	\$7,385
* Scrapers	23 Ft.	\$7,725
* Cylinders & Hoses	25 Ft.	\$7,998
* Set Up Field Ready		

Brillion BTS-3 Deep Till

- * 3 Auto Reset High Clearance Shanks
- * H..D Help Spring For Rocks
- * Shank Wear Strip

Reg. \$3,450
NOW
1 Only

\$2,685

Kenhar Pallet Fork Quick Attach To Your Bucket 1200 To 11000 Pd. Cap

36" 2500 pd	\$595
42" 4200 pd	\$695
48" 5000 pd	\$850

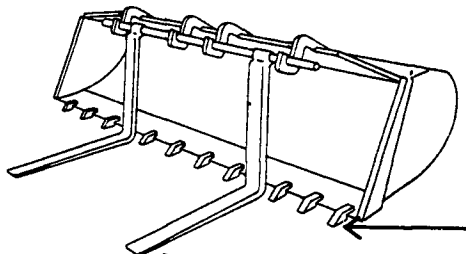

We Stock
Tooth Bars
For Your
Buckets

BEDDING CHOPPER

Model No. BC-30

Farmers
#1 Choice
In Choppers
Reg. \$2,699
NOW

\$2,495

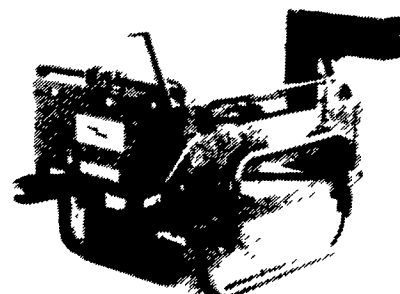

Ideal For Newspaper • Hay • Straw

MISCELLANEOUS SPECIALS

Worksaver LSF-20 (Forged Spear) 2,000 Lb.	\$355
Danuser G20/40 w/12" Auger	\$895
Herd/Thompson Sand/Salt Spreader	Starting At \$495

Westfield Grain Auger 8"x51' P.T.O. w/Transport (In Box)	\$2,195
Walco 3 Pt. Log Splitter (28,000 lb. Splitting Force)	\$725



We've Made A
Commitment To Be
Your Sprayer
Parts Headquarters



20% OFF
All Sprayer
Pumps & Parts!

AG-CHEM 500 GAL. TRAILER SPRAYER



Featuring Hydraulic Fold 47 Foot Torsion Boom.
Electric Controls Tandem Axle Foam marker
1 Only \$7,995

Let Us Help You Customize
Your Sprayer So It's
Just Right For You!!

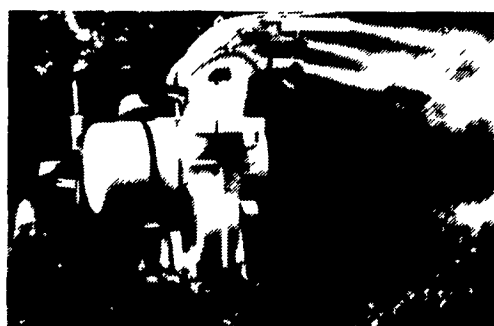

Model 2004 Agtec Air Blast Sprayer

- Low Volume 55 Gal. Cap
- Covers Up 35 Ft.
- Ideal for Vegetables & Orchard

1 Only
Reg. \$5,895

\$4,685⁰⁰

PARMITER

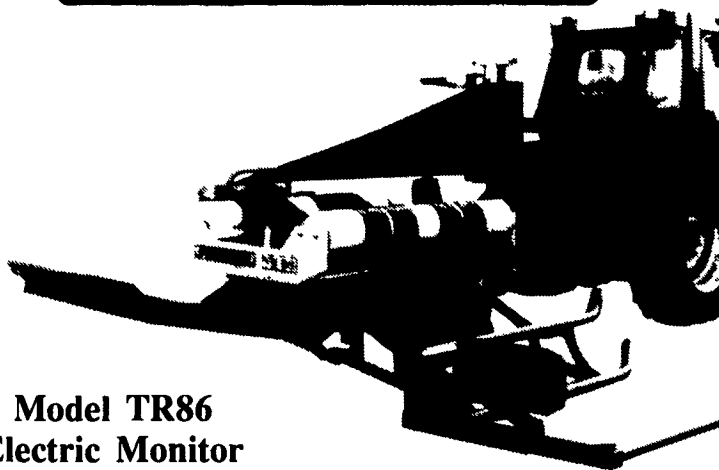

Model TR86 Electric Monitor

• Wraps Bales Fast • Makes Top Quality Haylage
2500 Lb. Bales - 4 Belt H.D. Turn Table
Reg. \$16,895

SAVE \$4,910⁰⁰

Selling Our Demo Unit **\$11,985⁰⁰**

BEDDING CHOPPER

Model No. BC-30

Farmers
#1 Choice
In Choppers
Reg. \$2,699
NOW

\$2,495

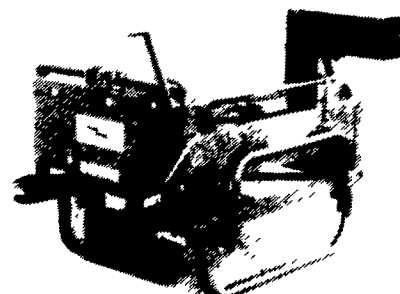

Ideal For Newspaper • Hay • Straw

500 TANDEM AXLE HPT SERIES SPRAYER

from *Demo*



ALL NEW! 45 Ft. Hydraulic Fold Flotation Boom

- 2 1/2 Gallon Clean Water Tank
- Flotation Tires
- Stainless Steel Baffle
- Electric 3-Way Cab Control
- Foam Marker
- PTO Gear Pump
- Stainless Steel Tips

Reg. Sale Price \$10,695.00

**OPEN HOUSE
SPECIAL**

\$8,995
One Only

GLENCOE SOIL SAVER® PARTS

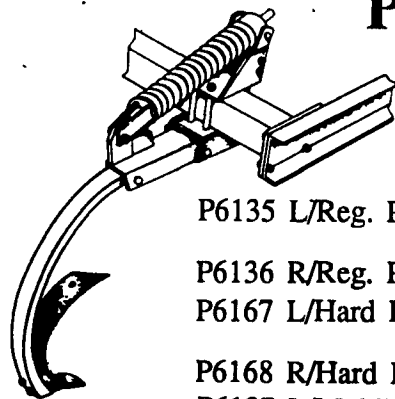

SAVE
OVER
45%

P6135 L/Reg. Point...	\$ 7.92	\$4.45
P6136 R/Reg. Point		
P6167 L/Hard Point...	\$13.20	\$6.99
P6168 R/Hard Point		
P6137 L/Moldboard...	\$12.87	\$6.48

**OPEN
HOUSE
JAN. 23 THRU
JAN. 28**

MESSICK FARM EQUIPMENT, INC.

Farm Equipment Is Our Business
RHEEMS EXIT, RT. 283, ELIZABETHTOWN, PA
Phone (717) 367 1319 653 8867 OR CALL TOLL FREE 1 800 222 3373
We Ship UPS

Special
Events,
Bargains
Galore.