

Leinbach's Shippensburg Produce Auction

(717)532-5511
 Shippensburg, PA
 Average Prices Of #1 Produce
 October 6, 7, 11
 Price Differences are Quality, Size or Days
 Open 10 a.m.
 Report Supplied by Auction
 APPLES: AUTUMN VARIETIES 3.50-9.00 ¼ BU.
 BEANS: GREEN 7.00-9.50 ¼ BU.; LIMA 8.50-11.00 ¼ BU.
 BEETS: 4.00-6.50 ¼ BU.
 BROCCOLI: 4.00-7.00 BU.
 CABBAGE: 3.50-5.50 50 LBS.
 CAULIFLOWER: SMALL TO LARGE: 25-1.00.
 CIDER: 1.65-1.90 GAL.
 CORN: 1.50-1.75 DOZ.
 CUCUMBERS: 3.50-5.00 ¼ BU.
 EGGPLANT: 2.00-4.00 ¼ BU.
 GRAPES: 3.00-5.00 8 QTS.
 PEACHES: 3.00-6.50 ¼ BU.
 PEARS: BARTLETT, DEVOE AND BOSCH 3.00-7.50 ¼ BU.
 PEPPERS: MEDIUM TO LARGE GREEN 5.00-10.00 BU.; RED AND YELLOW MEDIUM TO LARGE 14.00 BU.; HOT 2.00-3.00 ¼ BU.
 POTATOES: RED AND WHITE 3.00-5.00 ¼ BU., 4.00-6.00 50 LBS.; 50 LB. UNCLASSIFIED 3.75-4.50.
 SWEET POTATOES: 4.00-6.75 ¼ BU.
 SQUASH: BUTTERNUT 3.00-5.00 BU.
 MUMS: 6" .60-1.10 EACH, 8" 1.00-2.20 EACH, JUMBO 1.50-3.50 EACH.
 DRIED FLOWERS AND STATICE: 1.50-2.25 BUNCH.

FLOWERING KALE AND CABBAGE: .60-1.60 EACH.
 PUMPKINS: NECK SMALL TO TO LARGE .25-1.75 EACH; FACE SMALL TO LARGE 1.00-3.75 EACH, PRIZE WINNER SMALL TO LARGE 1.00-25.00 EACH.
 SQUASH: BLUE HUBBARD 1.00-2.25 EACH. SUGAR PIE AND PANS .35-.75 EACH.
 GOURDS: 3.00-8.50 ¼ BU.; JACK-BE-LITTLES 5.00-8.00 ¼ BU.; DECORATED GOOSE GOURDS 3.50-7.50 EACH, DECORATE GATOR GOURDS 3.00-7.00 EACH, DECORATED FISH GOURDS 2.00-4.00 EACH, PAINTED PUMPKINS SMALL 1.00-2.25 EACH, PAINTED PUMPKINS LARGE 2.00-19.00; GOOSE GOURDS, FISH GOURDS AND GATOR GOURDS PLAIN SMALL TO LARGE .50-2.00 EACH.
 FALL BASKETS: SMALL AND MEDIUM 3.50-7.00 EACH, LARGE. CORN DOLLS: 3.00-6.00 EACH.
 CORN SHOCKS: .50-1.00 EACH.
 BIRDHOUSE AND DIPPER GOARDS: .35-2.00 SMALL TO LARGE.
 INDIAN CORN: LARGE .75-1.70 BUNCH, DECORATED 2.50-5.25 BUNCH, MINI .35-.90 BUNCH.
 TOMATOES: RED MEDIUM AND LARGE 6.00-12.00 25 LBS.; YELLOW 5.00-9.00 25 LBS., ITALIAN 3.00-5.50 25 LBS.
 TURNIPS: 3.00-5.00 ¼ BU.
 LARGE TREES AND SHRUBS: 8.00-15.00 EACH.
 NEXT WEEK'S SALE DAYS ARE TUESDAY, THURSDAY AND FRIDAY AT 10 A.M.

Kutztown Produce Auction

Fleetwood, PA
 October 7-13
 Sat. Hay and Straw at 9:00 a.m. followed by produce
 Report Supplied by Auction
 APPLES: 2.00-9.50 ¼ BU., 4.50-9.00 BU.
 APPLE CIDER: .70 HALF GAL. 1.30-1.50 GAL.
 BEANS: GREEN 2.50-9.50 ¼ BU.; YELLOW 5.00-10.00 ¼ BU.; LIMA 5.00-7.00 ¼ BU.; BIRDIE 5.00 ¼ BU.
 BROCCOLI: 3.00-6.00 ¼ BU., 2.50-13.00 BU.
 CABBAGE: .40-.90 HEAD, 3.00-5.50 BAG.
 CARROTS: 1.50-3.00 BUNCH.
 CAULIFLOWER: .10-1.60 HEAD.
 CUCUMBERS: 3.50-4.00 ¼ BU., 2.00-5.00 BU.
 EGGPLANT: 2.50-5.50 ¼ BU.
 EGGS: .15-.85 DOZ.
 GARLIC: 1.60 BRAID.
 GOURDS: 1.50-7.00 ¼ BU., 3.00-15.00 BU., .50-1.60 BAG; PAINTED .70-2.00; DRESSED AND DECORATED 3.00-11.00 EACH; BIRDHOUSE .10-3.25.
 GRAPES: 7.00.
 INDIAN CORN: .05-1.40 BUNCH, MINI FINGERS .10-.65 BUNCH; CUTIE BLUES .05-.25 BUNCH; PRETTY PINKS .05-.35 BUNCH; STRAWBERRY POP-CORN .20-.40 BUNCH; YELLOW POP-CORN .10-1.40 BUNCH; COLORED CORN .26-.90 BUNCH.
 NUTS: BLACK WALNUTS .50-11.00 ¼ BU.; CHESTNUTS .70-1.20 LB.
 ONIONS: 3.00-4.00 ¼ BU., 1.40-2.00 10 LBS., 3.00-5.00 20 LBS., 5.00-10.00 50

LBS.
 PEARS: .50-8.50 ¼ BU.
 PEPPERS: 1.50-7.00 ¼ BU., 3.00-8.50 BU.; HOT 2.00-4.00 ¼ BU., .50-1.20 BUNCH.
 PLUMS: 6.50 FLAT.
 POTATOES: 1.00-2.50 ¼ BU., 2.50-7.00 50 LB. WHITE; 2.50-7.50 50 LB. RED.
 PUMPKINS: LARGE FACE .25-2.25, SMALL FACE .14-.80, GIANT 2.50-30.00; PIE PUMPKINS .10-2.50 EACH; NECK .10-2.35 EACH; JACK-BE-LITTLES 3.50-8.25 ¼ BU.; PAINTED .75-1.50 EACH; 10.00-95.00 BY THE BIN.
 RADISHES: 4.00-6.00 ¼ BU.
 RED BEETS: 7.50 BU., 3.00-5.50 ¼ BU.
 SQUASH: WINTER 1.00-9.00 ¼ BU., 3.00-6.50 BU., 40.00 BIN; BUTTERNUT 1.00-4.00 ¼ BU.; ZUCCHINI 7.50-8.00 ¼ BU.
 SWEET CORN: 2.00 BAG.
 SWEET POTATOES: 4.00-8.00.
 TOMATOES: 2.00-18.00 25 LBS.
 TURNIPS: 5.00-11.00 ¼ BU., 10.50-11.00.
 WATERMELON: .70 EACH.
 FLOWERS: CUT .10-25 BUNCH, 6.50 BUCKET.
 HANGING BASKETS: 1.10-3.50 EACH.
 MUMS: .10-1.70 EACH.
 POTTED PLANTS: .40-3.00 EACH.
 CORN SHOCKS: .50-2.10.
 SUNFLOWERS: 1.00 BUNCH.
 SALE DAYS NEXT WEEK ARE TUES. AND THURS. TRUCKLOAD OF PUMPKINS AT 9 A.M., FOLLOWED BY PRODUCE AUCTION. FRIDAY AT 9:30 A.M.
 SHRUBBERY AUCTION WED., OCT. 19, 11 A.M.

GREENS: COLLARDS 4.50-7.00 15 LBS.; KALE 5.50-7.00 15 LB. BOX.
 OKRA: 7.50-10.00 ¼ BU., OTHER 2.10-4.00.
 PEAS: BLACKEYED 6.00 BU.; OTHER 12.00.
 PEPPERS: GREEN MEDIUM 2.50-6.50 1 1/9 BU., LARGE 4.00-6.00; RED 4.50-7.50, ALL 1 1/9 BU.; CHERRY 6.50-7.00 ¼ BU.; HOT CAYENNE 2.50-3.50 ¼ BU.; HOT HUNG WAX 1.25-3.75 ¼ BU.; JALAPENO 1.50-3.00 ¼ BU.; SWEET BANANA 2.00 ¼ BU.; CHILI 2.50 ¼ BU.; HOT ON PLANT 1.00; SPECIALITY OTHER .50-5.50.
 POTATOES: RED 3.50-6.00 BU.; WHITE 1.00 ¼ BU.
 PUMPKINS: BULK SMALL .15-.60, MEDIUM .25-3.25, LARGE 2.00-8.50; MIXED 1.00-2.50; MINIATURE 5.50-11.00 ¼ BU.; HAND PAINTED 1.00-2.75; ORNAMENTAL .20-8.50 ¼ BU., 3.50-6.00 BU.; OTHER .10-15.00.
 RED BEETS: 3.00-3.50.
 SQUASH: PATTY PAN 4.00 ¼ BU.; YELLOW STRAIGHTNECK 7.00-9.00 ¼ BU.; GREEN ZUCCHINI 7.00 ¼ BU.; ACORN 4.00-8.50 1 1/9 BU.; BUTTERNUT 4.00-7.50 1 1/9 BU.; TURKS TURBAN .50-4.50 1 1/9 BU.; WINTER OTHER .40-9.00.
 CORN: BULK 2.50 DOZ.
 SWEET POTATOES: #1 2.50-14.50 BU., #2 1.50-9.50 BU.; JUMBO 2.50-5.00 BU.
 TOMATOES: SMALL 3.50-9.50, MEDIUM 5.00-10.50, LARGE 6.00-11.00; OTHER .80-6.50.
 TURNIPS: .45-1.00.
 APPLES: MIXED SIZES 4.00-7.00 ¼ BU.
 NECTARINES: 7.00.
 PEARS: 3.50-10.00 ¼ BU.
 APPLE CIDER: 1.75 GAL.
 FLOWERING CABBAGE AND KALE: 8" POT 1.00-1.50 EACH.
 FLOWERS: CUT AND DRIED .40-.65.
 INDIAN CORN: .90-1.50 15 BUNCHES; .35-.95 20 BUNCHES; PAPOOSE .80-6.00 20 BUNCHES; OTHER 1.00-1.25.
 MUMS: 6" POT .85-1.25, 8" POT 1.25, 10" POT 1.00-3.75, OTHER 1.00-2.75 EACH.

Buffalo AUCTION & FESTIVAL



HOLLOW HILL FARM
 Paint Bank, VA
 3rd Annual Production Sale
 by Virginia's Largest Buffalo Herd

Saturday, October 22, 1994
 Sale at 1:00 pm

Located at the farm corrals on Rt 600, 2 miles west of Rt 311 at Paint Bank, VA (Paint Bank is scenically located 27 miles south of Covington, VA via Rt 18, or 38 miles West of Roanoke, VA via Rt 311.)

Selling Approximately 65 head of buffalo featuring:
 20 bred 2 year old heifers
 10 yearlings
 25 1994 calves
 5 mature cows
 5 two year old bulls
 Frozen semen will also be available

All females calffhood bangs vaccinated. All buffalo Brucellosis & TB tested to meet or exceed VA requirements. Health Certificates provided.

Terms: Cash or personal checks accepted ONLY IF accompanied by NOTARIZED letter of credit from issuing bank.

Delivery: Day of sale unless other arrangements have been made. No load out until conclusion of sale. Trucking available.

Inspection: 8:00 a.m. - Noon Day of Sale

For more information contact:
 David Sverduk, Farm Manager
 Box 64, Paint Bank, VA 24131
 703/897-5786

BUFFALO FESTIVAL includes:
 Educational Seminars on raising buffalo.
 MAD ANNE RIFLES
 Mountain Man black Powder
 1840 Rendezvous Camp
 Featuring black powder shooting,
 tomahawk and knife throwing.

Native American Dancing and Crafts
 Old Time Band Competition

Spinning, Weaving, Traditional
 Woodworking, Basket Weaving,
 Quilting

Festival begins at 9:00 am
 Admission \$5.00
 Call 703-897-5786



Leesport Farmer's Market, Inc.

Leesport, Pa (610) 926-1307

SPECIAL FEEDER CATTLE SALE

(Approximately 400 Head)

• Consignments Welcome

Refreshments Available

FRIDAY, OCT. 28, 1994

7:30 P.M. Bill Weist

Southern Maryland Regional Farmers' Market

P.O. Box 144, Cheltenham, Md. 20623
 October 3-7, 1994
 BEANS: GREEN 2.00-11.00 BU.; LIMA 8.00-10.50; OTHER 2.00-13.00.
 CUCUMBERS: MED. 6.50-9.00 1 1/9 BU.
 EGGPLANT: 5.50-9.50 1 1/9 BU., OTHER 3.50-6.00.

LIQUID MANURE SPREADER

WITH FLOTATION TIRES TO MINIMIZE SOIL COMPACTION
 Available with complete line of spreading tool bars and precise flow control to spread manure the ecological way eliminating spray drift and reducing odors. Our tool bars are designed to apply hog or dairy manure on growing fields, between rows of corn or on harvested fields.

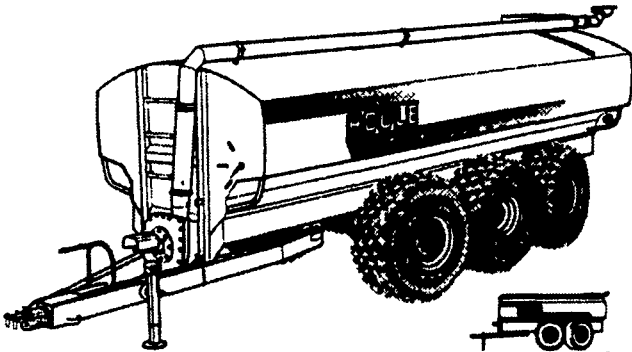

4-6 OR 8 WHEEL SPREADERS WITH POWER STEERING-3850 TO 9500 US GAL.

SPREADERS WITH SINGLE AXLE OR TANDEM-2350 TO 8000 US GAL.

- "V" shape bottom for more complete clean out.
- Low profile tank for maximum visibility and stability.
- Standard exterior finish: epoxy primer and urethane paint.

Rent the **NEW HOULE** Steering Axle Spreader

HOULE

TRAIL

AGI-POMPE

32' and 42' for Lagoons

GREAT PERFORMANCE IN HOG OR DAIRY MANURE

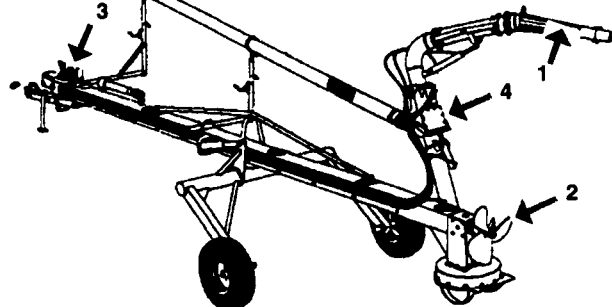

- 1-Highly articulated nozzle designed to slice and break the top crust from above the manure level as the propeller homogenises the liquid with the remaining floating chunks.
- 2-24" dia. mixing propeller providing full time agitation up to 21,500 US G.P.M. even when loading a spreader.
- 3-Hydraulic controls can be operated from tractor seat.
- 4-Rotative directional valve designed to be operated at low R.P.M. without stopping the P.T.O.

Gear box oil bath protected by a greasable 3 seals mechanism on each shaft.

AVAILABLE WITH MULTIPURPOSE OPTION TO ALSO CLIMB INTO CONCRETE PITS UP TO 14' DEEP.

HOULE Spreaders & Pumps In Stock for Immediate Delivery



Cedar Crest Equipment

Two Convenient Locations

608 Evergreen Rd.
 Lebanon, PA 17042
 (717)270-6600
 1-800-646-6601

RD 2 Box 271
 East Earl, PA 17519
 (717)354-0584