

# Ag Secretary Wolff Promotes Pa. Products

CHICAGO — Pennsylvania Agriculture Secretary Boyd E. Wolff met with U.S. Secretary of Agriculture Mike Espy at the Food Marketing Institute/U.S. Food Export Show recently in Chicago.

Espy attended the show at the invitation of the National Association of State Departments of Agriculture (NASDA). He updated delegates about the USDA reorganization, the North American Free Trade Agreement (NAFTA) and the General Agreement on Tariffs and Trade (GATT), and the federal Market Promotion Program.

Buyers from 100 countries attended the FMI/U.S. Food Export Show May 1-4 in Chicago. As a result of NAFTA, there was a

higher level of participation by buyers from Mexico and other Latin American countries.

Wolff led a delegation of 11 Pennsylvania companies that displayed a variety of quality Pennsylvania food products in a special Pennsylvania pavilion that was one of the largest at the show.

Pennsylvania products included ice cream, yogurt, frozen dessert novelties, bottled water, frozen pierogies, chocolate candy, processed meat products, canned vegetables, tomato products, processed dry beans, snack foods, chocolate chips, fruit drink mixes, cocoa powder, sweetened coconut, pancake mix, Belgian waffle mix, gourmet soups, and pet supplies.



From the left, state Secretary of Agriculture Boyd Wolff talks about agricultural products with a products representative, while U.S. Secretary of Agriculture Mike Espy looks over a display. The two met while in Chicago last weekend for the Food Marketing Institute, U.S. Food Export Show.

## CORRECTION

Our story and photo essay last week on the Draft Horse and Mule Progress Days has a wrong phone number to call for information. We apologize for any inconvenience this error may have caused. The correct phone number to call for information about the Draft Horse and Mule Progress Days to be held June 24 and 25 on Elmer Lapp's farm, Kinzers, is (717) 569-7987.

**Patz** - The Only Manufacturer Of Augers And Chain That Feature 5 Silo Unloaders To Fit Your Price And Performance Needs

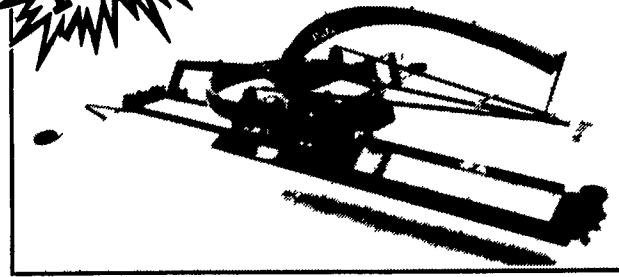

Patz Model 8820 Ring-drive, dual-auger silo unloader

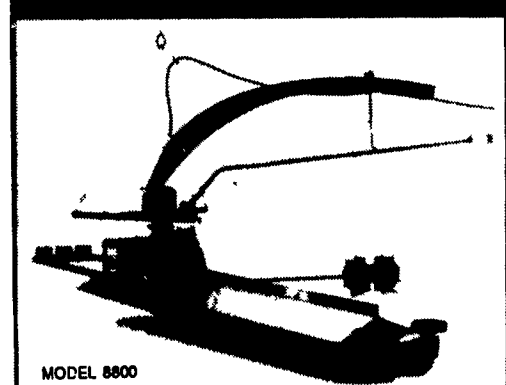

Dual-auger surface-drive silo unloader with Patz quality

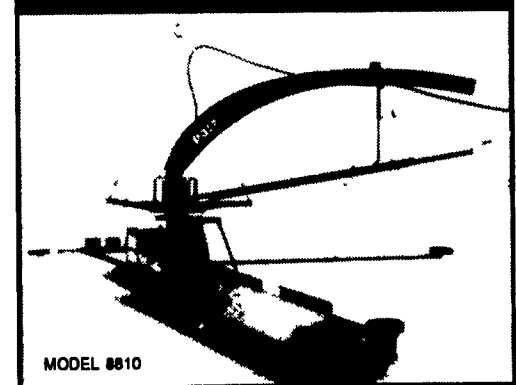

Dual-auger center-drive silo unloader with Patz quality

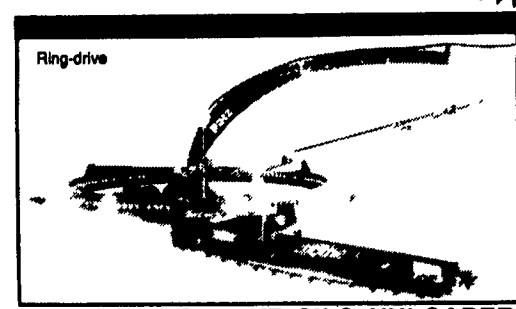

**RD-820 RING-DRIVE SILO UNLOADER**  
Both silo unloaders have a double-hook gathering chain with hardened steel cutters and claws that cut through frozen and packed silage.



**98C SURFACE-DRIVE SILO UNLOADER**

**Silo Unloaders In Stock For Your Haylage Needs!**



**Cedar Crest Equipment**  
Two Convenient Locations

608 Evergreen Rd.  
Lebanon, PA 17042  
(717) 270-6600  
1-800-646-6601

RD 2 Box 271  
East Earl, PA 17519  
(717) 354-0584

**WE CUSTOM DESIGN SYSTEMS FOR YOU**



**SPRING SALE DAYS**  
Save Up To \$200  
On Tillers and Attachments

**QUALITY LAWN & GARDEN CARE**

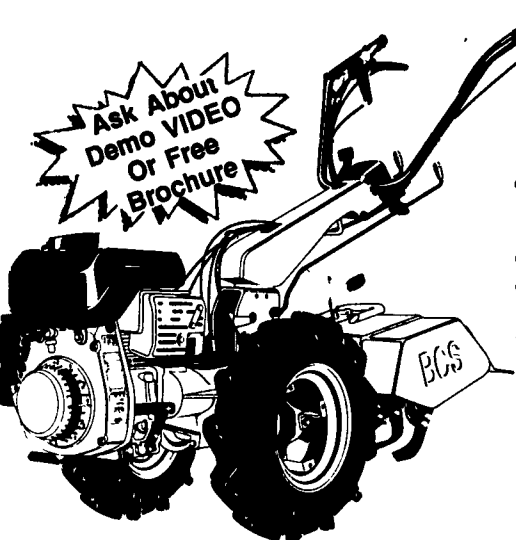

**Compare! Beats The Competition!**

- No-Time-Limit Warranty On All-Gear-Drive Transmission
- No Belts or Chains
- 8 Models From 5 to 14 Horsepower
- Recoil or Electric Start
  - Quick-Change Handle Positions
- 50% Higher Tine Speed Than The Competition
- Adjustable Tiller Width - from 10" - 30"

- Handle Swings 180° To Reverse Direction of Tractor. Just Pull The Pin To Change Attachments In Seconds w/Quick-Hitch Option

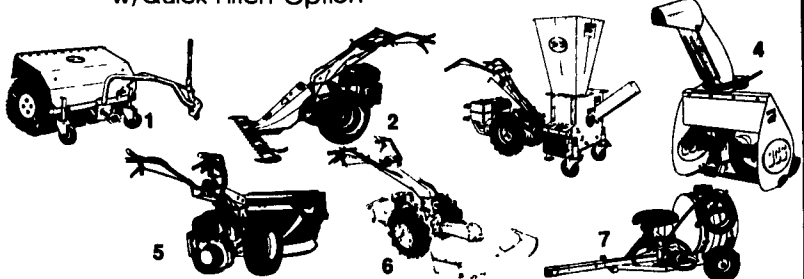

- 1 Power Sweeper
- 2 30"-50" Cutter Bar
- 3 Chipper/Shredder
- 4 Snowblower
- 5 38" Lawn Mower
- 6 30" Brush Mower
- 7 Sprayer

Other Attachments Available

**WES STAUFFER ENGINE**  
Ephrata, PA 17522  
717-738-4215

**STOLTZBUS FARM SERVICE**  
Cochranville, PA 19330  
215-593-2407

**BOB'S OUTDOOR POWER EQUIPMENT**  
Lewisberry, PA 17339  
717-292-3640

**MARTINS HARDWARE**  
Schaefferstown, PA 17088  
717-949-6817

**UMBERGERS of FONTANA**  
Lebanon, PA 17042  
717-867-5161

**LEE'S POWER EQUIP.**  
Berwyn, PA 19312  
610-647-3340