

IH TRACTOR PARTS

Including Crawler & Construction Parts

BATES CORPORATION

14th AND FIR RD., BOURBON, IN 46504

PARTS DISMANTLED, CLEANED & READY FOR SHIPMENT
WE SHIP UPS, TRUCK, BUS

Best Prices On Factory Rebuilt TA's & Clutches
NEW REPLACEMENT PARTS

CALL THE IH PARTS SPECIALISTS
TOLL FREE 1-800-248-2955

JD 5010 150 HP..... \$6,500
JD 5020 170 HP..... \$8,500
JD 4240 1980 \$20,000
JD 4250 MFWD 1984 \$32,000
Several Storage-Road
Trailers..... \$1,500

Ed. Vogt & Son, Inc.
32103 Millington Road
Millington, MD 21651
410-928-3276 Evenings

Best Buys in Used Equipment

USED EQUIPMENT

Farmall 300, gas w/fast hitch
IH 886 w/4 ~~roll~~ guard, good
condition
500 gallon tow type sprayer, 26' boom,
roller pump
6 ton running gear
6' sickle bar mower for Farmall A or
Super A
IH 445 baler w/thrower
(1) NH 489 mower conditioner
Brillion 16' transport harrow

IH model 70 3 btm. pull type plow
IH 435 baler w/thrower
JD 2 row corn head
IH fast hitch equipment: 2 row
cultivator
5' 3 pt. hitch rotary cutter
IH 456 4R Cornplanter, dry fertilizer w/
insecticide

Unverferth gravity boxes in stock

We Ship Parts UPS Daily

BANGOR IMPLEMENT

6 Flicksville Rd., Bangor, PA 18013

215-588-5922 or 215-588-5924



PROTECT YOUR INVESTMENT!

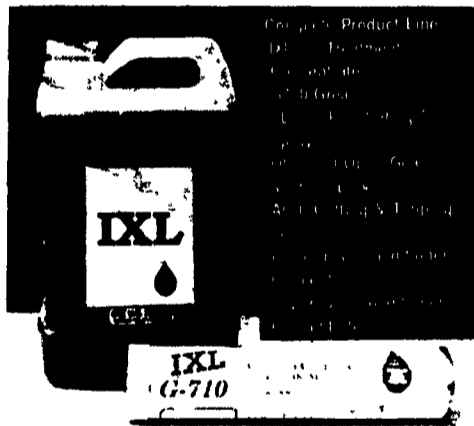

Use IXL In:

- Gas & Diesel Engines
- Motors
- Gear Boxes
- Transfer Cases
- Steering Units
- Universal & CV Joints
- Hydraulic Systems
- Electric Motor Bearings
- Pillow-Block Bearings
- Conveyor Systems
- A/C & Refrigeration System
- Transmissions
- Differentials
- Wheel Bearings
- Compressors

Efficiency
Is Our
Newest
Resource

IXL Technology Is New, Different & Better

Modern lubricants are about as good as they are going to get. So IXL solves the problem of friction and wear by treating the metal itself.

Treated metal parts are smoother, tougher, heat and wear resistant. More importantly, the friction characteristic of the metal itself has been reduced by more than 70%! This allows lubricants to do their jobs better and last longer. Which means your equipment runs better and lasts longer—much longer; as much as two or three times the manufacturer's expected "normal" life!

HOW DOES IXL ANTI-FRICTION METAL TREATMENT ACTUALLY WORK?

Simply stated, IXL is a pressure treatment for steel. Picture iron or steel as a sponge soaking up IXL when heat and pressure are applied for a period of time. IXL is actually attracted to the heat and pressure found in your engine, transmission, differential, wheel bearings and other working parts of your vehicle. The more heat and pressure developed by these parts, the faster and deeper the treatment soaks into them.

Used as directed, the IXL treatment is longlasting and there's no resin coating or bonded film which can peel or rub off; just bare metal with IXL soaked into it. There's no buildup on the metal surfaces and no change of tolerances. The treatment even

remains effective if the metal is heated red hot—way beyond the point where your lubricants have failed.

Friction created by the working parts of your vehicle is always wearing away at the metal surfaces. After treatment with IXL the friction of these surfaces is reduced by 70% or more providing "bare metal" protection and allowing your lubricants to do their jobs much more efficiently. Since friction and wear are a continuous process, we recommend (based on actual use) that you always use a little more IXL when adding or changing oil. As a result, friction and wear are always kept at a minimum. And the metal parts continue to be treated while they do their work.

Dealer Inquiries Invited

Excel Products Company
227 Wood Corner Road • Lititz, PA 17543
Phone: 717/733-6698 • Fax 717/733-0031
800/IXL-LUBE

ATTACHMENTS for Skid Steer Loaders

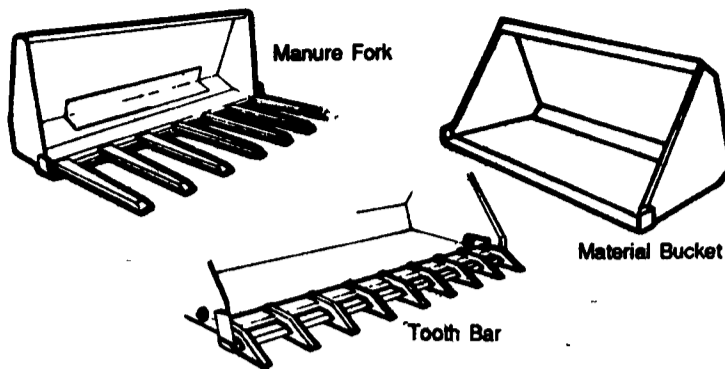

- Standard or Custom Sizes
- Hardened, Beveled Edge
- 7 gauge Material (other gauges available)

Call for a Quote!

PA (717) 354-8721

US (800) 342-0905



CORPORATION

325 West Main St., New Holland, PA 17557

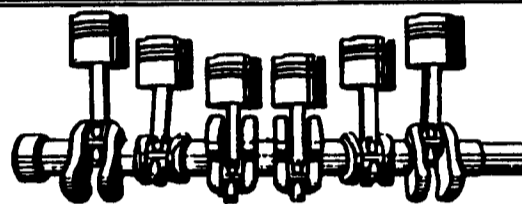

Don't gamble with your modern, high-powered, high priced engine!
When you need engine machine work performed--

We at Rutt's Machine Shop, Inc. have:

- Well maintained, State of the Art, tooling and equipment
 - Length standards traceable to NIST
 - Temperature controlled work environment for accuracy
- All work is done or directly supervised by ASE Certified Technicians
 - 96 years combined experience in our work force
 - Special machining performed by Journeyman Toolmaker
- Large data base of engine specifications (We don't guess)
- Large supply of engine parts available
- Pick-up and delivery service available

COMPLETE

BLOCK-HEAD-CRANK-ROD RECONDITIONING

"Quick Service on Flywheel Grinding"

Call for details (717) 367-3011

RUTT'S MACHINE SHOP, INC.

2329 (Rear) South Market Street
Elizabethtown, PA 17022-9793



We specialize in agricultural and industrial engines

TANEYTOWN FARM & HARDWARE

410-751-1500

Bush Hog® King Cutter
Ingersoll Garden Tractors

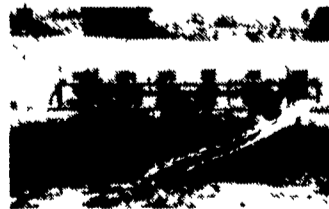

JD 6 row plateless planter
w/Gandy box \$795

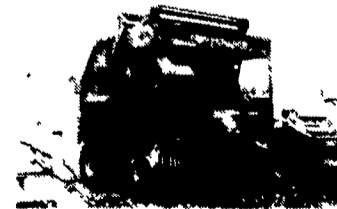

NH 852 Baler w/auto wrap,
excellent condition \$5,400

David Brown 990, 2300 Orig. Hrs. \$4,695
Deutz 6206 4x4 w/loader... \$8,900
Farmall C w/Woods Mower... \$1,995
Ford 6610... \$12,900
(4) 9N Fords... \$1,350 & up
IH 240... \$2,500
MF 135, 2700 hours... \$4,250
MF 275, 1000 hours... \$7,900
MM G450 w/loader, excellent... \$4,900
Oliver 550 w/loader... \$2,950
JD 14T Baler... \$600
JD 24T w/thrower... \$895
NH 68 Baler... \$595
NH 850 round baler... \$1,995
MF 282... \$5,900
New 10' Bush Hog® Mower... \$3,995
New 15' Bush Hog® 2615... \$7,995
Shaver drivers: HD8... \$1,695 HD10... \$1,695
NH 352 grinder mixer... \$1900

Rubber rake teeth \$1.59
20% off list on all Bush Hog® loaders
Call For Prices

CORN PLANTER CLEARANCE SALE

White 5400 4R no till \$950
JD 1460 6R no till \$850
JD 1240 conventional \$495
IH 456 4R conv., excellent \$550
JD 3pt 2R \$395
IH 2R pull type \$350

SPRING ROTARY MOWER SALE

5' 3pt... \$395
6' 3pt... \$695
7' 3pt... \$1,595
5' Finish Mowers \$995