

VAN DALE

WASTE HANDLERS

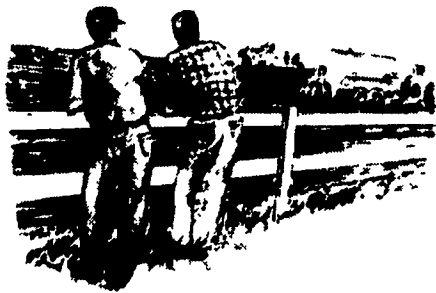

"Charlie sure is gettin' some years outta that tank."
"Not surprising. It's a Van Dale."

When the Going Gets Tough...

VACUUM TANK

CHECK OUT THESE FEATURES

- ✓ Quality Jurup Vacuum Pump—Continuously oiled for long life.
- ✓ Fast Loading—Completed in 3 minutes through 4" or 6" brass side fill valve.
- ✓ Rugged 1/4" Steel Plate Construction—Tank shell, heads and baffles are built of long-lasting 1/4" steel plate.
- ✓ Low, Uniform Spread Pattern—The hydraulically operated rear brass valve unloads manure in a controlled 180 arce up to 30' wide.
- ✓ Adjustable Walking Beam—Can be adjusted forward or back for the right amount of weight on the drawbar hitch.
- ✓ Optional Injectors—Maximize nutrient value with choice of 3, 4 or 5 shank rear-mounted soil injectors.

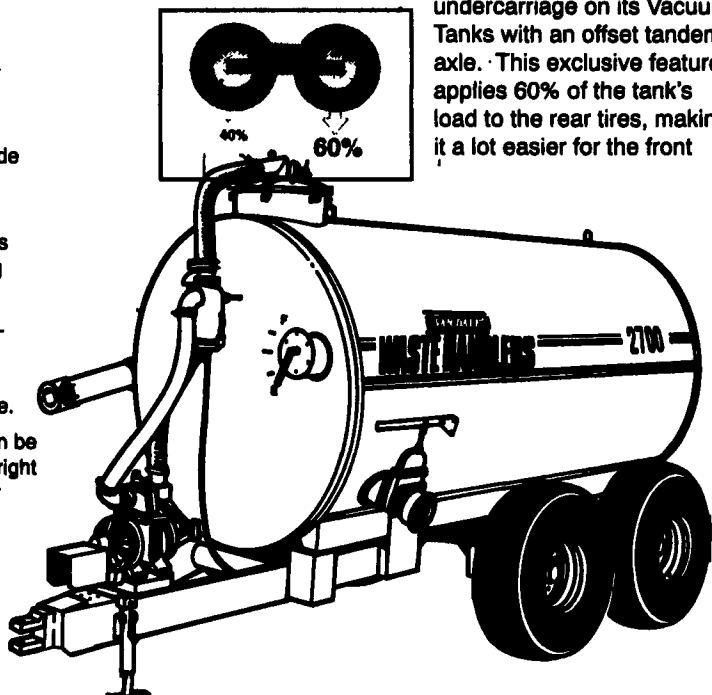

Van Dale redesigned the undercarriage on its Vacuum Tanks with an offset tandem axle. This exclusive feature applies 60% of the tank's load to the rear tires, making it a lot easier for the front

A "New Twist" on Spreading!

SPREADER TANK

CHECK OUT THESE FEATURES

- ✓ Offset Tandem Axle, a Van Dale Exclusive—applies 60% of the tank's load to the rear tires, making it a lot easier for the front
- ✓ Rugged 1/4" Steel Plate Construction—Tank shell, heads and baffles are built of long-lasting 1/4" steel plate.
- ✓ Low, Uniform Spread Pattern—The hydraulically operated rear brass valve unloads manure in a controlled 180 arce up to 30' wide.
- ✓ Adjustable Walking Beam—Can be adjusted forward or back for the right amount of weight on the drawbar hitch.
- ✓ Low Profile, Easy Fill—Fill port is visible from tractor seat and extends into tank to minimize spills.
- ✓ Optional Injectors—Maximize nutrient value with choice of 3, 4 or 5 shank rear-mounted soil injectors.

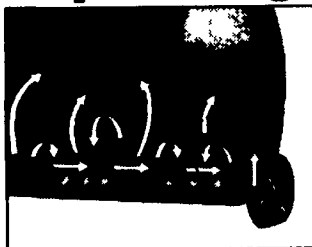

Van Dale Spreader Tanks get the job done better and here's one reason why—its full length, 8" diameter auger. A Van Dale exclusive, the auger provides complete in-tank agitation while hauling and spreading.

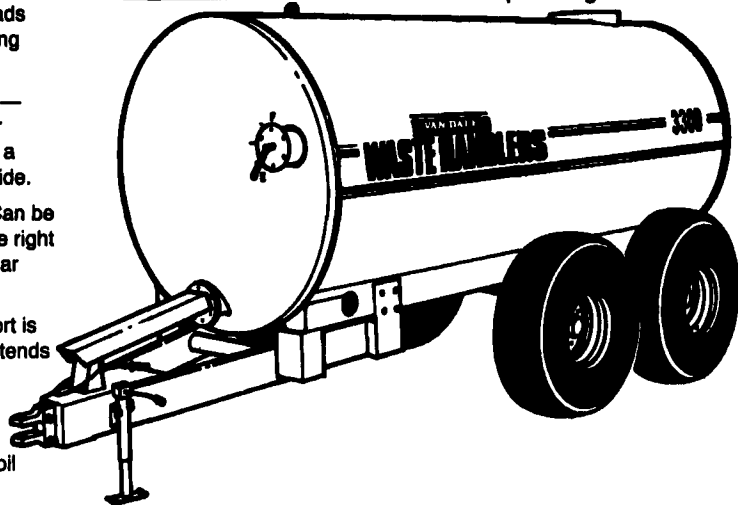

Contact your local dealer for details!

VAN DALE WASTE HANDLERS

K & S INC.
 Quarryville, PA
 717-284-3111

RYDER SUPPLY CO.
 Chambersburg, PA
 717-263-9199

McMILLEN BROTHERS
 Loysville, PA
 717-789-3961

STAR SILOS
 Myerstown, PA
 717-866-5708

MILL CREEK FENCE & FARM
 Lancaster, PA
 717-396-8987

Carlisle Livestock Market

Carlisle, Pa.

Tuesday, April 26, 1994

Report Supplied by Auction

SLAUGHTER: STEERS SELECT 900-1100 LBS. 66.00-68.75; SELECT LIGHTS 60.00-65.00; HOLSTEINS SELECT AND CHOICE 60.50-63.25; STANDARD 900-1100 LBS. 53.25-57.00. SLAUGHTER COWS: BREAKING UTILITY AND COMMERCIAL 46.00-50.00; CUTTER AND BONING UTILITY 45.50-49.50; HIGH DRESSING TO 53.00; CANNER AND LOW CUTTER 40.00-45.00; BIG MIDDLE 43.00-45.50; SHELLY 39.00 DOWN.

SLAUGHTER BULLS: YG#1 58.00-63.50; YG#2 57.00 AND DOWN. FEEDER CATTLE: FEEDER STEERS 200-300 LBS. 115.00-122.50, 400-600 LBS. 85.00-100.00; 650-850 LBS. 71.00-76.00; HOLSTEINS 67.00-83.00; FEEDER HEIFERS 200-300 LBS. 107.50-117.50; 400-600 LBS. 76.0-88.00; HOLSTEINS 69.00-75.00; DAIRY TYPES 52.00-63.00; FEEDER BULLS 200-400 LBS. 83.00-99.00; 450-650 LBS. 65.00-78.00; 700-850 LBS. 53.00-65.50; HOLSTEINS 60.00-74.00.

CALVES: VEALERS CHOICE 97.00-115.00; CALVES RETURNING TO THE FARM, STRONG DEMAND! HOLSTEIN BULLS #1 90-135 LBS. 150.00-175.00; HOLSTEIN BULLS #2 70-130 LBS. 110.00-147.00; HOLSTEIN HEIFERS #1 75-140 LBS. 180.00-225.00; BEEF X BULLS 95-110 LBS. 150.00-165.00.

SWINE: HOGS US#1-3 220-270 LBS. 40.00-42.00; 275-360 LBS. 40.00-47.00; 190-210 LBS. 38.50-39.25; US#2-4 325-400 LBS. 32.00-34.75; 220-270 LBS. 39.00-39.85; SOWS US#1-3 350-450 LBS. 36.25-37.25; US#2&3 350-480 LBS. 34.00-36.00; FEEDER PIGS BY THE HEAD, STRONG DEMAND. 15-25 LBS. 20.00-32.00.

GOATS: BY THE HEAD, FANCY KIDS 42.50-60.00; FLESHY KIDS 30.00-41.00; SMALL KIDS 15.00-28.00. LAMBS: SELECT AND CHOICE 20-35 LBS. 90.00-125.00; SELECT AND CHOICE 40-60 LBS. 75.00-88.00; SELECT AND CHOICE 65-90 LBS. 67.00-77.50; MEDIUM, ALL WEIGHTS, 65.00-87.50.

SHEEP: ALL WEIGHTS 18.00-44.00. SALE EVERY TUES. LIVESTOCK 7 P.M. RABBITS, POULTRY AND EGGS 5:55 P.M. RECEIVING 4 P.M.

Morrison Cove Livestock Auction

Martinsburg, Pa.

Monday, April 25, 1994

Report Supplied by Auction

CATTLE: 274. STEERS: CHOICE 71.50-75.75, GOOD 70.50-71.50. HEIFERS: CHOICE 71.00-73.75, GOOD 69.00-70.75. COWS: UTILITY & COMMERCIAL 45.50-52.00; CANNER

AND LOW CUTTER 37.50-45.50. BULLOCKS: GOOD & CHOICE 60.50-64.00.

BULLS: YIELD GRADE NO. 1 57.50-63.00.

FEEDER CATTLE: STEERS 72.00-101.00, BULLS 70.00-88.00, HEIFERS 64.00-81.00.

CALVES: 137. PRIME, NO MARKET TEST, CHOICE, NO MARKET TEST, GOOD 86.00-98.00, STANDARD 40.00-75.00, HOLSTEIN BULLS 90-130 LBS. 110.00-152.00, HOLSTEIN HEIFERS 90-130 LBS. 150.00-230.00.

HOGS: 187. US NO. 1-2 41.00-42.00, US NO. 1-3 39.50-40.50.

SOWS: US NO. 1-3 32.00-40.00.

BOARS 29.00-32.00.

FEEDER PIGS: 34 HEAD. US#1-3 20-50 LBS. 15.00-31.00.

SHEEP: 52. CHOICE LAMBS 75.00-90.00, GOOD LAMBS 65.00-73.00, SLAUGHTER EWES 19.00-30.00, GOATS 15.00-71.00.

18 LOADS OF HAY. ALFALFA 61.00-101.00; TIMOTHY 60.00-78.00; 1 LOAD OF STRAW, 72.00; 1 LOAD OF EAR CORN AT 85.00.

Lebanon Valley Livestock

Fredericksburg, PA

Tuesday, April 26, 1994

Report supplied by Auction

CALVES: 102 HEAD. VEAL CALVES 120-215 LBS. 65.00-81.00; GOOD AND STANDARD 75-100 LBS. 45.00-55.50; UTILITIES 45-70 LBS. 35.00-46.50; #1 FARM BULL CALVES 90-115 LBS. 150.00-165.00; #2 90-110 LBS. 140.00-150.00; #1 HEIFER CALVES 90-120 LBS. 200.00-220.00; #2 85-115 LBS. 140.00-150.00.

STEERS: 18 HEAD. CHOICE 1010-1310 LBS. 69.00-72.50; SELECT 1260-1300 LBS. 66.75-68.75; STANDARD 1375-1410 LBS. 63.75; HOLSTEIN STEERS CHOICE 1265-1335 LBS. 63.25-64.75; SELECT 1305-1435 LBS. 62.25-63.25; STANDARD 1055-1125 LBS. 54.25-56.75; HEIFERS, 1 CHOICE HOLSTEIN 1080 LBS. 62.35; SELECT 1065-1155 LBS. 53.00-57.50.

COWS: 105 HEAD. BREAKING UTILITY 48.50-52.75; HIGH YIELDING 53.25; CUTTERS AND BONING UTILITIES 45.00-49.00; CANNERS AND LOW CUTTERS 42.00-45.00; SHELLS DOWN TO 36.00.

BULLS: 7 HEAD. YG#1 1710-1960 LBS. 58.00-60.50; YG#2 1315-1710 LBS. 52.75-55.50.

FEEDER CATTLE: 9 HEAD. 4 HEAD AT 460 LBS. 79.50; 5 AT 500 LBS. 66.50. HOGS: 129 HEAD. #1&2 221-260 LBS. 41.00 AND 41.60; #2&3 205-230 LBS. 36.75-38.50; 265-295 LBS. 35.00-36.50.

SOWS: 30 HEAD. 500-595 LBS. 38.50-42.00; #2&3 320-420 LBS. 33.75-36.50.

BOARS: 13 HEAD. 460-600 LBS. 30.50-31.25.

LAMBS: 40 HEAD. 90-100 LBS. 50.00; 30-50 LBS. 75.00-102.00; SLAUGHTER SHEEP 15.00-26.00.

DRAINAGE PROBLEMS?

Cocalico Equipment Specializes in Drainage Work



Whether your problem is subsurface water or surface water—Contact Us. We will be glad to give you some suggestions on what to do with your particular problem. We also work very closely with the SCS in your county.

Homeowners!
 Do You Have A Wet Basement - We Can Help - Give Us A Call

We Install Ponds:

- New Pond Construction
- Reconstruction of Existing Ponds
- Seal Leaking Ponds

• FREE ESTIMATES •

- We Sell Pipe - All Kinds - All Sizes -



COCALICO EQUIPMENT CO.

Farm Drainage & Excavating
 323 Reinholds Rd. Denver, PA 17517
 (717) 336-3808 (717) 738-3794



VAN DALE®

Dependability through Quality