

THE VAN DALE ADVANTAGE

**AT THE
PA STATE
FARM
SHOW**

MAIN FLOOR

#21 thru 23
45 thru 42

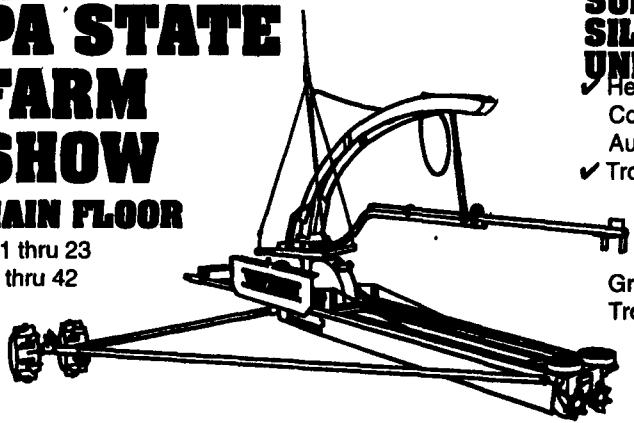

SURFACE DRIVE SILO UNLOADERS

- ✓ Heavy-Duty Counter-Rotating Auger System
- ✓ Trouble-Free Gearbox
- ✓ Collector Ring with Six Metal Graphite Brushes for Trouble-Free Electrical Connections
- ✓ Remote Electrical Control

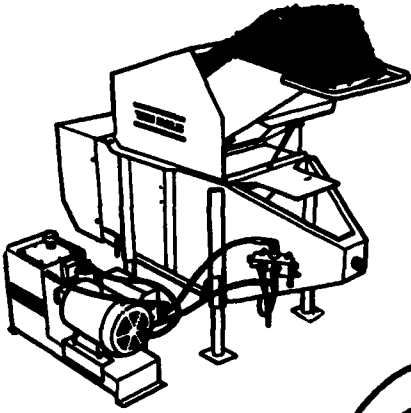

BALE PROCESSOR

- ✓ Works With All Mixer Types
- ✓ Hay Breaks Down Quickly
- ✓ Eliminates Splintered Hay Stems, Increases Dry Matter Intake
- ✓ Optional 3-Point Hitch; 5' Discharge Chute

ORBIT II MIXER

- ✓ Hydraulic Drive
- ✓ Flow Control Valve
- ✓ Planetary Power Hub
- ✓ Simple to Operate Electronic Scale
- ✓ EZ210 Indicator with Scrolling Messages

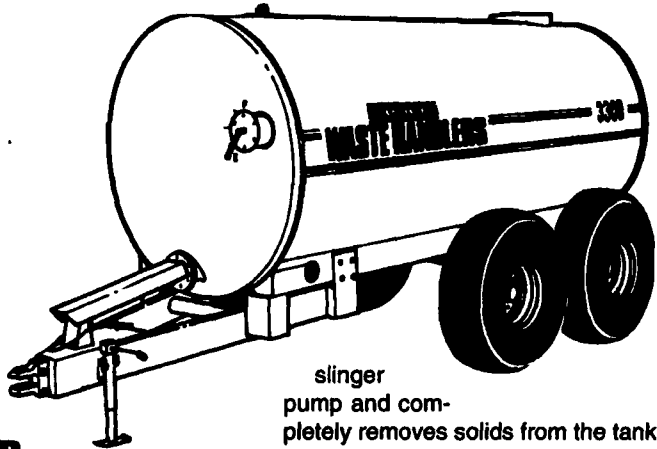
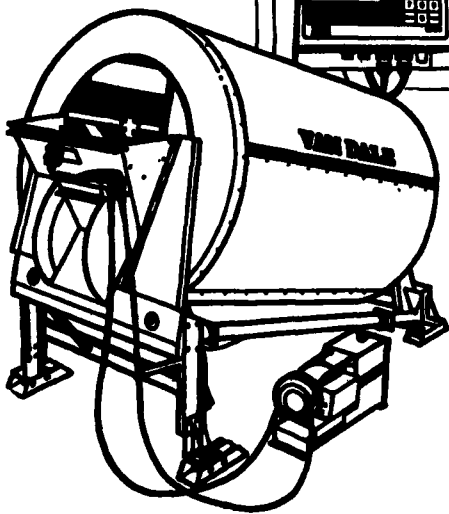

SPREADER TANK

Van Dale Spreader Tanks get the job done better and here's one reason why—its full length, 8" diameter auger. A Van Dale exclusive, the auger provides complete in-tank agitation, evenly feeds manure to the rear

slinger pump and completely removes solids from the tank. If this feature doesn't convince you Van Dale tanks are better, its comprehensive warranty* will—10 pro rated years on the tank body, and 5 years on the undercarriage. So put a new spin on the job with Van Dale's exclusive auger, and get it done.

VAN DALE®

Dependability through Quality

FRANKLIN'S FARM SERVICE

Laceyville, PA 717-869-2407

STAR SILOS

Myerstown, PA 717-866-5708

McMILLEN BROTHERS

Loysville, PA 717-789-3961

K & S INC.

Quarryville, PA 717-284-3111

LANCASTER SILO CO, INC.

Lancaster, PA 717-299-3721

HISTAND'S FARM & HOME SERVICE

Rome, PA 717-744-2371

PAUL JACKSON'S LIVESTOCK SYSTEMS

Troy, PA 717-297-3872

RYDER SUPPLY CO.

Chambersburg, PA 717-263-9199

MILL CREEK FENCE & FARM*

Lancaster, PA 717-396-8987

* Mixers, Spreader Tanks and Bale Processors Only

3 SILOS AND UNLOADERS

20x60 Lancaster Silo w/ very good Patz 98B unloader. S&S Silo, (215)273-3993.

(2) 20x80 Madison silos, like new condition, \$2000/each. 410/778-6008.

Fiberglass Bulk
Feed Bins



Lancaster Farming, Friday, January 7, 1994-D65

ZOOK'S

SILO REPAIR

Buy And Sell Silos
General Repair Work
Extensions, Roof Repair,
Chute Repair, Tear Down &
Rebuild. Reline With Shotcrete
Distributors, Fill Pipe

RD 2, Box 90
Honey Brook, PA 19344

(215) 273-9211

BADGER'S AGRI SERVICE, INC.

Dillsburg, PA 15 miles South of Harrisburg

717-432-8377 Brian Badger

STOP IN AND SEE
US AT THE
FARM SHOW FOR
ALL YOUR
HARVESTORE®
NEEDS

MAIN BUILDING
37, 38, 39, 24, 25, 26

Highest Quality Replacement
Parts And Service

Not affiliated with A.O. Smith
Harvestore Products, Inc.

TRAK STARS



Feed-Trak™

High-Capacity Belt Feeder

It's hard to imagine so much feeder at such a good price. Let your Starline Dealer show you why Feed-Trak is so efficient, dependable and quiet. New feeder features simple design, exclusive smooth-running track and trolley system and high capacity STARglider™ V Plow. This feeder is right on "trak"!

Cen-Trak™

Power Drive Unloader

Meet Cen-Trak! The new and better concept in single-cable unloaders. Simple, dependable power drive design eliminates the problems of other high-torque, center-drive machines. You get economy and faster, high-capacity unloading with fewer trips up the silo. Only from Starline!



Built to last, priced to sell.

SPECIAL! - J-Star Replacement Augers For Van Dale

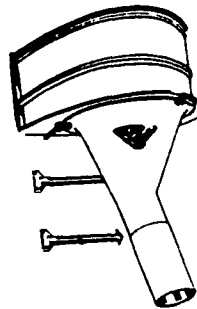

Fiberglass
FIBERGLASS
FUNNEL
\$165.00

FOR SALE:
135 Rissler Mixer
Like New

Full Line
Parts
Department
For Starline

SEE US AT THE PA FARM SHOW
ON DISPLAY: Feed Trak, Cen-Trak, Rollermill



DONALD R. NISSLEY

RD #1, Willow Street, PA
(Corner of Rt. 272 S. & Byerland Church Rd.)

(717) 786-7654