

3 SILOS AND UNLOADERS

MARTIN'S SILO REPAIR

Moving Concrete Stave Silos

- Gunite Relining
- Fill Pipes
- Distributors
- Roofs
- Replacement Doors
- General Repair

907 Centerville Rd.
New Holland, PA 17557
(215) 445-9834

\$\$ SAVE DOLLARS \$\$

Corrugated Grain Storage Silos Various Sizes - 10 Cents/Bushel (20,000 Bushels Costs \$2000) You Unbolt & Haul.

Call Mr. Lane
215-853-3969

ATTENTION FARMERS!

Plan Now For Your Storage Needs In 1993. Used Harvestores® & Slurrystores® In Stock - Ready For Another Season. NEW ERECTION KITS and Quality Structures Guaranteed. We Emphasize Quality!

So Check With Us NOW & SAVE.

- * New Power Sweep Auger Unloaders
- * New Goliath II - In Stock
- * New Aluminum Access Doors - **-\$150.00**
- * REXNORD Chains, Sprockets, Etc.
- * Rebuilt Goliath & Hercules Unloaders
- * Any Replacement Parts -Herc. or Gol.
- * Epoxy Floors
- * Lancaster LEVEL-FLO Goosenecks

REXNORD CHAINS
\$725 - Goliath 20'



"Used Harvestores®" is our Business Since 1975

Better Bilt Storage, Inc.

Rt. 2, Sugarcreek, Ohio 44681
216-852-4088

Not affiliated with A.O. Smith Harvestore Products, Inc.

RISSLER FORAGE BLENDERS
FOR YOUR TOTAL MIXED RATION REQUIREMENTS

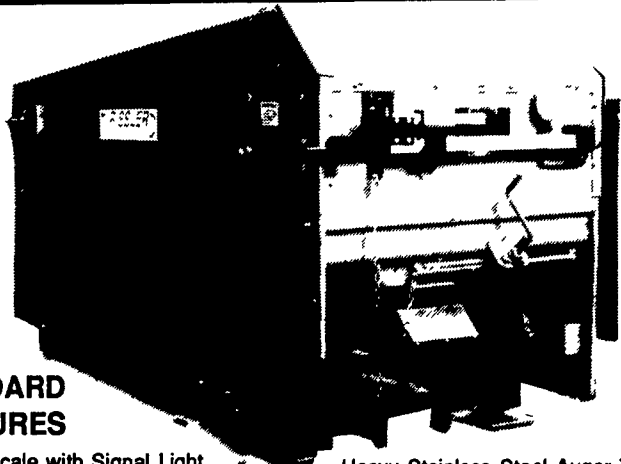

STANDARD FEATURES

- Beam Scale with Signal Light
- Motors Included with Price
- Fast 2-5 Minute Mix Time
- Stainless Steel Floor
- Heavy Stainless Steel Auger Trough
- Lower Energy Consumption
- Discharge Chute with Magnet

OPTIONS AVAILABLE

- Wall Mount Beam Scales with Cable & Pulleys
- 90° Crank on Discharge Door
- Motorized Discharge Door
- Beam Scales Mounted On Either Side
- Electronic 110 Volt Beeper
- Electronic Scales with or without Memory
- Truck or Trailer Mount with Side Discharge

FIBERGLASS FUNNEL

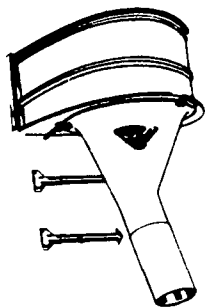

\$165.00

SPRING SPECIAL
SAVE \$500
LIMITED TIME

The Center Of Attention



Cen-Trak

Power Drive Unloader

Full Line Parts Department For Starline



DONALD R. NISSLEY

RD #1, Willow Street, PA
(Corner of Rt. 272 S. & Byerland Church Rd.)
(717) 786-7654

Agripac™

THE SILAGE SOLUTION



Celebrating Our 10th Anniversary

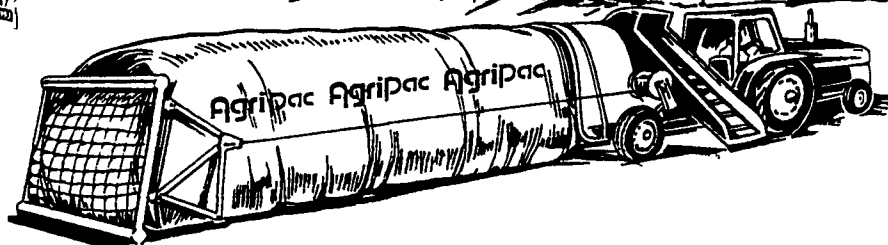

SILAGE BAGS & BAGGERS

- Triex Bonded Bags- White & Black
- Single ply white 7', 8', 9', 10', 11' & 12' bags; length available 100'-275'. Available w/24 month, 12 mo., & 90 day warranty.
- Folded Tubular Bale Bags- 4, 5 & 6' Up To 200 Ft. Long
- Trench & Pit Covers

SPRING SPECIAL PRICING AVAILABLE NOW ON BAGS & BAGGERS

- 7 Ft. Baby Bagger
- 8 Ft. Husky Bagger
- 8, 9, 10' Senator Bagger w/Feeder Table
- Grain Bagger w/Transfer Auger
- High Moisture Corn Bagger w/Transfer Auger 8, 9 & 10'

DEALER INQUIRIES WELCOME

For More Information Call:

Toll Free 1-800-661-4150
(717) 656-4578 • (717) 656-9919

P.O. Box 430, Brownstown, PA 17508 - Lancaster County

Patz® - The Only Manufacturer Of Augers And Chain That Feature 5 Silo Unloaders To Fit Your Price And Performance Needs

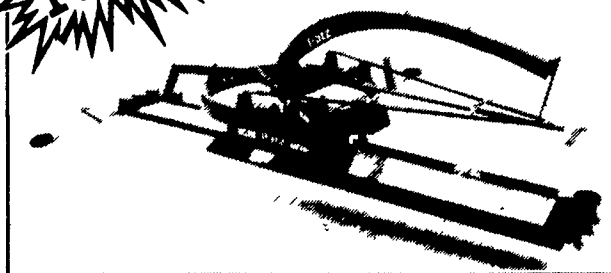

Patz Model 8820
Ring-drive, dual-auger silo unloader

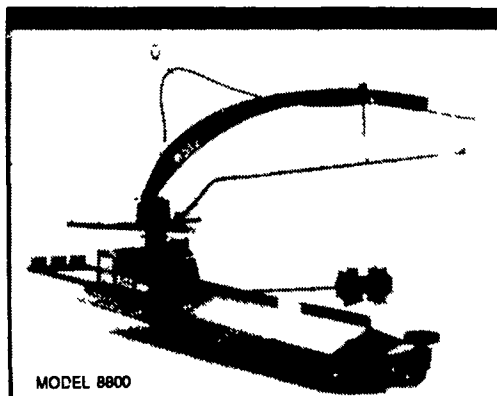

MODEL 8800

Dual-auger surface-drive silo unloader with Patz quality

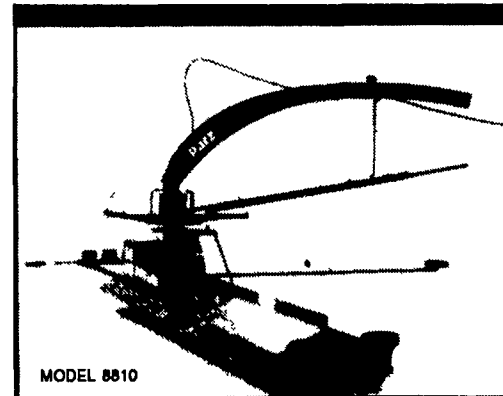

MODEL 8810

Dual-auger center-drive silo unloader with Patz quality

AFFORDABLE FINANCING

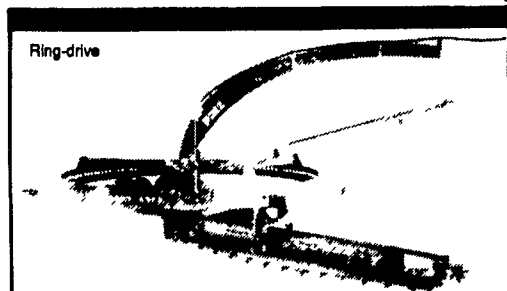

RD-820 RING-DRIVE SILO UNLOADER
Both silo unloaders have a double-hook gathering chain with hardened steel cutters and claws that cut through frozen and packed silage.



98C SURFACE-DRIVE SILO UNLOADER

SILO UNLOADERS IN STOCK



Cedar Crest Equipment

Two Convenient Locations

608 Evergreen Rd.
Lebanon, PA 17042
(717) 270-6600

RD 2 Box 271
East Earl, PA 17519
(717) 354-0584

WE CUSTOM DESIGN SYSTEMS FOR YOU