

**The
4ORCE!**

- For...
 • Ventilation • Conveying
 • Feeding • Pumps
 • Tankers • Silo Unloaders

"BARNSTORMER"

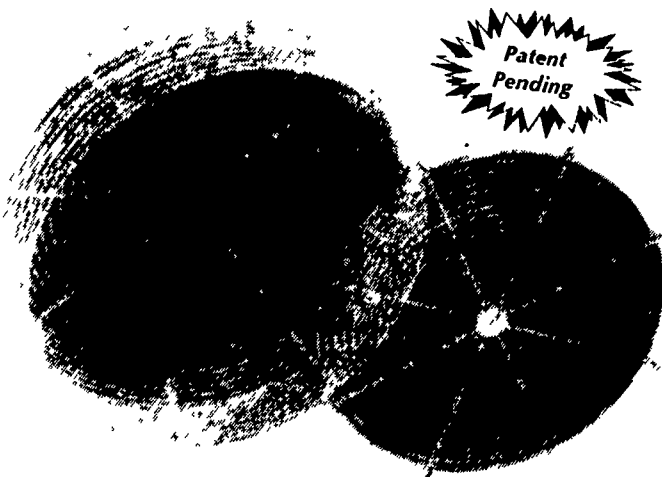

**Exclusive
Open
Front**

Hinged Front simply unhooks and pulls open for easy access. Special Patented Design allows more air flow and a much wider air pattern.

NEW DESIGN FOR "93"

**J&D
Manufacturing**

MORE DISPERSEMENT AND SAFETY

**Experience can't
be imitated...
quality can't be
copied...Hanson
can't be beat!**

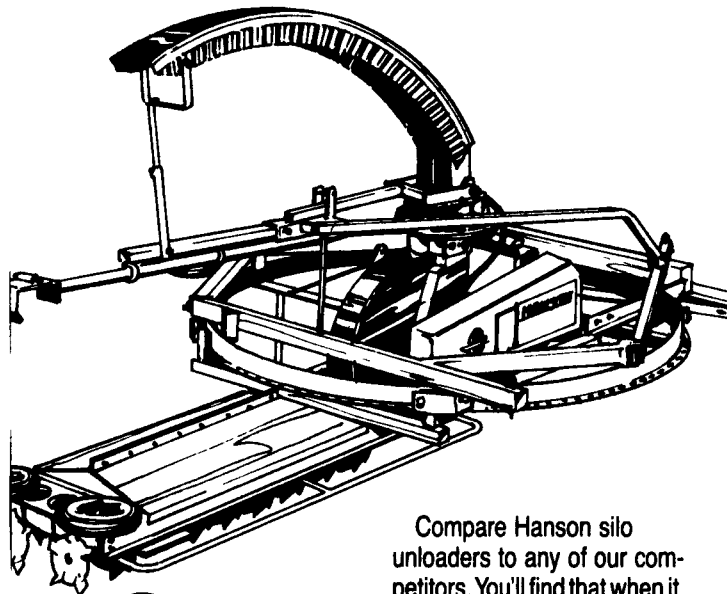

Compare Hanson silo unloaders to any of our competitors. You'll find that when it comes to value, there's no competition. Hanson. There really *is* a difference.



Piston Pumps

Vertical Electric Pumps

Vertical PTO Pumps

Check the

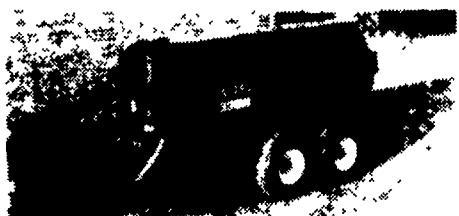

Trail'r Type Lagoon Pumps

Prop Agitators

3 Point Hitch Pumps

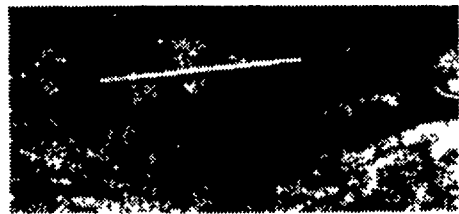

High Pressure Manure Irrigation Pumps

Hydraulic Submersible Pumps



Side Mount Pumps

Slurry Tankers

Vacuum Tankers

Replacement Parts and Rebuilds for Nesselth, Badger and Butler Pumps

Check with your **N-TECH Dealer** for the most complete line of high quality, performance-proven liquid manure equipment available.

NTH, Inc. Barron, Wisconsin 54812 (715) 537-9207

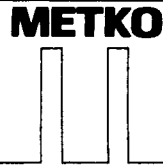

**CONVEYING — FEEDING
EQUIPMENT SPECIALISTS**



**A TMR MIXER
WITH A "REEL DIFFERENCE"**

**METKO
1560
POWER-
BLEND®
TMR MIXER**

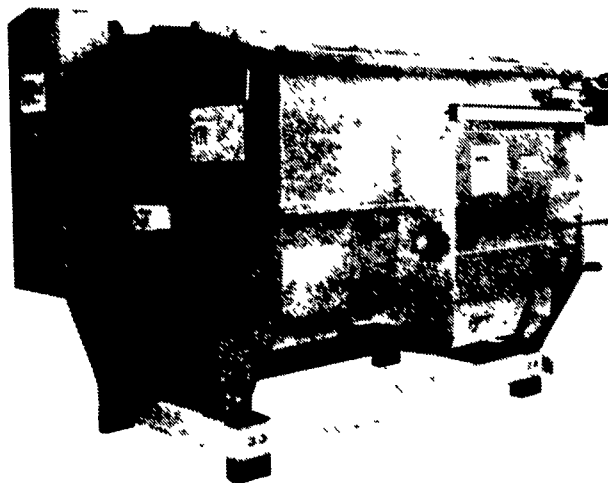
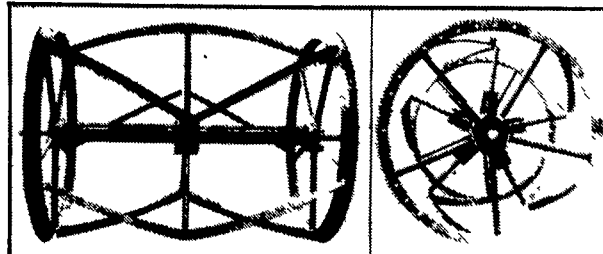

METKO 1560 BUILT FOR TODAY... AND TOMORROW

4 COMPANIES PROVIDING YOU THE BEST PRODUCTS AVAILABLE!

**THE
4ORCE**

HANSON • J&D MANUFACTURING • METKO • N-TECH

**DEALERS THROUGHOUT PA, VA, MD, W.V.
LOCAL WAREHOUSE # 301-223-5151**

8 AM to 5 PM M-F

CALL FOR THE DEALER NEAREST YOU

or

**CONTACT: KRIS KNUDSEN AREA MANAGER
717-653-0385 FAX 717-653-0243**