

Estimated Daily Livestock Slaughter

Under Federal Inspection

July 29, 1992

	CATTLE	CALVES	HOGS	SHEEP
WEDNESDAY (EST)	121,000	5,000	325,000	19,000
WEEK AGO (EST)	118,000	5,000	350,000	19,000
YEAR AGO (ACT)	121,000	6,000	291,000	17,000
WEEK TO DATE (EST)	338,000	16,000	951,000	55,000
SAME PD LT WK (EST)	350,000	14,000	961,000	54,000
SAME PD LT YR (ACT)	344,000	16,000	839,000	55,000

PREVIOUS DAY ESTIMATED TUESDAY STEER AND HEIFER 95,000; COW AND BULL 22,000.

Central U.S. Carlot

Beef Report
July 29, 1992

Report supplied by USDA

CENTRAL U.S. CARLOT BEEF REPORT (INCLUDES THE MAJOR PRODUCTION AREAS IN THE MIDWEST AND TEXAS) AS OF 3 P.M. COMPARED TO WEDNESDAY'S 3 P.M. REPORT: UTILITY CARCASSES GENERALLY STEADY TO FIRM; CUTTER NOT ESTABLISHED. DEMAND AND OFFERINGS LIGHT.

COW AND BULL CARCASSES
FOB OMAHA BASIS
10 LOADS REPORTED
UT, BRK 2-4, 45Q & UP, 3 LOADS, RANGE 81.00-83.00, LATEST ESTB. MKT. 81.00-83.00.

UT, BNG 1-3, 400 & UP, 7 LOADS, RANGE 85.00-87.50, LATEST ESTB. MKT. 85.00-87.50.

CUTTER 1-2 350 & UP, LATEST ESTB. MKT. 93.00 B
BULLS 500/UP, YG 1, LATEST ESTB. MKT. 100.00 A.

BONELESS PROCESSING BEEF/ BEEF TRIMMINGS
135 LOADS, REPORTED
FRESH 90% BONELESS BEEF IN

THE MIDWEST, FIRM TO 2.00 HIGHER, AND IN TEXAS, FIRM TO 1.00 HIGHER; 65% 1.00 HIGHER THAN LAST TEST. DEMAND AND OFFERINGS LIGHT TO MODERATE; MOVEMENT SLOW. BEEF TRIMMINGS MOSTLY STEADY ON LIGHT TO MODERATE DEMAND AND OFFERINGS ON REPORTED SALES.

FOB OMAHA BASIS
90% FRESH, 29 LOADS, RANGE 115.0-117.0, WT. AVG. 116.22.
90% FZ, UNQUOTED.
85% FRESH, RANGE 109.00, WT. AVG. 109.00 E.
85% FZ, 75% FR AND 75% FZ, UNQUOTED
65% FRESH, 4 LOADS, RANGE 73.0, WT. AVG. 73.00.
65% FZ, UNQUOTED.

50% FR, 72 LOADS, RANGE 53.00-54.00, WT. AVG. 53.33.
50% FZ, 3 LOADS, RANGE 54.50, WT. AVG. 54.50.

50% BX, UNQUOTED.
BULL 92-94, RANGE 145.00, WT. ASVG 145.00 A

FOB EAST TX AND OK:
90% FR, 16 LOADS, RANGE 116.5-118.0, WT. AVG. 116.97.
90% FZ, 85% FR, 85% FZ UNQUOTED.

75% FR, 4 LOADS, RANGE 89.5-90.0, WT. AVG. 89.75.

75% FZ, 65% FR AND 65% FZ, AND BULL 92-94 UNQUOTED.

CAF NORTHEAST AREAS:

90% FR, 5 LOADS, RANGE 117.0, WT. AVG. 117.00.

90% FZ, UNQUOTED.

85% FR, 2 LOADS, RANGE 109.0, WT. AVG. 109.00.

85% FZ, 75% FR, 75% FZ, 65% FR, 65% FZ, UNQUOTED.

**ABCDE AFTER QUOTES REPRESENTS DAYS SINCE LAST ACTUAWL MARKET TEST. QUOTES ARE DROPPED AFTER 5 DAYS OF NO TEST OR BEFORE IF THEY NO LONGER REFLECT CURRENT MARKET CONDITIONS **

Oklahoma City Feeder Cattle

Oklahoma City

Wednesday July 29, 1992

Compared with last week: Feeder cattle and calves steady to \$2.00 lower; feeder market improved towards steady side since noon Monday. Initial demand light for all classes but improved considerably to moderate to good as cattle futures more optimistic than expected following last Friday's C.O.F. report. Weigh conditions uneven gaunt to full. Flesh condition of feeders attractive, average to slightly thin. Quality of supply not as good as past few weeks, plain to average with modest end attractive.

Pasture conditions remain excellent throughout this trade territory with good thundershower activity. Slaughter cows steady to \$1.00 lower, Utilities at full decline. Slaughter bulls steady. Demand moderate for slaughter cattle. Receipts this week 7,660; last week 12,224; last year 7,846. Supply consisted of 73% yearlings over 600 lbs.; 21% calves; 6% cows and bulls. Bulk prices follow; weighted average prices in parenthesis:

Feeder Steers: Medium and Large Frame 1, 375-400 lbs. \$101.00-\$107.75;

400-500 lbs. \$92.00-\$105.00 (\$98.22);
500-600 lbs. \$86.25-\$94.75 (\$91.76);
600-700 lbs. \$83.00-\$89.75 (\$86.45);
700-800 lbs. \$80.00-\$84.50 (\$82.64);
800-850 lbs. \$79.00-\$83.25 (\$81.07);
850-900 lbs. \$77.00-\$81.50 (\$78.29);
900-950 lbs. \$74.00-\$78.00 (\$76.00).
Large Frame 2 Holsteins, 315 lbs. \$98.75;
375-400 lbs. \$87.00-\$91.00; 450-500 lbs. \$81.00; 500-525 lbs. \$76.00-\$77.50;
575-700 lbs. \$70.25-\$73.25; 700-825 lbs. \$66.50-\$69.25; 925 lbs. \$64.00; 1050-1125 lbs. \$60.25-\$61.75.

Feeder Heifers: Medium and Large Frame 1, 350-400 lbs. \$94.00-\$99.00 (\$95.82); 400-500 lbs. \$86.00-\$92.50 (\$90.09); 500-600 lbs. \$82.00-\$88.25 (\$85.45); 600-650 lbs. \$80.50-\$85.00 (\$83.02); 650-700 lbs. \$79.75-\$82.50 (\$81.05); 700-800 lbs. \$76.75-\$80.00 (\$79.09); 800-850 lbs. \$74.25-\$76.75 (\$75.17).

Slaughter Cows: Cutter, Boning and Breaking Utility Y.G. 1-4 average dressing \$46.50-\$49.50; high dressing \$49.25-\$54.50.

Slaughter Bulls: Y.G. 1 1300-2100 lbs. average dressing few \$60.00-\$60.75; high dressing \$61.00-\$64.50.

Winchester, Va. Horse Sale

Report Supplied by Auction
July 24, 1992

77 HEAD.
RIDING HORSES: AVERAGE TO GOOD QUALITY 3-12 YEARS, GRADES AND REGISTERED 900-1150 LBS. 580.00-810.00; 800-900 LBS. 390.00-505.00.

BETTER QUALITY 3-11 YEARS REGISTERED AND GRADES 950-1100 LBS. FEW 900.00-1275.00.

LOOSE HORSES: AVERAGE TO GOOD FLESH 900-1100 LBS. 465.00-630.00; 800-900 LBS. 365.00-440.00.

Kutztown Produce Auction

Fleetwood, PA

July 24-30, 1992

9:30 A.M. Mon.-Sat.

Report Supplied by Auction

CABBAGE: 30-40 HEAD.
CANTALOUPE: 40-1.00 EACH.
CUCUMBERS: 2.00-5.50 1/4 BU., 4.50-7.50 BU.
PEPPERS: 5.00-8.00 1/4 BU.
POTATOES: 3.00-5.00 1/4 BU.
RASPBERRIES: RED 10.00-16.00 FLAT.

BLUEBERRIES: 13.00-15.00 FLAT.
RED BEETS: WITH TOPS 3.00-4.00 1/4 BU.

SQUASH: YELLOW 2.00-5.00 1/4 BU., GREEN 3.00-5.00 1/4 BU.

BEANS: GREEN 3.00-6.00 4 BU., YELLOW 4.00-7.00 1/4 BU.

CORN: 1.25-2.50 DOZ.
EGGPLANTS: 12.50 BU.

LIMA BEANS: 14.00-19.00 1/4 BU.
GROUND CHERRIES: 10.00 FLAT.

TOMATOES: 7.00-32.00 25 LBS.;
CHERRY 6.50-8.50 FLAT.

WATERMELON: 1.60-2.60 EACH.
APPLES: LODI 3.00-6.00 1/4 BU.

PEACHES: WHITE 10.50-13.50 1/4 BU., YELLOW 4.00-9.00 1/4 BU.

PLUMS: 7.00-9.00 1/4 BU.
NECTARINES: 8.00-14.00 1/4 BU.

GARLIC: 1.25-1.90 LB.
PLUMS: 9.00-11.00 1/4 BU.

FRUIT AND VEGETABLE AUCTION
MONDAY-SATURDAY AT 9:30 A.M.



CLASSIFIEDS



"BELT BUSTERS"

Save on Flat Belts for Your Farm Machinery! We Will Make the Belt You Need and Ship Same Day by U.P.S. - We're Fast!

- ★ Bale Thrower Belts
- ★ Round Baler
- ★ Harvesting Machines Like Bean, Cherry, Grape, Etc.
- ★ Forage Box Belts for Gehl, Grove Kasten, New Idea, Etc.

Quality Belts at Farmer Prices

SORRY, NO V-BELTS

Agricultural Belt Service

10632 Rt. 75
Eden, New York 14057
PHONE 716-337-BELT

CALF KENNELS



Also Available: Calf Hutches And Bulk Plywood
Feed Bins, Horse, Sheep & Hog Shelters
LOCUST POST & FENCE BOARDS

MFD. BY: STOLTZFUS WOODWORK

Rt. 897 North - Gap, PA 17527
717-442-8972



DYNA-TECH INDUSTRIES
602 E. EVERGREEN ROAD
LEBANON, PA 17042-7925

SERVICE OUR FIRST CONSIDERATION

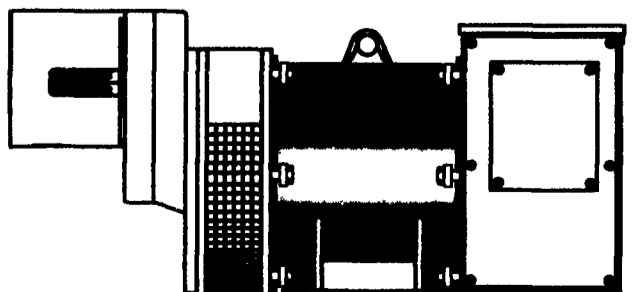

10 TO 150 KW 1800 RPM BRUSHLESS
TRACTOR DRIVEN GENERATORS

DISTRIBUTOR FOR



GENERATOR SYSTEMS

5 to 1628 KW

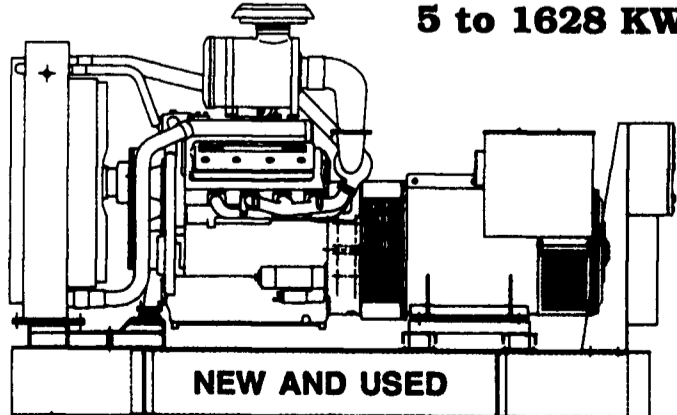

NEW AND USED
SALES - SERVICE - RENTALS
INSTALLATION
UPS, UBS AND SURGE PROTECTION

800-779-8809
717-274-8899
FAX 717-274-5334

SCHAEFER
Ventilation Equipment

BarnKooler
Air Circulation Fan

The Schaefer Barn Kooler® is the only patented air circulation fan on the market today! (U.S. Patent # 4,818,183) Because of its design, it provides more air movement and therefore, more cooling effect than any other circulation fan.

* Available in 20" (6000 CFM) and 24" (8500 CFM)

Ask for the Schaefer Barn Kooler®

Leid Farm Supply
201 Gristmill Rd.
New Holland, PA 17557

(717) 355-0441
Amm - Clay - Varian - Matlin