

See Us July 14 & 15 At The Lebanon Fair Grounds

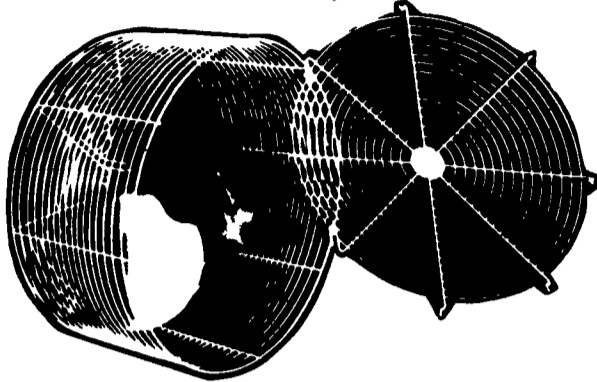

**"BARNSTORMER"**  
NOW WITH NEW EXCLUSIVE SWING AWAY FRONT  
THE NEW REVOLUTIONARY "BARNSTORMER" FAN  
PULLS OPEN FOR EASY ACCESS.



JUST SNAPS SHUT  
(NO TOOLS REQUIRED).

**"NEW"**  
UP TO  
11,200 CFM

12" • 20" • 24" • 36"

Custom Designed Ventilation  
Systems For Your Barn...

CALL TODAY!

**J&D**  
**Manufacturing**

**N-TECH '90s SLURRY TANKER**

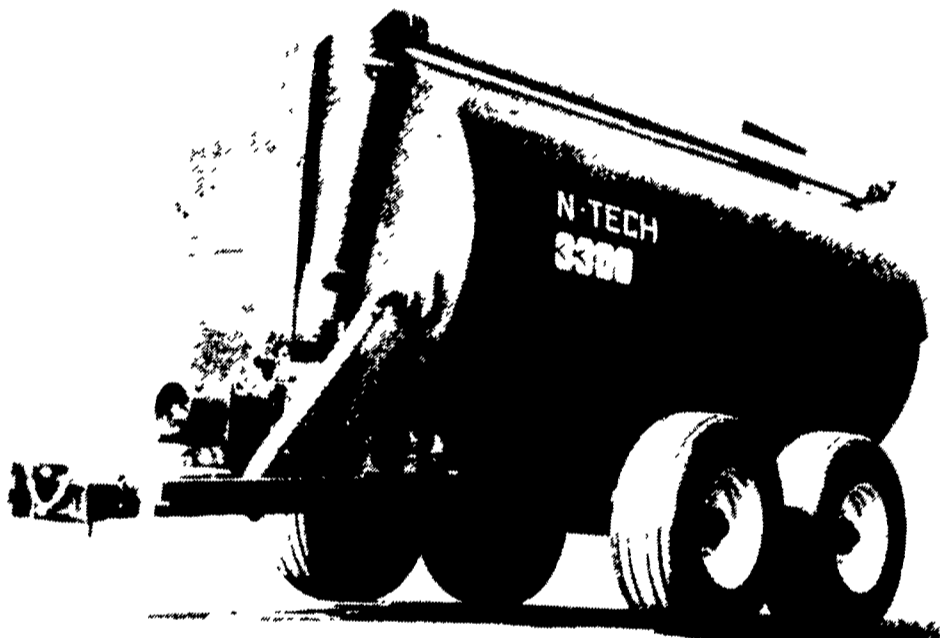

**Round Tank**

Stronger than oval. Prevents excessive shift of center of gravity found in oval tanks.

**Large Filler Hatch - 30 by 30 inch**

**Brakes with Cab Control**

Provides braking forward and reverse, uphill and downhill. Visual brake monitor tells when brakes are off.

**Top Spread Nozzle**

30 to 40 foot spread pattern. Large droplet pattern minimizes "fog" and drift characteristic of slinger spreaders. Eliminates unseen accidental discharge inherent with bottom valve slinger type tanks.

**Forward Slope Design**

Maintains drawbar weight as tank is emptied.

**Front Mount Pump**

Allows over top discharge.

**Adjustable Axle Setting**

Allows adjustable weight on drawbar.

Now Available With 4" Spindles And  
Semi-Trailer Brakes!

**Experience can't  
be imitated...  
quality can't be  
copied...Hanson  
can't be beat!**

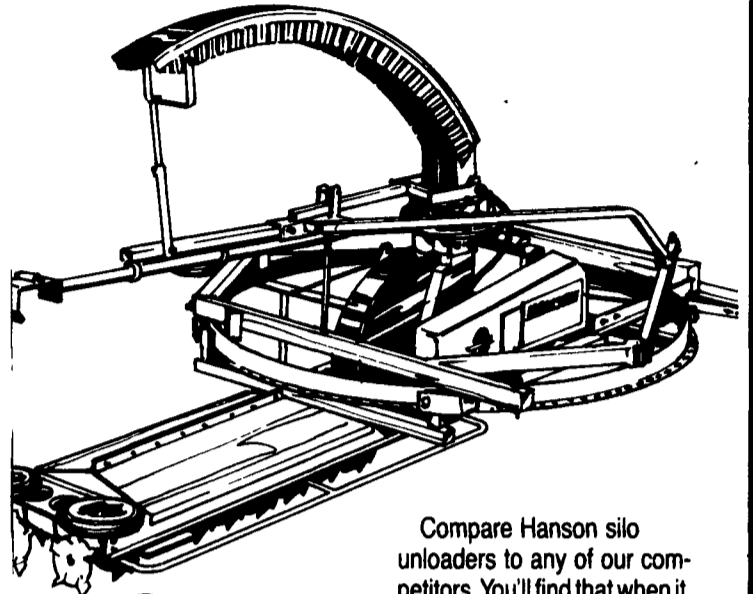

Compare Hanson silo unloaders to any of our competitors. You'll find that when it comes to value, there's no competition. Hanson. There really *is* a difference.



**METKO**

CONVEYING — FEEDING  
EQUIPMENT SPECIALISTS

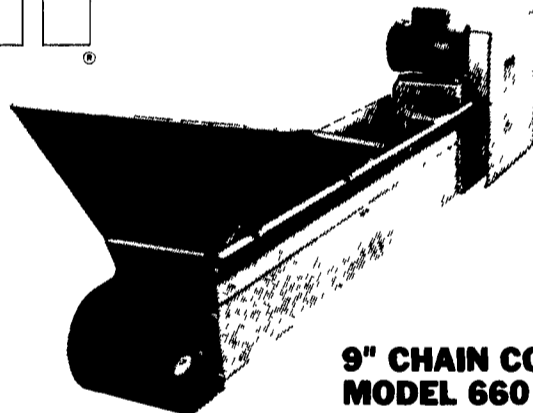

**9" CHAIN CONVEYOR  
MODEL 660**

**COMPARE THESE FEATURES:**

- RIGID-LOCK SECTIONS
- MODULAR SECTIONS
- ONE PIECE TROUGH
- ALL ADJUSTMENTS IN HEAD
- FULLY GREASEABLE-HEAD/BASE
- DOUBLE HUB C.I. SPROCKET
- GALVANIZED SECTIONS
- #62 CONNECTING LINK
- SNAP-ON COVERS
- PATENT PENDING

**METKO'S EXCLUSIVE FEATURE: Rigid Lock® SECTION . . .**

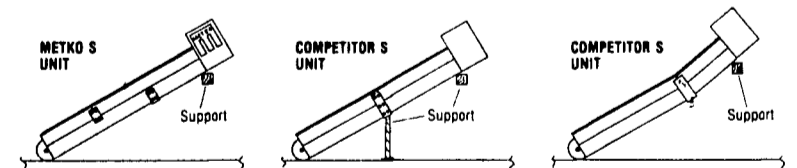

**. . . CLEAR SPAN UP TO 30 FEET WITH ONLY END SUPPORTS.**

This exclusive feature has the versatility of modular sections yet maintains the strength of a completely welded unit.

**4 COMPANIES PROVIDING YOU THE BEST PRODUCTS AVAILABLE!**

**THE  
4ORCE**

HANSON • J&D MANUFACTURING • METKO • N-TECH

DEALERS THROUGHOUT PA, VA, MD, W.V.  
LOCAL WAREHOUSE # 301-223-5151

8 AM to 5 PM M-F

CALL FOR THE DEALER NEAREST YOU

or

CONTACT: KRIS KNUDSEN AREA MANAGER

717-653-0385 FAX 717-653-0243