

# FOCUS

(Continued from Page A33)

Crop/Feedstuff	Relative Feed Value	@ DM %
<b>Table 1. Grains</b>		
1 EAR CORN.....	92.88 Per Ton	85
2 EAR CORN, high moisture.....	67.93 Per Ton	65
3 EAR CORN, bushel basket.....	1.63 Per Bu.	85
4 CORN, shelled, high-moisture ...	83.38 Per Ton	72
5 OATS, spring.....	1.70 Per Bu.	90
6 BARLEY, winter.....	2.78 Per Bu.	89
7 WHEAT, winter.....	3.24 Per Bu.	86
8 RYE, winter.....	3.13 Per Bu.	88
9 SORGHUM, grain.....	2.82 Per Bu.	89
10 SOYBEANS, whole, raw.....	6.56 Per Bu.	90

Crop/Feedstuff	Relative Feed Value	@ DM %
<b>Table 2. Supplements &amp; Extenders</b>		
11 COTTONSEED MEAL.....	10.94 Per Cwt.	93
12 BREWER'S GRAIN, wet.....	39.26 Per Ton	24
13 BREWER'S GRAIN, dried.....	149.61 Per Ton	92
14 DIST. CORN GRAIN, dried.....	167.17 Per Ton	93
15 HOMINY FEED.....	5.89 Per Cwt.	91
16 CORN GLUTEN FEED.....	7.65 Per Cwt.	90
17 WHEAT BRAN.....	5.72 Per Cwt.	89
18 WHEAT MIDS.....	6.38 Per Cwt.	90
19 BEET PULP, dried.....	4.85 Per Cwt.	91

Crop/Feedstuff	Relative Feed Value	@ DM %
<b>Table 3. Hay</b>		
20 LEGUME.....	109.20 Per Ton	87
21 MIXED, mainly legume.....	103.36 Per Ton	87
22 MIXED, mainly grass.....	84.95 Per Ton	88
23 GRASS.....	81.00 Per Ton	89

Crop/Feedstuff	Relative Feed Value	@ DM %
<b>Table 4. Silages</b>		
24 CORN.....	32.95 Per Ton	34
25 LEGUME, haycrop.....	58.09 Per Ton	47
26 MIXED, mainly legume.....	53.55 Per Ton	46
27 MIXED, mainly grass.....	42.34 Per Ton	43
28 GRASS, haycrop.....	37.09 Per Ton	40
29 SMALL GRAIN.....	41.48 Per Ton	37
30 SORGHUM-SUDAN.....	34.75 Per Ton	34

Based on nutrient values in Penn State University Feeds Library.

Program by:  
W.K. Waters, Dept. of Ag. Econ. & Rural Soc., Penn State University.

## Average Farm Feed Costs For Handy Reference

To help farmers across the state to have handy reference of commodity input costs in their feeding operations for DHIA record sheets or to develop livestock feed cost data, here's this week's average costs of various ingredients as compiled from regional reports across the state of Pennsylvania. Remember these are averages so you will need to adjust your figures up or down according to your location and the quality of your crop.

Corn, No. 2y - 2.95 BU. 5.28 CWT.  
Wheat, No. 2 - 3.41 BU. 5.69 CWT.  
Barley, No. 3 - 1.81 BU. 3.87 CWT.  
Oats, No. 2 - 1.82 BU. 5.68 CWT.  
Soybeans, No. 1 - 5.81 BU. 9.70 CWT.  
Ear Corn - 84.92 BU. 4.25 CWT.  
Alfalfa Hay - 93.75 TON 4.69 CWT.  
Mixed Hay - 98.75 TON 4.94 CWT.  
Timothy Hay - 94.25 TON 4.71 CWT.



## How Does Your Herd Compare?

STATE COLLEGE (Centre Co.) — This data is pulled from Pennsylvania DHIA's mainframe computer each week. It is a one-week summary representing approximately one-fourth of the herds on test, as they are tested monthly.

These data are valuable from a business management standpoint and can be used for comparing your operations to the averages from almost 1,400 herds across the state.

DHIA Averages for all herds processed between 6/20/92 and 6/27/92

Number of Herds Processed	1,407
Number of Cows Processed	83,967
Number of Cows Per Herd	59.6
Milk Per Cow (Lbs)	18,368
%-Fat	3.72
Fat Per Cow (Lbs)	684
%-Protein	3.18
Protein Per Cow (Lbs)	585
Average Days in Milk Per Cow	318
*Value for CWT Milk(\$)	12.95
*Value for CWT Grain(\$)	7.78
*Value for CWT Hay(\$)	4.50
*Value for CWT Silage(\$)	1.55
*Value for Pasture Per Day(\$)	.29
*Value for Milk Per Cow Per Year(\$)	2,380
*Feed Consumed Per Cow Per Year(Lbs)	
A: Grain	7,347
B: Hay	2,352
C: Silage	14,719
D: Day Pasture	59
*Feed Cost Per Cow Per Year(\$)	572
A: Grain	105
B: Hay	229
C: Silage	17
D: Pasture	
*Total Feed Cost Per Cow Per Year(\$)	925
*Income Over Feed Costs Per Year(\$)	1,455
*Grain to Milk Ratio	1:2.4
*Feed Cost Per CWT Milk(\$)	5.04
Avg Level For 1,195 SCC Herds	319,528

\*Member generated figures

BUY, SELL, TRADE OR RENT THROUGH THE CLASSIFIED ADS  
PHONE: 717-626-1164 or 717-394-3047

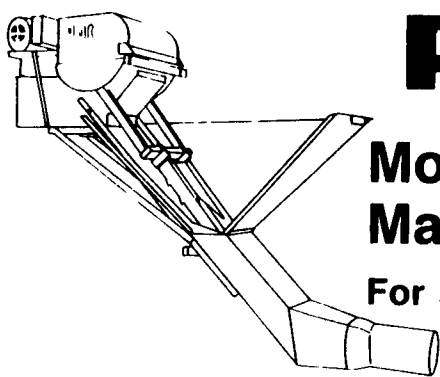

### Patz Model 1512 Manure Pump

For slurry manure

- Handle high volumes of free-flowing manure or slurry with fine-cut bedding.
- Moves manure underground through 15" or 12" PVC pipe to storage area.
- Stroke length offers three adjustments to match manure consistency.
- All moving parts removable for easy service.
- Install easier and faster to minimize investment.
- Big 180 gallon hopper.
- Ends daily hauling. Time savings and fertilizer savings pay for investments.
- Patz financing with monthly or annual payments makes it affordable.

See Us At The Penn State Animal Housing Expo July 14-15, 1992  
Loc. Lebanon Fair Grounds



**Cedar Crest Equipment**  
Two Convenient Locations  
608 Evergreen Rd. Lebanon, PA 17042 (717) 270-6600  
RD 2 Box 271 East Earl, PA 17519 (717) 354-0584

WE CUSTOM DESIGN SYSTEMS FOR YOU

## DO A GOOD TURN

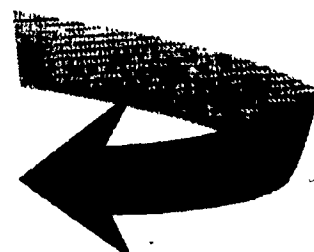

Turn in your old sweep arm auger unloader and put ForceFlo™ unloader's dual action to work for you.

The ForceFlo power sweep auger unloader is a powerful way to handle a Harvestore® brand structure full of high moisture grain. Whenever the discharge auger is operated, the sweep auger also automatically goes to work. This forceful sweeping action is continuously undermining and removing grain from the bottom of the structure. Grain has less of a chance to set up and compact.



Turn in your old sweep arm unloader for ForceFlo's improved performance. Special trade-in deals and low interest financing packages are now in effect. Contact your authorized A.O. Smith Harvestore Products, Inc. dealer today for more information.

Now is a good time to trade in your old sweep arm auger unloader and add a new twist to your feeding schedule.



ENDLESS MOUNTAINS  
HARVESTORE® SYSTEMS, INC.

"Your local, independent, authorized Harvestore Systems Dealer"

BRANCH OFFICE:  
Rt. 15 South (Dow Building)  
P.O. Box 612  
Lewisburg, PA 17837  
(717) 523-6600

MAIN OFFICE:  
Route 6, PO Box G  
(Across From Sinbad's  
Restaurant)  
Wysox, PA 18854  
(717) 265-2200

#### NOTICE

The information contained herein is general in nature and is drawn from sources deemed to be reliable. It is intended for general information purposes only. A particular farming operation may experience all, some, or none of these results.

© 1992 All rights reserved. ForceFlo is a trademark, Harvestore is a registered trademark of A.O. Smith Harvestore Products, Inc. 345 Harvestore Drive DeKalb, IL 60115 815-756-1551