

QUALITY FARM EQUIPMENT

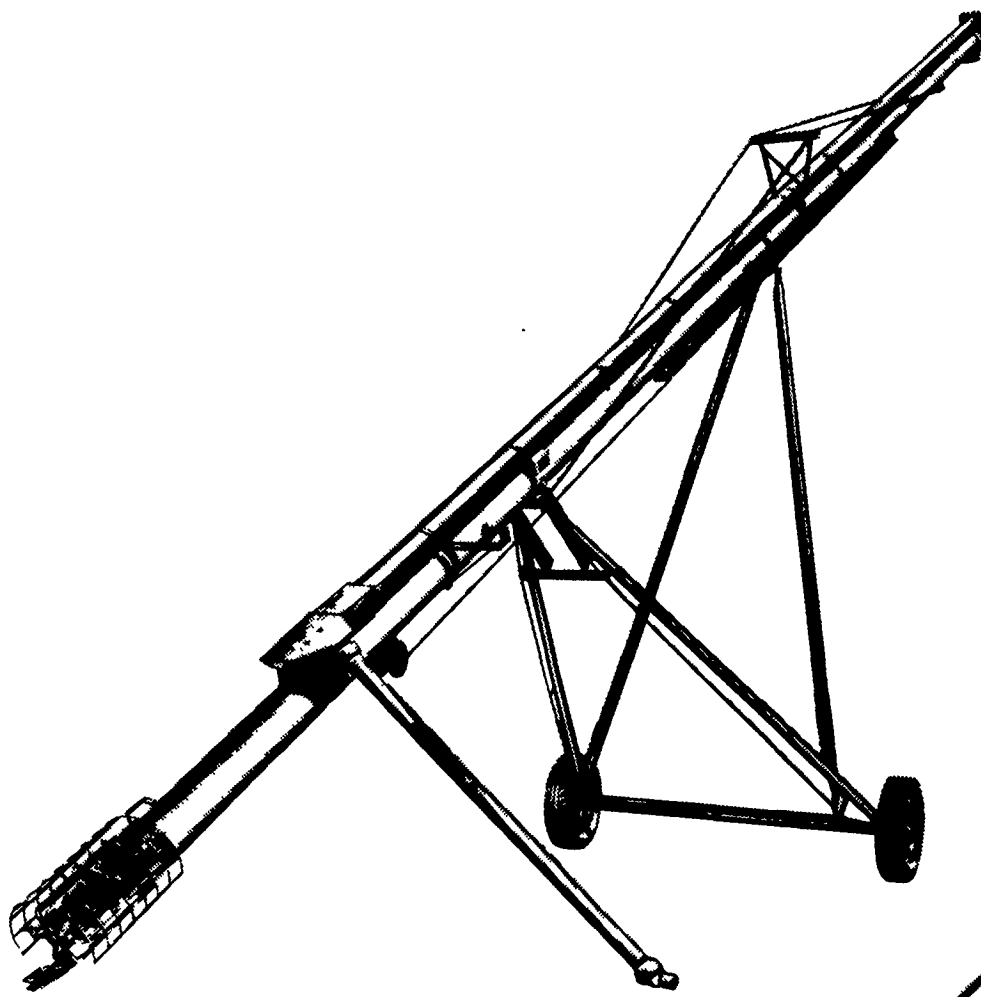

When you buy
WESTFIELD®
You buy the best

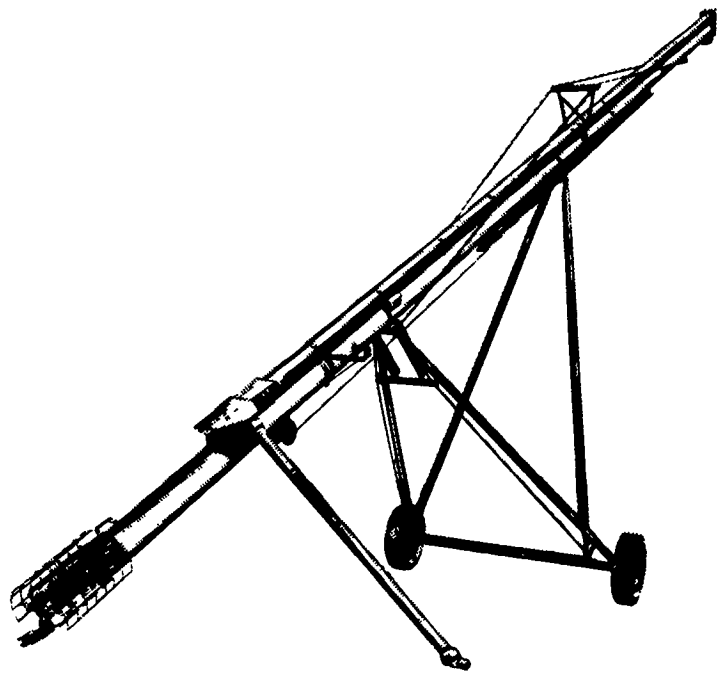
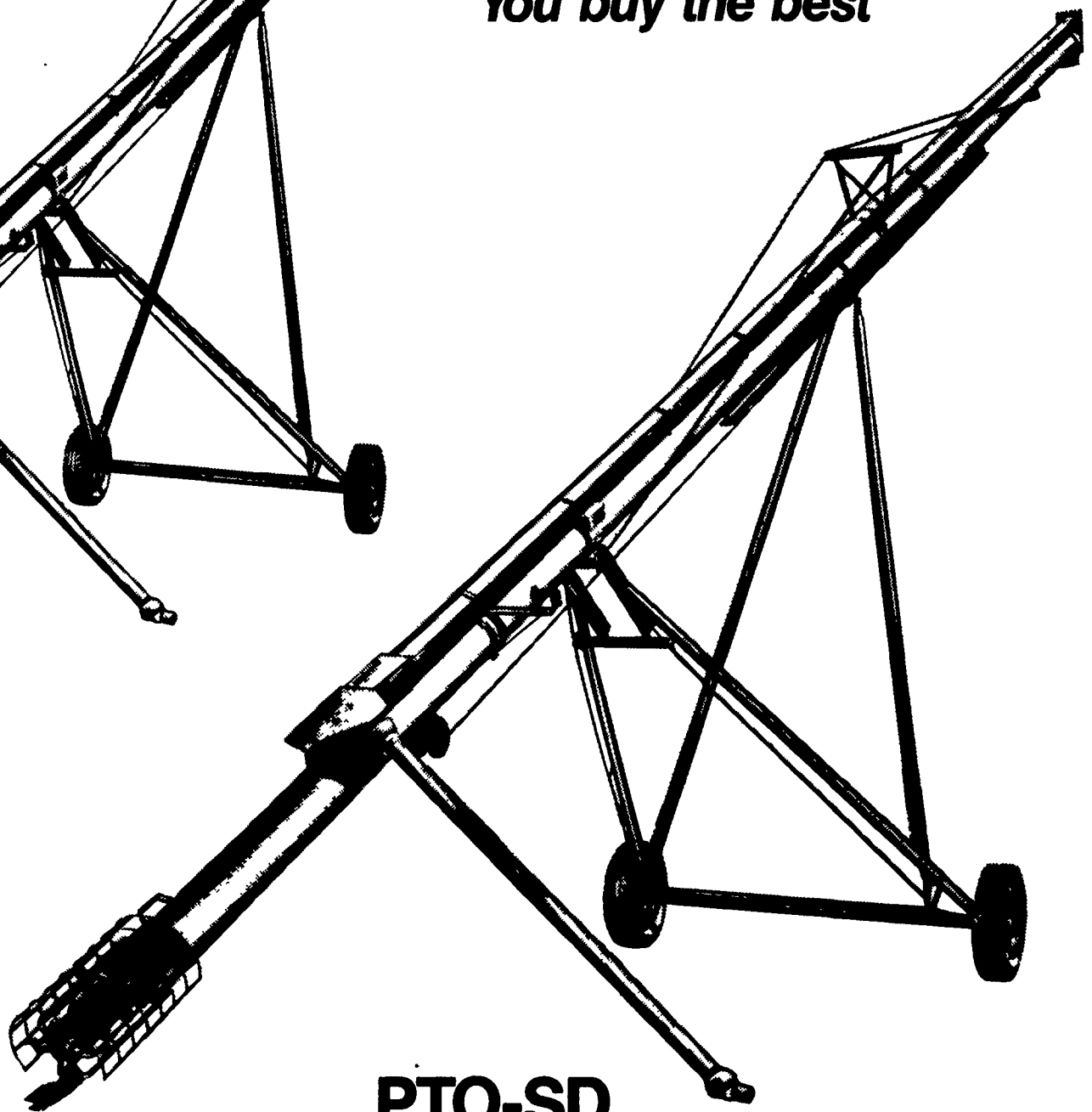

PTO-SD 6, 7, 8 or 10" diameters Models up to 71 feet

North America's leading auger manufacturer brings you quality and dependability at a very competitive price for the best auger value your money can buy.

Each Westfield model has been engineered to give top performance with features like extra heavy gauge double intake flighting, and high speed bearings for years of trouble free service.

Westfield's PTO Shaft Drive model features a gear box connected directly to the auger driveshaft with a flex coupler and shear bolt for the most positive auger drive available.

The gear box can be flipped for right or left hand operation. A non-separable 60 - 80" PTO shaft and handy PTO transport saddle are standard.

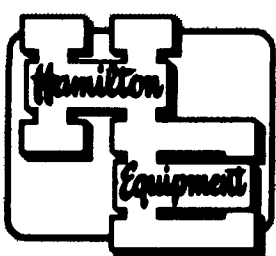

Telephone (717) 733-7951

HAMILTON EQUIPMENT, INC.

Wholesale Distributors

Visit Our Exhibit During Ag Progress Days-Located On E. 1st St.

Ephrata, PA



Raphine, VA