

n The Fast Lane

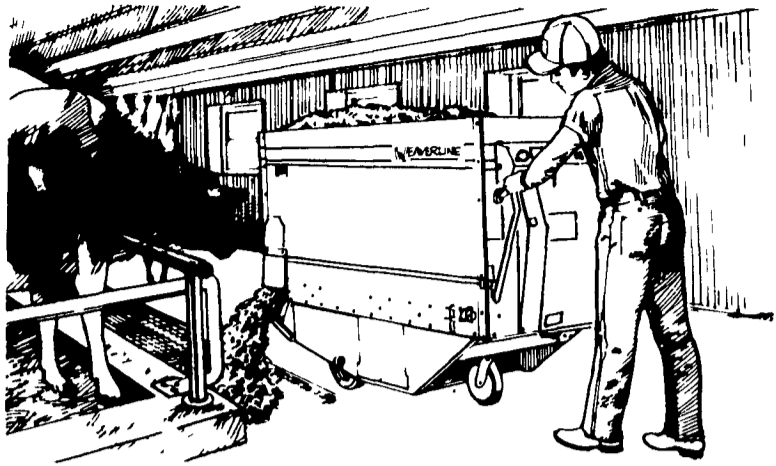

NE

rline Carts. . .

Good Feeding

Amazing Control From 1st
Row To The Last
You Can Vary The Amount
To Each Cow
Discharge Door Prevents
Spill While In Transport
You Can Observe & Adjust
To Each Cow's Appetite &
Feed

3. A Reliable Cart

- 24 Years of Satisfied Weaverline Cart Users
- Designed, Tested & Built for Long Life
- Handy, Dependable, Long Life Battery Power
- Choice Of Stainless Steel Or Painted Metal

AT THE RYDER SUPPLY DISPLAY-BOOTH 342

PRO
FREE!

FEATURES

- Patented pulley/cable drink closure:
 - drink closures require little effort to actuate. **EASY FOR SMALL LIVESTOCK TO DRINK.**
 - allows water level to be set for different operations
 - keeps freezing air out if water level drops unexpectedly
- Closure keeps water cool and palatable in extreme hot weather for better livestock gains and milk production. Prevents algae from forming, keeps water cleaner.
- Valve
 - anti-siphoning
 - instant-on — 18 GPM
- Insulation value: R-27
- Rounded edges for livestock protection
- Recessed drain holes for easy cleaning
- Easy installation
- Uses no electricity
- Eliminates heating elements and utility bills

Ritchie

A minimum of 10 head keeps water to your animals in sub-zero temperatures

Ask About
Our New
Single-Hole
Energy-Free
Unit!

SPREAD'S THE WORD

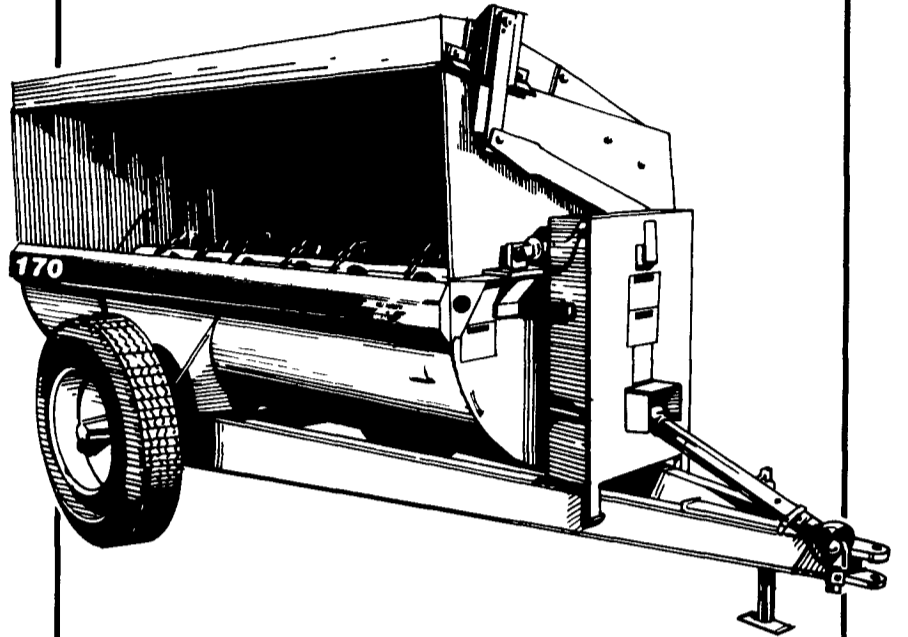

Spread's the word at Ideal Industries with a line of manure spreaders that are big on performance - but easy on your budget! Ideal's Nu Hawk flail tank spreaders offer a more efficient, less expensive solution to all your manure spreader needs. And Nu Hawk spreaders are competitively priced to provide a more economical way to fertilize and build up the organic matter in your soil.

Built to meet your complete loading and spreading requirements, Nu Hawk spreaders provide a variety of features and options for consistent year round spreading of all types of manure.

All Nu Hawk models offer either right or left side discharge and a straight or folding rear panel to clear low barn cleaners. As well, Nu Hawk's tractor controlled hydraulic lid openers and copper bearing steel lids and tanks resist damaging corrosive manure acids.

For more information on Ideal's new line of Nu Hawk flail tank spreaders, see your local Nu Hawk dealer.

NU HAWK®

by **IDEAL**

RYDER SUPPLY
CO.

P. O. Box 219
Chambersburg, PA 17201-0219
Phone 717-263-9111