

Starline Belt Feeder, 14 inches wide, new, never set up, 192 feet long. Make an offer Berks Co Call 215/926-3717 8AM to 5PM

- Dealing in used Harvestores
- Rebuilt Goliath & Hercules unloaders
- Goliath II 25', like new, emptied 1 silo
- Quality replacement parts
- Rexnord chains and matching sprockets

In Business 15 Years

CALL (216) 852-4088

**BETTER BILT STORAGE, INC.**

Route 2, Box 262 Sugar Creek, Ohio 44681

### MARTIN'S SILO REPAIR

Moving Concrete Stave Silos

- Gunite Relining
- Fill Pipes
- Distributors
- Roofs
- Replacement Doors
- General Repair

907 Centerville Rd.  
New Holland, PA 17557  
(215) 445-9834

### ZOOK'S SILO REPAIR

Buy And Sell Silos  
General Repair Work  
• Silo Moving

RD 2, Box 90  
Honey Brook, PA 19344 (215) 273-9211

### 3 SILOS AND UNLOADERS

WANTED. Used silo 16-18x70 preferably good condition; Used wide front for 3010. 717-665-7399.

We pay top dollar for used Harvestores and Slurry stores 717-354-4051

Lancaster Farming, Saturday, October 20, 1990-C53

Supreme Grain Unloader, fits 20' Harvestore Silo, 5 yrs old, good condition \$2,500. Call 717/599-5917

Van Dale magnematic 360 silo unloader for 22' dia silo, used 1 year, \$3,000 Lackawanna Co 717-587-1725

Lease Direct 8' Baggers For Custom Work

# Agripac

Alberta Ag Industries

8' VERSA BAGGERS AVAILABLE NOW

Corn Silage, Hi-Moisture Corn And Haylage Bags To Fit All Baggers at Fall Discount Prices - 8', 9' & 10' Bags Available

#### NEW AND USED MACHINES AVAILABLE

- LOW CAPITAL INVESTMENT
- EXCELLENT FEED
- CONVENIENT STORAGE
- DURABLE AND DEPENDABLE
- ECONOMICAL
- VERSATILE AND ADAPTABLE



Coming Soon For 1991

## "THE BABY BAGGER"

- Least capital cost unit in the market
- Cost per ton of feed stored for plastic will be less than existing systems
- First viewing at Ohio Science Review
- Truly an exciting Bagger

### AGRIPAC NEW ROUND BALE WRAPPER

An Economical Efficient Method Of Making Silage

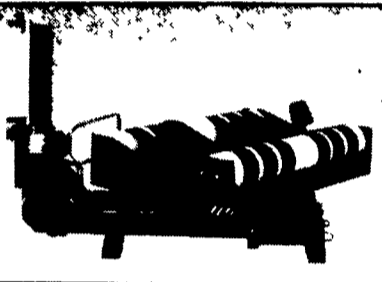

Trailer Type & 3 Pt. Machines Available

- \* Hydraulically Operated
- \* Heavy Duty Hydraulic Drive
- \* Double Acting Hydraulic Ram On Wrapping Bed
- \* Adjustable Pre-Stretcher from 45% to 70%
- \* Lift Arm
- \* 3rd Roller Available

#### This is the Agripac System:

- The lift-arm places the bale on the turn table.
- Film is then attached to one of the bale strings.
- As the turn table is rotating, the rollers will slowly turn the bale.
- The film is cut, film end secured and bale tipped off.

Dealerships Available East of Mississippi River

Mail To: Frank Walters  
P.O. Box 430, 335 E. Main St.  
Brownstown, PA 17508

Name \_\_\_\_\_  
Address \_\_\_\_\_  
City \_\_\_\_\_ State \_\_\_\_\_ Phone \_\_\_\_\_  
 Baggers  Silage Bags  Wrappers  Wrapping Film

Call Toll Free 1-800-661-4150  
Or Frank Walters - 717-656-9919  
Or Write: 335 E. Main St., P.O. Box 430,  
Brownstown, PA 17508 (Lanc. Co.)  
Fax 717/656-9909

# New XC-20 Helps Carry The Load

This high-capacity, Starline® 14-inch belt conveyor is built to stand tough winters and save energy. Spans 20-foot lengths between supports!

- Greater capacity than flat 12-inch and 16-inch belt conveyors
- Heavy-gauge, weather-resistant, galvanized steel construction
- Weather-tight sides and covers
- Deep trough 14-inch airborne belt
- Dependable low horsepower drive
- For use in installations up to 180 feet
- Big capacity, fast, quiet, uniform delivery
- Quiet operation

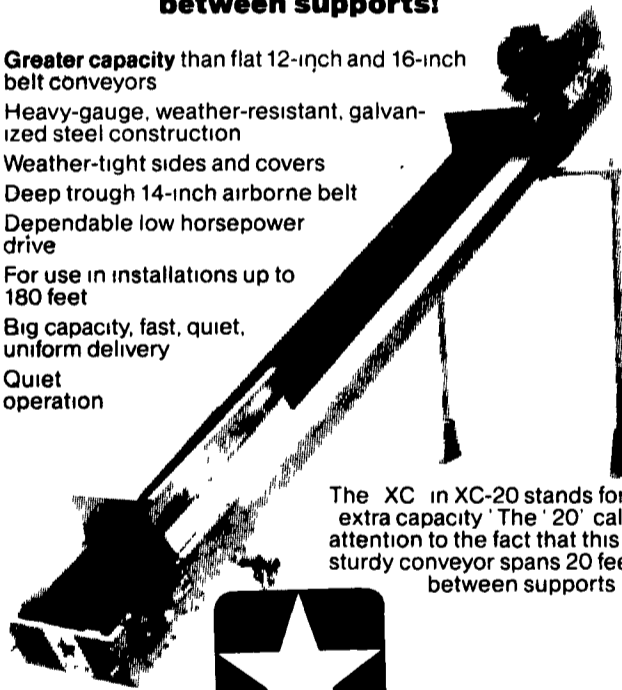

The XC in XC-20 stands for extra capacity. The '20' calls attention to the fact that this sturdy conveyor spans 20 feet between supports



Innovation and leadership from a fine old name.

### USED SUPREME 10 FT. MIXER w/ELECTRONIC SCALES

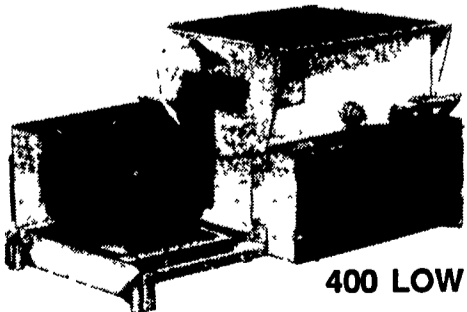

400 LOW PROFILE ROLLER MILLS

Full Line Parts Department For Starline

**DONALD R. NISSLEY**  
RD #1, Willow Street, PA  
(Corner of Rt. 272 S. & Byerland Church Rd.)  
(717) 786-7654



### FIBERGLASS FUNNEL

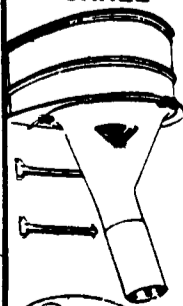

Call For Special Price

### MAY-CO PLASTIC SILO LINERS

To have mold free haylage, corn silage, and high moisture grain, install a May-Co plastic liner, in silos with or without unloaders. Easy to install. Immediate delivery when necessary.

**May-Co Supply Co., Inc.**  
430 Biscayne Rd., Lancaster, PA 17601  
717-569-1011

### S & S SILO REPAIR WE DO

- \* Most Any Kind of Stave Silo Work
  - \* Tear Down & Rebuild Stave Silos
  - \* Shotcrete Relining
  - \* New & Used Extensions
  - \* New & Used Roofs & Chutes
  - \* Unloaders (when available)
  - \* Install Silage Distributors & Fill Pipes
  - \* Repair Level Flo Silage Distributors
  - \* Silo Doors - Most Any Kind
  - \* New Ribstone Staves
- We Buy Some Stave Silos

**SHOTCRETE RELINING**  
Repair Holes & Rough Silo Interiors. Make Your Old Silo Look Like New On The Inside.

RD 2, Box 91A Honey Brook., PA 19344  
215-273-3993

### 4 BUILDINGS AND SUPPLIES

906 BF of beautiful dark black Walnut of which 280 BF is top quality furniture lumber \$ 85/BF 717-536-3614 call after 7PM weekdays

Antique building materials, beams, wide pine boards, flooring, doors, etc 717/249-2304

Dairy barn for sale Also some building materials and lumber 405 Peters Rd, New Holland, PA 717/355-0066

FOR SALE CUSTOM KITCHEN CABINETS U-Shape, Birch, in Cherry stain, in fair to good condition Raised Panel Doors Includes all appliances Make Offer Call 717-866-7250 Lebanon Co

For Sale 2x8 YP, TNG barn flooring, kiln dried, will deliver to Lancaster area Enos King, Box 128, Rebersburg, PA 16872 answering service (814)231-6303

Handling and Decorative sheet rock, 7 and 8 ft lengths, \$7/sheet 717-627-3373 or 717-738-4185

### CUSTOM BUILT POLE BUILDINGS

- Barns
- Stables
- Riding Arenas
- Hangars
- Storage Sheds
- Garages

Call: William Kramer  
**Kramer Pole Building Co.**

872 Ridge Ave., Ephrata, PA 17522  
215-267-4867  
For Free Estimates