

**WARNING,  
ALL SILO OWNERS**

Check Your Silo Now For Rotten Staves. If You Have Been Using Your Silo For 10 To 15 Years For Either Corn Silage Or Haylage, It Is Time To SHOTCRETE.

**WARNING!**  
DETERIORATING  
CONCRETE FROM  
CORN JUICE!

If you have a 15 year old silo... get it fixed or insure it better! But don't wait until the last minute to have it repaired because we may not be able to fix it if you wait too long. REMEMBER your silo will not fall over when it's empty - it will fall over when it's full. It cannot stand on deteriorated concrete...

**Lancaster Silo Co., Inc.**  
2008 Horseshoe Road, Lancaster, Pa. 17601  
717/299-3721

4 20' Badger Unloaders, ranging from \$50 to \$675. One 26' Badger Unloader, \$2,000. One Clay 20' Unloader, good augers, \$50. One Silomatic 26' Unloader, good augers, \$120. 215-273-3993.

Exceptional large property, excellent location, nearly two miles road frontage, outstanding buildings. Adams County. Only serious inquires please. For detailed information reply

to: Box D-37, c/o Lancaster Farming, P.O.B. 609, Ephrata, PA 17522.

Farm Master FB95 stainless steel tumble mixer w/ motor. 717-529-2629

FOR SALE Patz 98B silo unloader, \$1450.00. (12' to 16' can see operating) (717)865-7240 can deliver.

Jamesway 20' VII unloader complete; Jamesway shuttle stroke barn cleaner unit with paddles. Cumberland Co. 717-776-6833.

**MAY-CO  
PLASTIC SILO LINERS**

To have mold free haylage, corn silage, and high moisture grain, install a May-Co plastic liner, in silos with or without unloaders. Easy to install. Immediate delivery when necessary.

**May-Co Supply Co., Inc.**  
430 Biscayne Rd., Lancaster, PA 17601  
717-569-1011

**SEE LANCASTER SILO  
FOR SAVINGS ON  
QUALITY EQUIPMENT**

- Van Dale Unloaders
- Van Dale Orbit Mixers
- Hanson Silo Unloaders
- Knight Spreaders
- Knight Reel Auggie
- Lancaster Feeders

**SPECIAL - New Model 2250  
Knight Mixer - 173 Bu.  
\$13,800 (Demo)**

**THIS IS THE BEST  
CORN SILAGE  
SILO UNLOADER THAT  
MONEY CAN BUY!**



**HANSON TRUE RING DRIVE UNLOADERS  
DUE NEXT WEEK**  
Nobody but nobody beats our price on ring drive unloaders!

**USED EQUIPMENT**

- Used 56" Blower, \$1200. Good
- Used Chuck Wagon, 3 Beater \$1,200
- Agitator Filler/Basin Pump Demo \$5,900
- 14' Patz Unloader, late model, very good shape
- Farmmaster 216 Portable Mixer - Special \$8,000
- Farm Gates 4', 8', 10', 12', 14', 16' In Stock
- 40 Ft. Jamesway Shuttle Feeder
- 125 HP VM Diesel Engine - \$1,000
- 18 HP 2 Cyl. Lister Starter & Alt. Rebuilt - \$1,200
- Knight 716 "Slinger" Spreader - New - \$9,300
- Used 10'x60' Silo
- Used 12'x60' Silo

**Lancaster Silo Co., Inc.**

2008 Horseshoe Rd. • Lancaster, PA • (717) 299-3721

**OSWALT** Model 180 and 230  
**TMR/HAY  
PROCESSORS**

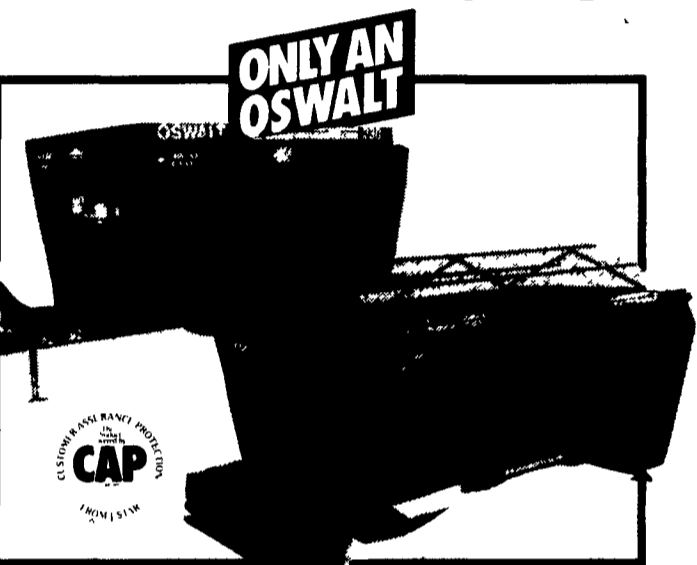

These Oswalt Mixers do a better job of mixing and carry the industry's only five-year mixer warranty!

YOU WON'T BEAT OUR PRICES & SERVICE

**LAPP'S**

**BARN EQUIPMENT**

5935 OLD PHILADELPHIA PIKE, GAP, PA 17527  
PHONE: 717-442-8134  
— Radio Dispatched Trucks —

**Starline's® ALL NEW  
SURFACE DRIVE UNLOADER**

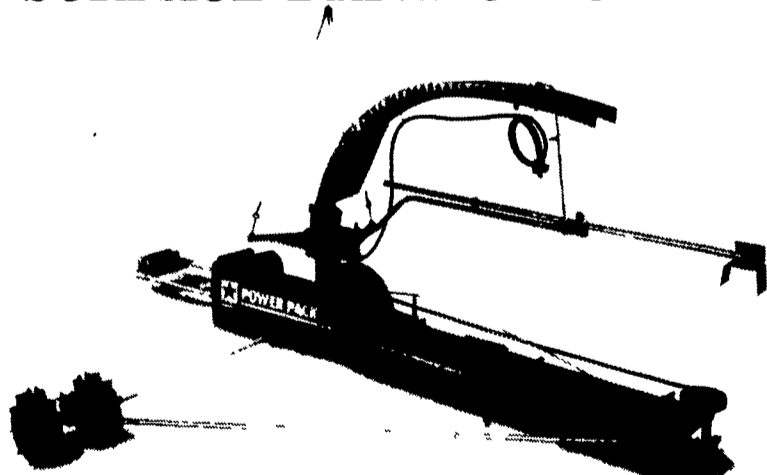

FIBERGLASS FUNNEL

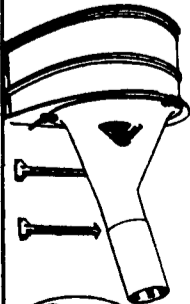

Feature By Feature. You'll Find This Unloader Beats Them All!

**SPECIAL**

**New Model 230 Mixer,  
177 Bu. Capacity  
\$15,000 Demo**

**INVENTORY REDUCTION SALE  
SAT., APRIL 7th  
Details To Follow**

Full Line Parts Department For Starline



**DONALD R. NISSLEY**

RD #1, Willow Street, PA  
(Corner of Rt. 272 S. & Byerland Church Rd.)

(717) 786-7654



**CONVEYING AND FEEDING  
EQUIPMENT SPECIALISTS**

METKO has a variety of chain or belt conveyors and feeders to satisfy your feeding requirements.

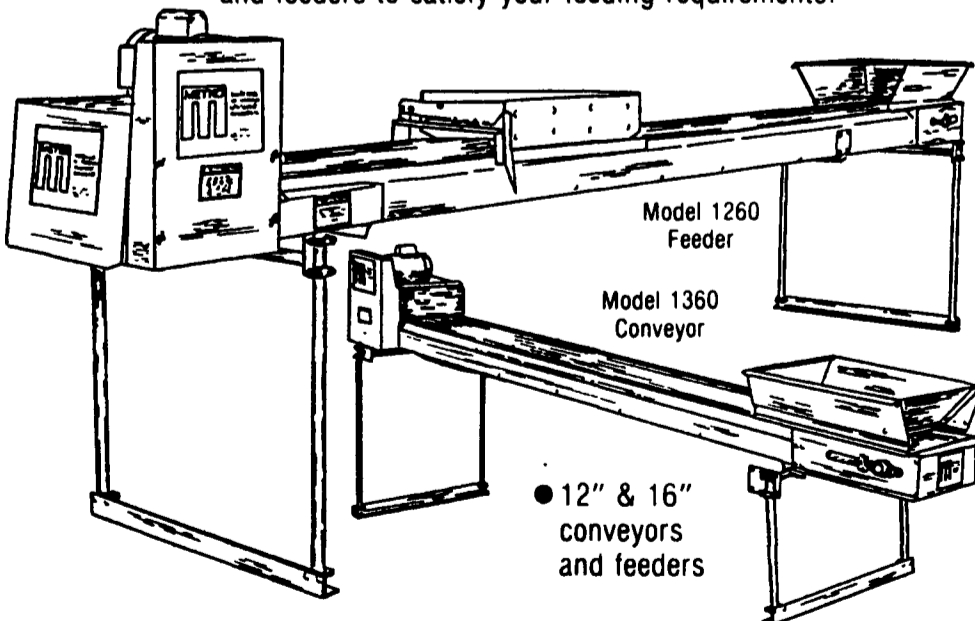

• 12" & 16" conveyors and feeders

- Simplicity of design and operation on all Metko products
- Especially designed for delivery of feeds from up to 3 silo unloaders
- Low maintenance • Greaseable bearings • Low horsepower requirements.

**IF YOU LIKE QUALITY, YOU'LL LIKE METKO**

For more information about the Metko line or a dealer nearest you, call or write METKO, INC., 1251 Milwaukee Drive, New Holstein, WI 53061, 414-898-4221

— OR —

**ART SHANE - AREA REPRESENTATIVE - (703) 837-1114**