

1 FARM EQUIPMENT

KELLY RYAN
BIG BAGGER



KELLY RYAN
New Designed
Baggers 8' and 9'
Hi-Rise 2 Wheel
and
10' & 12' Overbeam
4 Wheel All Self-
Cleaning Baggers

AG PRODUCTS
CO., INC.
Ph. 717-328-3177

IH 1066 good running tractor
Oliver 1850, diesel, w/good rubber
Long R9500 diesel w/Perkins engine
MF 175 diesel, multi power, 16.9x28 new rubber
MF 178 diesel, good running tractor
MF 135 gas, PS, with loader
MF 510 combine w/cab & air, 13' cut, late model
MF loader w/bucket
MF front end weights for late model tractor
Engine parts for 478 GMC diesel.
6 cyl. Hercules crank shafts

MF Tractor Parts Dismantling: 20, 30, 35, 40, 50, 65, 165, 175, 180, 1130, 1135

Jonas W. Nolt
403 Centerville Rd., Newville, PA 17241
717-776-6242 No Sunday Calls
No Out-Of-State Personal Checks

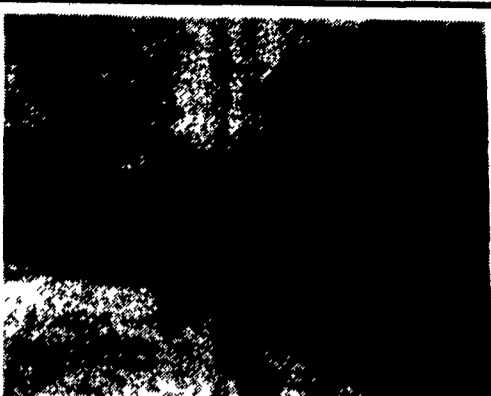

1975 JD 410, Sharp
(717) 859-3283

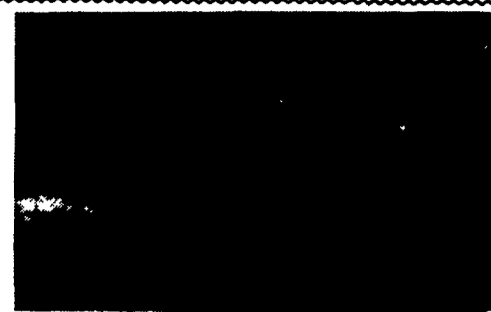

JD 450-B, excellent,
w/6 way blade
\$12,000
(717) 859-3283

YOU CAN'T BUY A BETTER PLANTER FOR LESS MONEY!!
THIS FOLDING 12 ROW WITH MARKERS, MONITOR, CORN & BEAN METERS CAN BE
BOUGHT FOR UNDER \$21,500⁰⁰ (Prior To February 10, 1990)

ECONO-FOLD PLANTER

- The accuracy and consistency of precision placement planting
- The efficiency and speed of 8 and 12 row capacities
- The simple economics of mechanical folding for transport
- KINZE combines em all into the most cost efficient big system planter in the field

A KINZE EXCLUSIVE!

Low profile triple folding markers fold and unfold using the continuous stroke of a single cylinder. A hydraulic alternator valve sequences the marker automatically. You can even lower both markers at one time! The entire system operates independently of the hydraulic lift.

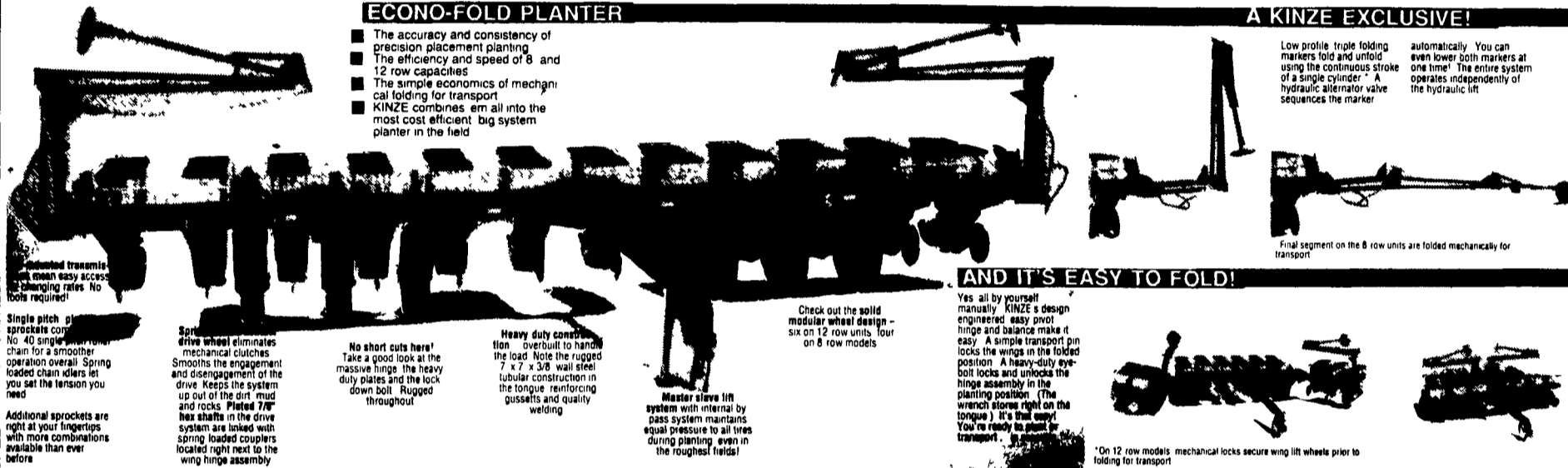

Overhead transmits mean easy access to changing rates. No tools required!

Spring drive wheel eliminates mechanical clutches. Smooths the engagement and disengagement of the drive. Keeps the system up out of the dirt, mud and rocks. Pliated 7/8" hex shafts in the drive system are linked with spring loaded couplers located right next to the wing hinge assembly.

No short cuts here! Take a good look at the massive hinge, the heavy duty plates and the lock down bolt. Rugged throughout.

Heavy duty construction overbuilt to handle the load. Note the rugged 7 x 7 x 3/8 wall steel tubular construction in the tongue reinforcing gussets and quality welding.

Master sleeve lift system with internal by pass system maintains equal pressure to all tires during planting even in the roughest fields!

Check out the solid modular wheel design - six on 12 row units, four on 8 row models.

AND IT'S EASY TO FOLD!

Yes, all by yourself manually. KINZE's design engineered, easy pivot hinge and balance make it easy. A simple transport pin locks the wings in the folded position. A heavy-duty eye-bolt locks and unlocks the hinge assembly in the planting position. (The wrench stores right on the tongue.) It's that easy! You're ready to plant for transport.

*On 12 row models, mechanical locks secure wing lift wheels prior to folding for transport.

NOW IS THE TIME TO DECIDE!!!

WHICH KINZE CONFIGURATION IS RIGHT TO MEET YOUR PLANTING NEEDS?

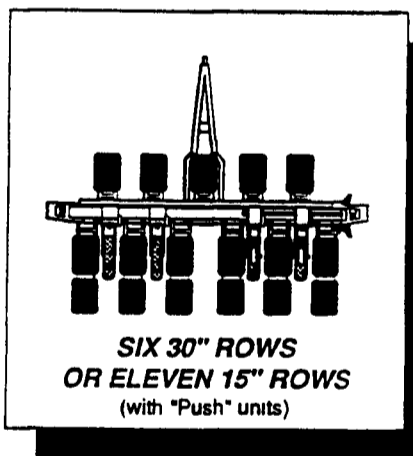
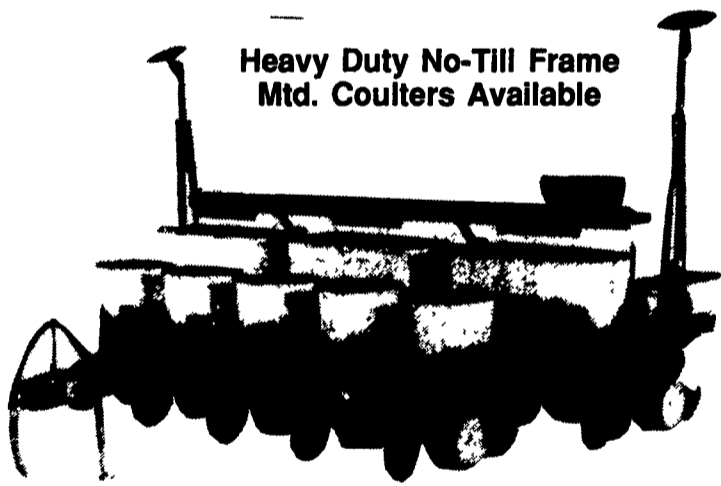
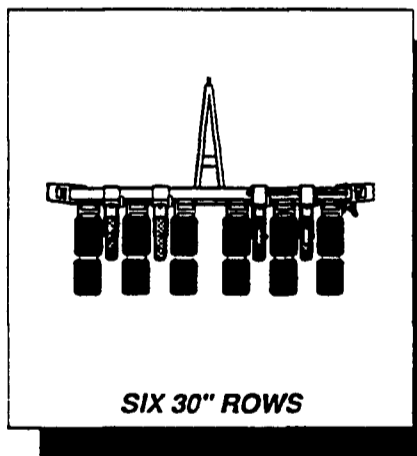

An overhead diagram of planting options, with the same basic planter frame.

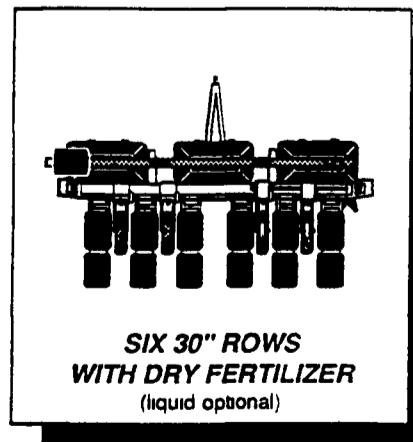
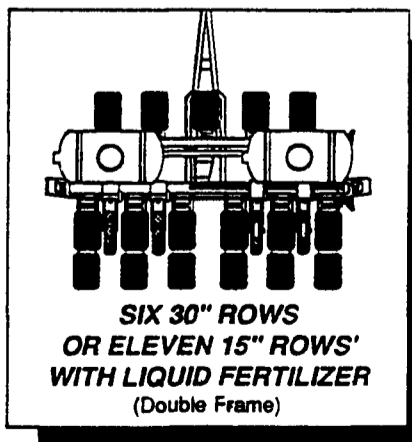
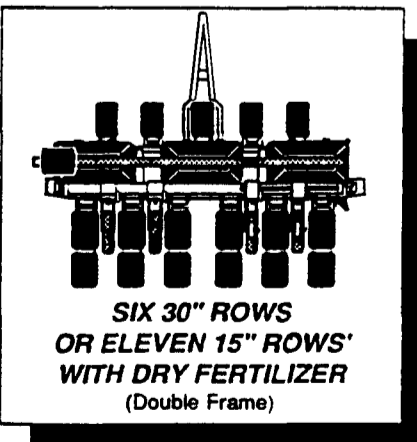

Deliveries Are
Being Made On A
First-Come, First-
Served Basis.
Order Yours Today
For February/
March Delivery!

The
KINZE SERIES II
PLANTER

BINKLEY HURST
BROS INC

133 Rothsville Station Rd
Lititz, PA 17543
Located 1/2 Mile North of Rothsville
(717) 626-4705

MON-FRI 7 AM - 5 PM
SAT 7 AM - 11:30 AM
SUN - CLOSED - THRU'S DAY
EMERGENCY PARTS DEPT (717) 626-0855 (717) 933-4753 (717) 859-8768