

**We at Triple H wish to thank our many loyal customers who have done business with us during the past few years. A special thanks this year to all of the farmers who we have had the privilege of working with in 1989. A partial list of these customers include:**

Blueberry Hill Farm, Hanover, PA  
 Mark Bowman, Hegins, PA  
 Jay Brackbill, Mt. Joy, PA  
 Clarence Burkholder, Myerstown, PA  
 Marlin Campbell, Herndon, PA  
 Delaware State College, Dover, DE  
 Willard Dietrick, Kempton, PA  
 Ern-A-Jean Holstein, Andover, NJ  
 Wil Esbenshade, New Holland, PA  
 Ezra Evans, Medford, NJ  
 Clarence Fittery, Denver, PA  
 A. Fricking & Sons, Mechanicsburg, PA  
 Clarence Garmen, East Earl, PA  
 Ralph Gee, Chambersburg, PA  
 Genfarm Partnership I, Kennedyville, MD  
 Ken Gingrich, Mt Joy, PA  
 Graywood Farms, Peachbottom, PA  
 Hazleton Research, Denver, PA  
 Allen Herr, Christiana, PA  
 Barry High, Westminster, MD  
 Frank & Mary Huber, Mt Joy, PA  
 Elvin Hurst, Lititz, PA  
 Jones Dairy Service, Medford, NJ  
 Robert Lefever, Lancaster, PA  
 Martin Bros., Loysville, PA  
 Mason Bros., Nottingham, PA  
 Jonas Nolt, Lititz, PA  
 Jim Rodichok, Tower City, PA  
 Bryn Ruck, Andrews, PA  
 Paul Stoss, Lehighton, PA  
 Kent Strock, Mechanicsburg, PA  
 John Stump, Bernville, PA  
 George Tallman, Tower City, PA  
 Top Brass Farm, Newton, NJ  
 Charles & Kate Tweedy, Moorestown, NJ  
 University of Delaware, Georgetown, DE  
 Paul Weaver, Myerstown, PA  
 Ken Wenger, Ronks, PA  
 Edwin Wise, Ephrata, PA

**To these and many other farmers, we say thank you and we wish you a very prosperous year in 1990.**

**Happy New Year From  
Your Friends At**



"Experience And Quality"  
From Concept...  
To Design...  
To Completion...

**TRIPLE H Construction**  
430 Springville Rd., Ephrata, PA 17522

**Phone: 717-738-2142**

Custom Builders of Dairy, Hog, Poultry, Horse, Storage,  
Residential And Commercial Buildings.

## DER Bay Clean-up Campaign At Farm Show

HARRISBURG (Dauphin Co.) — Say Yes! That's the theme of a new campaign organized by the Pennsylvania Department of Environmental Resources Chesapeake Bay Education Office encouraging individuals to do their part to improve the quality of water reaching the Chesapeake Bay from the Commonwealth.

In association with the Harrisburg offices of the Alliance for the Chesapeake Bay and the Chesapeake Bay Foundation, the Bay Education Office will display an exhibit outlining simple environmental protection practices at the 1990 Farm Show in Harrisburg.

Because the state contributes more than 50 percent of the freshwater reaching the Chesapeake Bay through the Susquehanna and Potomac Rivers and areas that drain directly into the Bay, Pennsylvanians play an important role in improving the condition of the Chesapeake.

Highlighted by a six-foot light-house, the Chesapeake Bay exhibit will invite Pennsylvanians to pledge to implement simple environmental protection activities that can positively affect the Chesapeake Bay and other environmental concerns.

Many of the actions outlined by the exhibit can be done by an individual in his or her own home or office. Some of the suggestions include properly applying lawn

and garden pesticides, contributing to recycling drives, and improving lawn care techniques.

Other items on the pledge list relate directly to agriculture, a source of many of the pollutants harming the Bay today. Possible pledges for farmers include implementing a nutrient management plan on their farms and providing for permanent vegetative cover along streambanks.

Information on the Pennsylvania Chesapeake Bay Program, a cooperative project between the state Department of Environmental Resources and related State and Federal agencies and organizations to reduce nonpoint source pollution from the Commonwealth, will also be available to Farm Show visitors.

For more information on the Pennsylvania Chesapeake Bay Program, contact the Bay Education Office at 225 Pine Street, Harrisburg, 17101, or call (717) 236-1006.



## Universal<sup>®</sup> Commander Feeder

**NEW!**

- traveling computerized feeder for confinement barns
- helps lower feed costs and improve production
- moves on clogproof track to serve both sides of barn
- dispenses up to 3 feeds with precise measuring and monitoring
- interfaces with your computer at any remote location
- built to take years of punishment

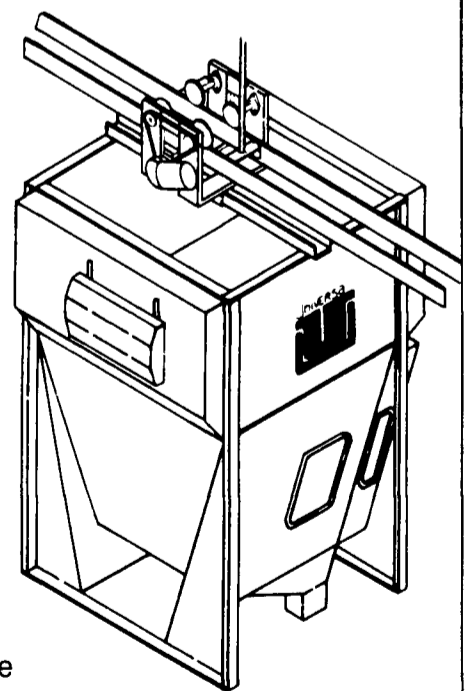

Available only at participating Agway locations.

Vic McMillin  
Conneaut Lake, PA  
814-382-3216

Curt Cassady  
Lititz, PA  
717-626-1065

Arnie Decker  
St. Thomas, PA  
717-369-3607

Ken Whipp  
Thurmont, MD  
301-751-1130

Bill Knisely  
Warriors Mark, PA  
814-692-4110

**AGWAY** Farm Values