

MAILBOX MARKET  
FOR SALE

IH #350 harvester w/1 r. corn head good cond., also a Gehl hi-throw blower excel. cond. Lyc. Co. 717-323-1923.

Reg. 1/4 Arab gelding rides, drives \$1000, P.O.A. pony 13.2 hands, child safe \$400, Reg. Palomino QH colt, \$500. 717-665-3663.

Single seat mennonite carriage very good 6 yr. old, GE 400 AMP D.C. welder, Wis engine on trailer good no longer needed. Allen M Weaver, RR 2, Box 2451, East Earl, Pa. 17519. Union Grove.

400 4x8x16 new concrete solid faced blocks .20 ea. OBO #12 MF baler w/thrower \$500. Lanc. Co. 215-445-6049.

JD 60 STD. nice, \$4000. JD 50, \$1500. JD H, new tire, \$1400. JD 4230, 2000 hrs., \$18,000. Chester Co. 215-458-8433.

Fox Super D forage harvester w/3 heads \$5000. JD FBB 15 disc grain drill \$500. York Co. 717-244-3760.

1983 Chev. classic Caprice 4 dr. sdn., loaded, 1 owner, 52,000 mi., B.O. Lehigh Co. 215-965-2622.

Massey 255 tractor w/loader like new \$8500 Gehl 1500 round baler good cond. \$3500. Will deliver. Crawford Co. 814-967-3223.

Purebred German Shepherd puppies, 9 wks. old, no papers, \$50. Sch. Co 717-682-8376.

10' 1987 Eby cattle body, reg. Suffolk ram, ewes & cross lambs. Dauphin Co. 717-545-5181.

Gravity box wagon 8 ton gear flotation tires, extendable tongue good cond., \$600. Fred. Co. 301-293-2527.

1964 Jeep pickup J300, custom cab, 4WD good cond., \$1400. 215-285-2611.

1975 Int. dump truck, \$3000 or trade for dairy cattle; 845 NH round baler; 3 pt. JD chopper. Clarion Co. 814-354-6188.

Shower yearling laying 85% 90¢ ea Levi S. Stoltzfus, 305 E. Eby Rd., Leola, PA 17540.

5000 tobacco lathe \$5/hundred, Farmall A 60" mower cult., \$1500 OBO. Lanc. Co. 717-426-2296.

1980 GMC 6000 366 gas engine cab & chassis, no bed 22,000 lb. GVW \$4500. Snyder Co. 717-694-3618.

1959 Ford 1 ton truck \$1000, F-20 Farmall C plow baler, all \$1100. Alleg. Co. 301-395-5767.

12 steel I-beams 14' long, 20" high, 7" wide, 1/2" thick, \$800. Noah Yoder, RD 1, Box 55B, Meyersdale, Pa. 15552.

2M, 2ME cornpickers, best offer, parts for '75 Dodge 600, '76 Ford 700, approx. 175 chainlink fence. Northampton Co. 215-262-2518.

NI Uni 767 super chopper \$800, 743 w/n.head \$2500 OBO 20x20 tires & wheels; 22 ply. Wash Co. 301-791-9326

3 bred sows, 1 lg. York boar, 3-200# York boars, last year's hay, heavy \$1.25 a bale, 10 shoats, 150 oat straw, \$1.50 a bale, 2 Appaloosa mares. York Co. 717-244-0624.

Int. forage chopper 2R head #550, good cond. York Co. 717-382-4646.

Meyers 6' snow plow Jeep hookup 6 volt. 3 Meyers power angle 7 1/2' plows. Dodge, Chevy, Ford frames. 301-398-7680.

Parting out 1983 Plymouth Reliant, good body & glass, engine has cracked piston. Whole car \$150 Bedford Co. 814-766-2938.

Corn picker side chute w/ carrying pipe, like new. Ben E Stoltzfus, 202 Soapstone Lane, Peach Bottom, PA 17563.

Lancaster Farming Saturday, September 9, 1988-D25

2 white leather show halters (cattle), matching leads \$10 ea. 400 gal. bulk tank, 2 Grove wagons. Juniata Co. 717-527-4552 eves.

1020 McCormick deering new steel cleats some motor parts missing, motor is loose \$250, firm York Co. 717-927-6070 after 8 p.m.

All breed swine sale Sept. 16, 12:30 p.m. at York Fair Swing ring, boars, gilts, 50 feeder pigs for Pa Farm Show York Co. 717-741-0320

Zimmerman dairy manure auger 25' length 12" diameter 540 PTO reversing gear box used only once Lanc. Co. 717-656-7732.

2 grain bins w/drying floors & unloading augers, also 8"x55' loading auger, \$1500 Midd Co 609-448-1241 eves

Coby dump wagon one Pr corn picker, Oliver 5 corn picker, Oliver 2 row corn picker needs clutch. Berks Co. 215-756-6701

Slant bar feed trough 21' on wheels, \$595. Montg Co 215-754-7012

Reg. Black Angus, one open heifer, two cow-calf pairs, excellent 4-H projects. Northampton Co. 215-588-8131 after 5 p.m. eves.

1977 280X new paint 4 spd. air AM-FM Md. inspected 18,000 rebuilt engine, \$2,800. Cecil Co. 301-287-2929.

XT190 tractor good motor, 110 horse \$3500 717-664-4748 eves. after 8 p.m.

1978 Int. truck 1750 loadstar 26,500 GVW eng DT-466 diesel 5+2 speed 18' Parkhorst dump good cond., \$12,000 Gettysburg, 717-334-5978.

GMC 78, 3/4 T, 4x4, auto, AC, 2-owner, cruise, 62,000 miles Sierra Classic trailering special Elkton, Cecil Co 1-301-398-3974

6' hammerknife mower \$900 Pike Co 717-588-6350.

Field cult in good cond 717-263-9349

Smiley woodburner used 2 yrs. accepts 32" logs firebrick lined, blower, catalytic converter \$425, also oat straw \$1/bale. North'd Co 717-275-3212



## POWER SHUTTLE FEEDER - New And Only From Badger Northland

An Employee Owned Company

### The Simplest, Toughest Feeder You Can Buy!

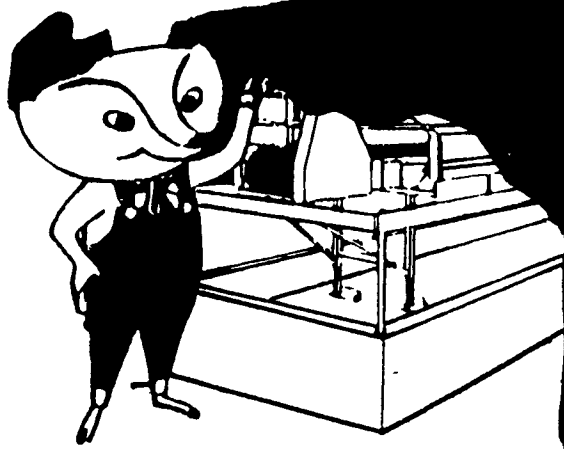

#### BN8900 POWER SHUTTLE FEEDER:

- No conveying belts or chains
- Simple worm gear drive
- 14 gauge galvanized steel trough
- Fast, high-capacity feed distribution
- Ideal center charge replacement feeder

See The New Power Shuttle Feeder  
Ask Your Local Dealer For Details!

#### WAIVER OF FINANCE OR LOW RATE FINANCING AVAILABLE

### The new Badger Frost Busters!

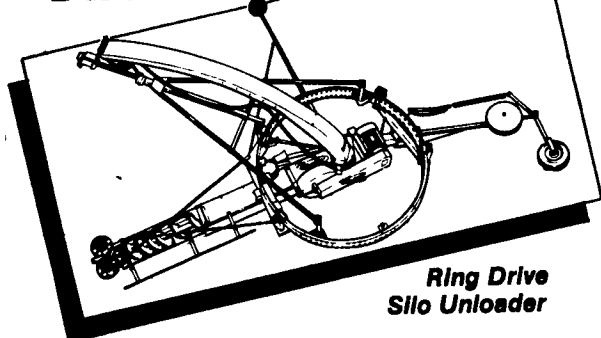

Ring Drive Silo Unloader

- NEW! Center-mounted blower allows for further travel between doors
- NEW! Simple, trouble-free collector ring redesigned for greater ease of service
- NEW! Vertical control guide wheel on auger's outer end adds stability when raising the unloader
- NEW! Three-year limited warranty
- High strength, extra-heavy angle iron frame
- Heavy-duty double wall reinforced drive ring
- Super tough chipper wheel shaves silo wall clean
- Rugged 10" auger with heat treated Zinc Dichromated knives and double flighting on outer end

### Badger Frost Busters!

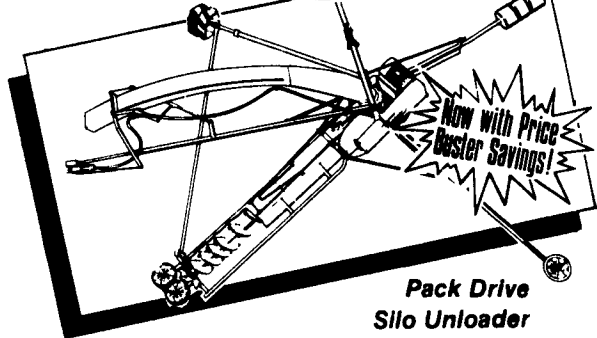

Pack Drive Silo Unloader

- Center-mounted blower allows for further travel between doors
- Simple, trouble-free collector ring redesigned for greater ease of service
- Quick installation and low cost, the ideal replacement unit
- High strength, extra-heavy angle iron frame
- Rugged 10" auger with double flighting on outer end, equipped with heat treated Zinc Dichromated knives
- Heavy-duty chipper wheel shaves silo wall clean

The best Forage Box you can buy is built by



WAIVER OF FINANCE  
TILL 1/1/90 OR LOW  
RATE FINANCING

- 0% For 12 Months OR CASH REBATE
- 7.9% For 24 Months
- 9.9% For 36 Months

#### We Offer A Full Line Of Equipment With Financing Or Leasing

#### CALL YOUR LOCAL BADGER DEALER FOR ALL YOUR EQUIPMENT NEEDS

FANCY FURROW FARMS AG EQUIP., INC.  
RR 1, Uhler Rd.  
Easton, PA 18042  
PH: (215) 252-8828

HESS' EQUIPMENT Sales & Service  
RR 3, Millifinburg, PA 17844  
PH: (717) 966-2720  
966-1998

HONESDALE SPREADING SERVICE INC.  
505 Cliff St.  
Honesdale, PA 18431  
PH: (717) 253-2410

BHM FARM EQUIP. INC.  
RR 1, Annville, PA 17003  
PH: (717) 867-2211

TERRA-VIEW FARMS\*  
RD 4, Jersey Shore, PA 17740  
PH: (717) 398-4177

CECIL DAIRY STORE  
374 Biggs Highway  
Rising Sun, MD 21911  
PH: (301) 658-6923

HEFLIN SALES & SERVICE  
12312 Oak Hill Rd.  
Woodsboro, MD 21798  
PH: (301) 898-3233

CHIDESTER FARMS  
RD 2, Box 75  
Kingsley, PA 18826  
PH: (717) 289-4260

McMILLEN BROS.  
RR 1, Loysville, PA 17047  
PH: (717) 789-3981

MELVIN G. MILLER  
RT 2, Spring Mills, PA 16875  
PH: (814) 422-8279

PIKEVILLE EQUIPMENT INC.  
RT 2, Oley, PA 19547  
PH: (215) 987-8277

FARMER BOY AG  
410 Lincoln Ave.  
Myerstown, PA 17067  
PH: (717) 866-7585

LEONARD WORK  
RR 3, Brookville, PA 15825  
PH: (814) 849-3381

SPE INC.  
RD 1, Box 157  
Towanda, PA 16848  
PH: (717) 265-4440

SHOW EASE STALL CO.  
573 Willow Rd.  
Lancaster, PA 17601  
PH: (717) 299-2536



\* New Dealer

### 1989 BARN PAINTING Latest Developments

- PREPARATION** - High volume water blasting at 1,000 lb. pressure re-surfaces barn siding into a smooth (like new) appearance!
  - Performed by professionals quickly at reasonable cost.
  - By yourself with your own or rented equipment.
  - Or other more conventional methods
- APPLICATION** - To insure better adherence to this super prepared surface, use the best fine bristle brush in four directions to evenly distribute the recommended mil thickness of seal coat coverage.
- SPECIALIZATION** - Every barn is different but generally it's best to use a high quality mildew resistant product, specially formulated to meet the requirements of this partially weathered wood that was and will be weather stressed.
- WARNING** - The modified oil latex is less effective as a wood preserver and actually increases nail & metal deterioration. Deal with home people. At their rates, I could double mine.



Aerial & Latest Equip.  
Estimates Evaluations  
**PHARES S. HURST**  
RD 1 - Box 503  
Narvon, PA 17555  
215-445-6186

### TILLERS AND BCS ATTACHMENTS

#### MODEL 735 FOR THE BIGGER JOBS - A TWO-WHEEL TRACTOR FOR ALL SEASONS

Featuring:

- All Gear Drive, No Belts Or Chains
- Five Speed Transmission
- Differential Allows Zero Turning Radius
- Independent Left & Right Wheel Brakes
- 10 HP Gasoline Engine

3 Year Warranty

Easily Converts To Accept These Attachments

Ask For Demonstration

Just Pull The Pin With Optional "Quick Hitch"



- Sickle Bar Mower
- Log Splitter
- Snow Blower
- Rotary Mower
- Sprayer
- Shredder
- Dozer Blade

12 Years of Professional Sales & Service  
717-738-4215

WES STAUFFER  
ENGINES & EQUIPMENT  
Mon. - Fri. 8 - 7  
Wed. 8 - 5; Sat. 8 - 2  
23 Pleasant Valley Rd.  
East of Ephrata off Rt. 322