



JOHANNING'S

Family Store

"Take Quality Home"

4th ANNIVERSARY SALE

Monday
MARCH 13th
thru
Saturday,
MARCH 18th

DOG FOOD

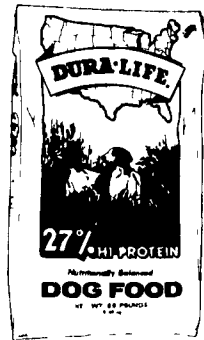

SKU #75010

50 Lb. Bag
\$11.99



SKU #75015

25 Lb.
\$9.99

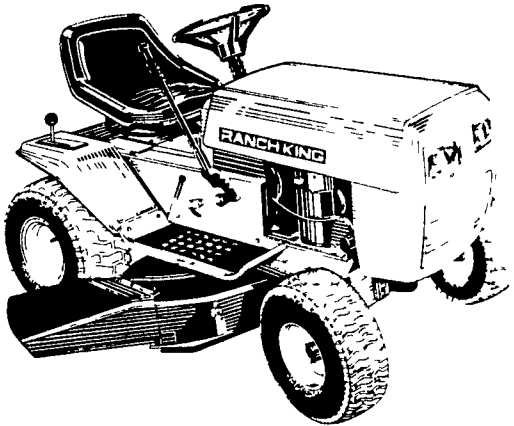

RANCH KING
Model 138-652-205
12 HP / 38" CUT

7-speed Transmatic® Transaxle
Engine: 12 H.P. B&S synchro-balanced.
Drive: 7-speed Transmatic® transaxle drive to wheels.

Forward Speed/MPH: Hi 6.0 Lo 1.3
Fuel Capacity: 1 gallon
Deck: 38" side discharge "High Vacuum" deck with special vacuum lift blade. Quick adjust anti-scalp mowing deck wheels. 5-position cutting height adjustment. Blade engagement lever.
Industrial Engine Has Full 2-Year Warranty

We Service
All Of Our
Lawn And
Garden
Equipment

\$949.00

OPTIONAL REAR
BAGGER \$199.00

FINANCING AVAILABLE As Low As
\$202 Down, \$27 per month

JACOBSEN HOMELITE

TURBO VAC MOWER

- 3½ H.P. • 20" Cut
- Aerodynamic Die Cast Aluminum Deck

Sugg. Retail \$279.99

\$249.95

Rear
Bagger Kit
\$39.99

SELF-PROPELLED
MODEL
Sugg. Retail
\$349.99

\$319.95



REAR TINE TILLERS Model 219-405-205 5 HP/ 18" Cut Reverse Direction Tines

Engine: 5 H.P. B&S, 12.57 cu. in. (206.0 cc). Rewind start.
Drive: Single-speed, 3-step chain reduction drive, 3-step chain reduction wheel.

RPM Forward/Reverse: 1 mph ground speed. 177 rpm tine speed.
Features: 18" width. Zero turning radius-ratchet assembly in wheels. 5-position depth control. Remote throttle. Adjustable side panels. Swing handle.

SKU #15705

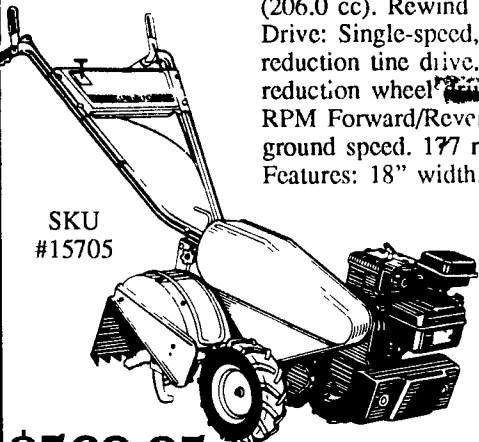

\$569.95

COMMERCIAL HIGH WHEEL MOWER

Model 129-560B-205
5 HP/26" Cut Self-Propelled

Specifications:
Engine: 5 HP B&S 12.57 cu. in. (206.0 cc). Blade Brake Safety System.

Deck: 26" side discharge, 14-gauge steel. Full deck baffles and belt driven blade. Height Adjustment: 5-position single lever: 1" to 4" Wheels: 8.00"x1.75" semi-pneumatic front; 16.00"x1.75" steel spoked pneumatic rear; ball bearings

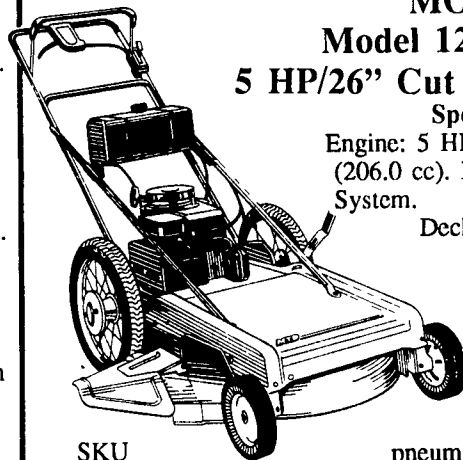

SKU #15691

\$529

PROMO BY CHAPIN®

HI-DENSITY POLY COMPRESSED AIR SPRAYER

- Chemical Resistant Tank
- Wide Easy-Fill Top
- Nozzle Adjusts From Mist To Stream

2 Gallon
\$18.50

3 Gallon
\$19.95

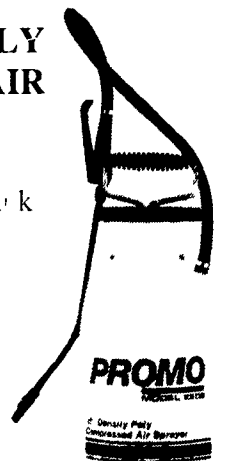

TURFMASTER FERTILIZERS

by Lebanon Chemical Co.

For A Greener, Thicker, Weed Free Lawn



WEED & FEED
5,000 Sq. Ft.

Reg. \$7.49
\$6.49

CRABGRASS CONTROL
5,000 Sq. Ft.

Reg. \$8.99
\$7.99

LAWN FOOD
5,000 Sq. Ft.

Reg. \$6.49
\$5.49

EARTHWAY® PRECISION GARDEN SEEDER

- Saves Time
- Saves Money
- Dependable

Complete With Full Set Of 6 Seed Plates

\$46.99

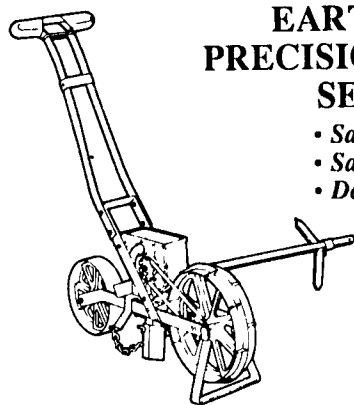

LAWN & GARDEN SPRAYER SKU 52890

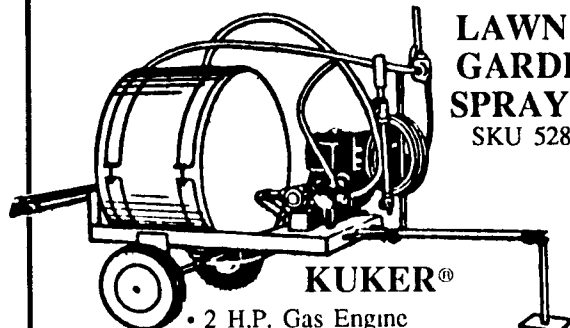

- 2 H.P. Gas Engine
- 25 Gallon Poly Tank
- Handgun w/25' of Hose
- Boom w/Floodjet Nozzles

\$449

LAWN & GARDEN BATTERIES

9 Plate
225 Amps
Reg. \$29.99

AS LOW AS
\$21.95

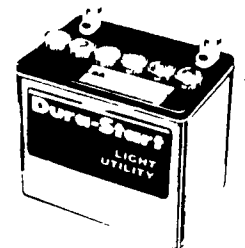

JOHANNING'S

Family Store

2460 New Holland Pike, Lancaster, PA 17601
¼ Mile West of Meadowbrook Farmers Market,
Rt. 23, Leola

(717) 656-3700 or (717) 291-4420

HOURS: Mon.-Thurs. 8 AM - 8 PM
Fri. 8 AM - 9 PM; Sat. 8 AM - 5 PM

If an advertised item is not available for purchase due to any unforeseen reason, Johanning's will issue a rain check for the merchandise to be purchased at the sale price whenever available. We reserve the right to correct printing errors and to limit quantities.

