

## Area Northrup King Managers Attend Sales Conference

MINNEAPOLIS, MN — A.G. Laos, Agri-Products Division vice-president of Northrup King Co., recently assured sales managers that despite the drought, the New Northrup King would provide an adequate supply of high-quality seed to farmers at a fair price and continue its strong investment in research. Northrup King Co. is the second-largest commercial seed company in America.

Attending the company's national sales meeting was Jack Gaudette, regional sales manager from Doylestown, Pa.; Steve Shipman, district sales manager from Mill Hall, Pa.; and Bill Snyder, district sales manager from Chestertown, Md. The meeting was held at the Sheraton Park Place Hotel in Minneapolis, Minn., on July 17 to 21. The company presented the year's new sales and marketing programs to its Agri-

Products employees. Attendees also discussed farmers' service needs and toured the company's seed research and biotechnology center in Stanton, Minn.

In his opening address, Laos said, "Not many seed companies have the skills or backing to even attempt to meet the challenges of the drought. Fortunately, we have the experience and resources to offer solutions."

He continued, "The New North-

rup King has an excellent inventory of high-quality seed. We also have the resources and facilities to produce a top-quality seed crop almost anywhere in the world. We will have major production of key hybrids in South America and Texas, this winter. And, our expert agronomic staff will help farmers manage their crops to minimize the long-term effects of the drought."

The seed industry has become more competitive in recent years,

added Don Jacoby, vice president of sales. Rapid technological change has meant shorter product life cycles. "Customer needs must dominate our thinking. We are competing for farmers' business on quality and service," said Jacoby. "The drought and its effects will be a real test of our ability to deliver our best. The American farmer is going to look for help, for solutions, for leadership."

# A DEPENDABLE BALER AT AN AFFORDABLE PRICE!

## 551 Rectangular Baler

If you're looking for a baler loaded with value, see the new Model 551 Rectangular Baler from New Idea.

The 551 Rectangular Baler features:

- Deering type Knotter
- Dual Packer Finger Design
- Constant Velocity PTO
- 271 Sq. In. Feed Opening

For a dependable baler at an affordable price, take a look at the New Idea 551 Rectangular Baler today!

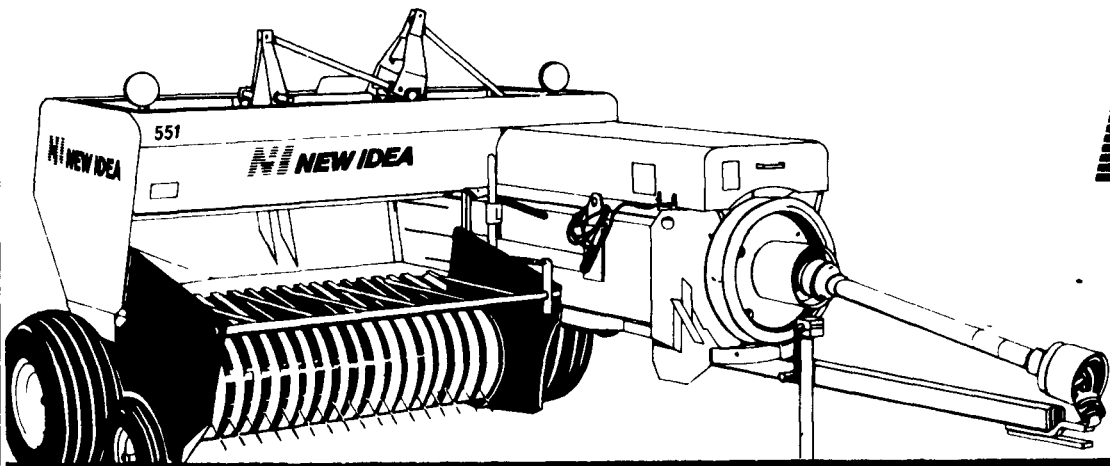

## SEE YOUR NEW IDEA DEALER TODAY

### PENNSYLVANIA

**Airville**  
FARMERS EQ. & SUPPLY CO., INC.  
717-862-3967 or 3968

**Bechtelsville**  
MILLER EQUIPMENT  
215-845-2911

**Bellefonte**  
IVAN J. ZOOK & SONS, INC.  
717-935-2948

**Bethel**  
ZIMMERMAN'S FARM SERVICE  
717-933-4114

**Cochranville**  
STOLTZFUS FARM SERVICE  
215-593-2407

**Cresson**  
HINES EQUIPMENT  
814-886-4183

**Bellwood**  
814-742-8171

**Dover**  
GEORGE N. GROSS, INC.  
717-292-1673

**Easton**  
FANCY FURROW FARMS AG. EQ.  
215-252-8828

**Ephrata**  
ROY H. BUCH, INC.  
RD 2  
717-859-2441

**Everett**  
SOLLENBERGER EQUIPMENT,  
INC.  
814-652-5223

**Gettysburg**  
YINGLING'S IMPLEMENTS  
717-359-4848

**Greencastle**  
MEYERS IMPLEMENTS, INC.  
717-597-2176

**Hamburg**  
SHARTLESVILLE  
FARM SERVICE  
RD 1  
215-488-1025  
H. Daniel Wenger, Prop.

**Honesdale**  
MARSHALL MACHINERY, INC.  
717-729-7117

**Jersey Shore**  
THOMAS L. DUNLAP  
717-398-1391

**Jerseytown**  
WILLIAM F. WELLIVER  
717-437-2430

**Jonestown**  
HEISEY FARM EQUIP., INC.  
RD 1  
717-865-4526

**Kittanning**  
W.C. CRYTZER EQUIP., INC.  
412-543-2441

**Klingerstown**  
STANLEY'S FARM SERVICE  
717-648-2088

**Lebanon (Fontana)**  
UMBERGER'S OF FONTANA  
RD 4  
717-867-5161

**Maxatawny**  
N.H. FLICKER & SONS, INC.  
215-683-7252

**Mifflinburg**  
BS & B REPAIR  
717-966-3756

**Mill Hall**  
DUNKLE AND GRIEB  
717-726-3115

**New Holland**  
A.B.C. GROFF, INC.  
717-354-4191

**Oakland Mills**  
PEOPLES SALES & SERVICE, INC.  
717-463-2735

**Quakertown**  
C.J. WONSIDLER BROS.  
215-536-1935

**Quarryville**  
A.L. HERR & BRO.  
717-786-3521

**Spring Mills**  
RT. 45 SALES  
& SERVICE  
RD 1  
814-422-8805

**State College**  
R.T. MARKLE  
1841 Pine Hall Drive  
814-237-3141

**Tunkhannock**  
ACE-JURISTA, INC.  
717-836-2610

### MARYLAND

**Churchville**  
WALTER G. COALE, INC.  
301-734-7722  
301-879-1434

**Frederick**  
KNOTT & GEISBERT, INC.  
RD 2  
301-662-3800

**Hagerstown**  
ANTIETAM FORD TRACTOR  
301-791-1200

**Lineboro**  
WERTZ GARAGE, INC.  
301-374-2672

**Rising Sun**  
BIGGS, INC.  
301-658-5531

### NEW JERSEY

**Bridgeton**  
LESLIE FOGG INC.  
609-935-5145

**Columbus**  
REED BROS. EQUIPMENT  
609-298-3441

### WEST VIRGINIA

**Martinsburg**  
BENDERS FARM SERVICE INC.  
304-267-8707