

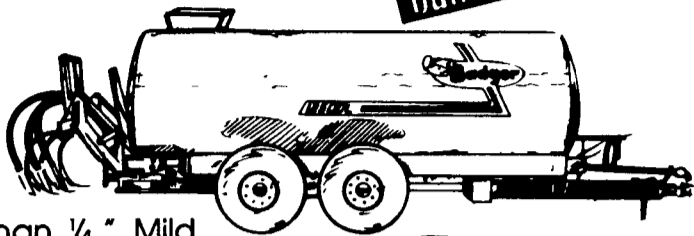

**LET YOUR BADGER DEALER
GET YOU READY FOR**



**Liquid Spreader Tanks
now built with
COR-TEN Steel**



Better Than 1/4" Mild Carbon Steel

- 20% stronger
- up to 8 times more corrosion resistant
- 10% lighter in weight
- retains its "new" look much longer
- 10-year limited warranty
- From 1500 to 3350 gallon capacity
- Three, four or five-shank injectors available
- 540 or 1000 RPM
- Direct drive heavy-duty PTO

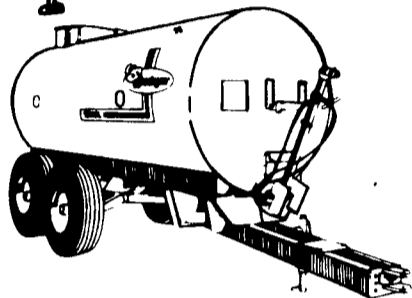
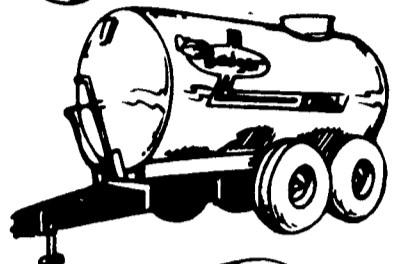

- Heavy T-frame draw bar
- Walking tandems standard

The best Forage Box you can buy is built by

Badger

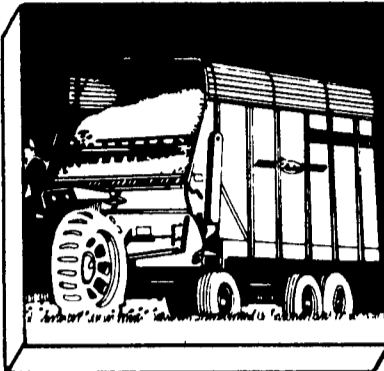

Now With **WAIVER OF FINANCE**
Until Sept. 1, 1988

OR

- LOW RATE FINANCING**
- 0 % For 12 Months
 - 5.9% For 24 Months
 - 8.9% For 36 Months

Badger SPREADERS
Built stronger to last longer!

Five Models Available - In Four Sizes
To Fit Your Needs

Now With **WAIVER OF FINANCE**
Until Oct. 1, 1988

- OR **LOW RATE FINANCING**
- 0 % For 12 Months
 - 5.9% For 24 Months
 - 8.9% For 36 Months

Badger



**High Capacity
MANURE AUGER**

For handling wet, sloppy manure.

- 15" diameter heavy wall PVC pipe won't rust or corrode
- Heavy-duty drive frame with double reduction drive for extra strength
- High capacity 13 1/4" auger
- Designed for minimum maintenance, long service-free life

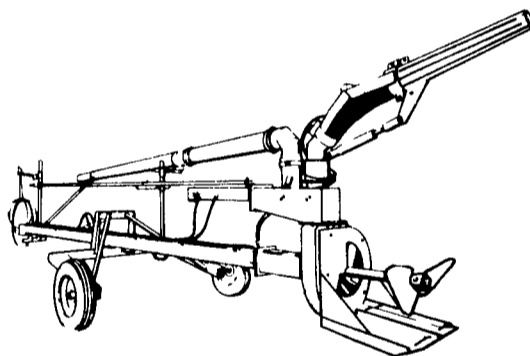

NEW
**Badger BN185
Souper Trail Pump/Agitator**

- Up to 26,000 GPM agitation capacity
- Standard 28 foot length extendable to 38 feet for really big lagoons
- Choice of cutter blade or propeller options to match biggest agitation needs
- Exclusive internal shear bar chops even straw-laden manure
- Semi-cupped impeller paddles for high capacity pumping

Badger

**BN103
Does it
all
for less!**

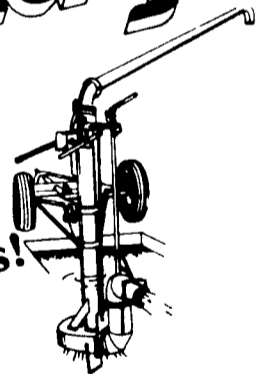

- Versatile — agitates, pumps, fills
- Fills 3000 gallon tank in one minute
- Performance options to meet your needs
- Ideal for dairy, hog or beef operations
- Built to last!

CALL YOUR LOCAL DEALER FOR ALL YOUR EQUIPMENT NEEDS

**WE OFFER A FULL LINE
OF EQUIPMENT WITH
FINANCING OR LEASING**

- | | | | | | |
|---|---|---|---|---|--|
| *BHM FARM EQUIP. INC.
RR 1
Annville, PA 17003
PH (717) 867-2211 | PIKEVILLE EQUIPMENT INC.
RT 2
Oley, PA 19547
PH (215) 987-6277 | WILLIAMS FARM SYSTEMS
RR 1, Box 324
Linden, PA 17744
PH (717) 398-0829 | C. PAUL FORD & SON
RT 1
Everett, PA 15537
PH (814) 652-2051 | MELVIN G. MILLER
RT 2
Spring Mills, PA 16875
PH (814) 422-8279 | HEFLIN SALES & SERVICE
12312 Oak Hill Rd
Woodsboro, MD 21798
PH (301) 898-3233 |
| *CHIDESTER FARMS
RD 2, Box 75
Kingsley, PA 18826
PH (717) 289-4260 | McMILLEN BROS.
RR 1
Loysville, PA 17047
PH (717) 789-3961 | ROY MOTORS CO.
Troy, PA 16947
PH (717) 297-3674 | SOMERSET BARN
EQUIPMENT
RD 5, Box 98
Somerset, PA 15501
PH (814) 445-5555 | LEONARD WORK
RR 3
Brookville, PA 15825
PH (814) 849-3361 | FANCY FURROW FARMS
AG EQUIP., INC.
RR 1, Uhler Rd
Easton, PA 18042
PH (215) 252-8828 |
| SHOW EASE STALL CO.
573 Willow Rd
Lancaster, PA 17601
PH (717) 299-2536 | HONESDALE SPREADING
SERVICE INC.
505 Cliff St
Honesdale, PA 18431
PH (717) 253-2410 | HESS' EQUIPMENT
Sales & Service
RR 3, Mifflinburg, PA 17844
PH (717) 966-2720
966-1998 | WOLFE'S BADGER SALES
RR 1 Box 420
Milton, PA 17847
PH (717) 524-0931 | CECIL DAIRY STORE
RR 1 Rt. 274
1/2 Mi. South Rising Sun, MD
21911
PH. (301) 658-6923 | |

*NEW DEALERS