



Marlin Hoff Best 3 Females

Peace & Plenty Best 3 Females

Junior

(Continued from Page E2)

Reserve
Rinehart Dazzler Floren, Jenelle Rinehart
Summer Yearling
Peace & Plenty Div Mayfield, Shane Schwartzbeck

Reserve
Heff-Haven Pete Milly, Gaylene Smith

Junior Yearling
Peace & Plenty SWD Justina-ET

Reserve
Coldsprings Natural Raffia, Matthew M. Hoff

Intermediate Yearling
DCS-Dairy Sammy Ball, Crystal

A. Smith
Reserve
Char-D Gold Deanne, Nancy Powel

Senior Yearling
Cowlick Saul Carla, Wyatt Griffin

Reserve
High Honorable Mention All-American
Hills-Hope Val Cindy Sue-ET,
(Turn to Page E4)

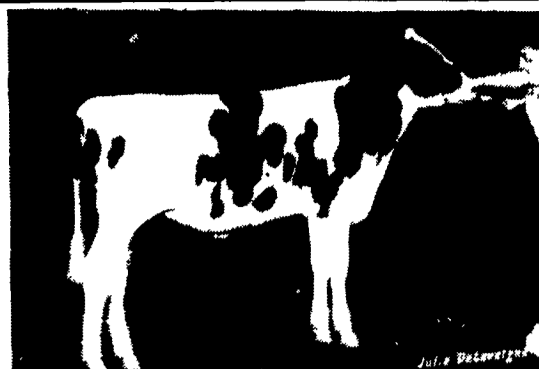

Ehrhardt Tempo Katie



Gay-Ridge Starbuck Sue



Peace & Plenty Div Mayfield



Peace & Plenty SWD Justina-ET



DCS-Dairy Sammy Ball



Cowlick Saul Carla



Ehrhardt Clipper Josephine

SPRING CLEAN-UP SPECIAL

on all 1988

SAVE 20% Karcher Pressure Washers

Karcher's New Cold-Hot-Steam Pressure Cleaners: 4x High-Pressure in Perfection

Single Phase

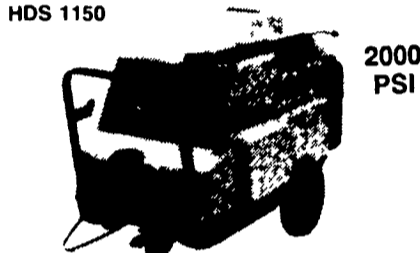
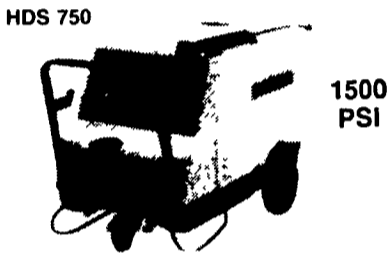
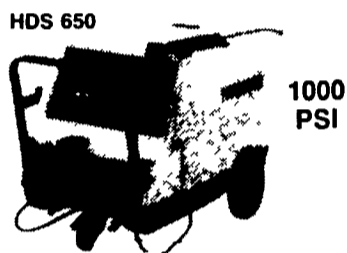

Three Phase

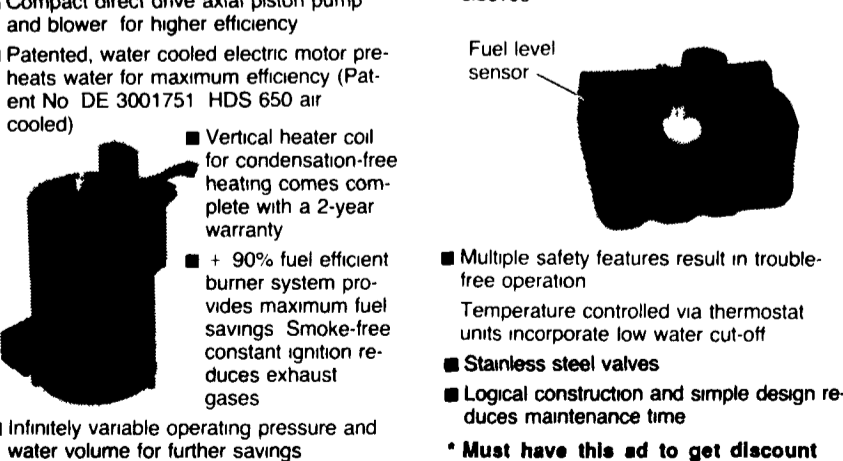
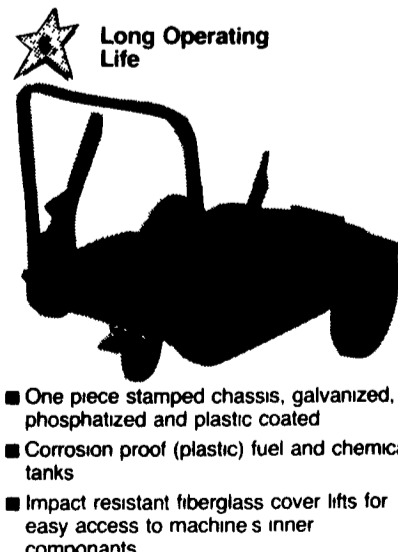
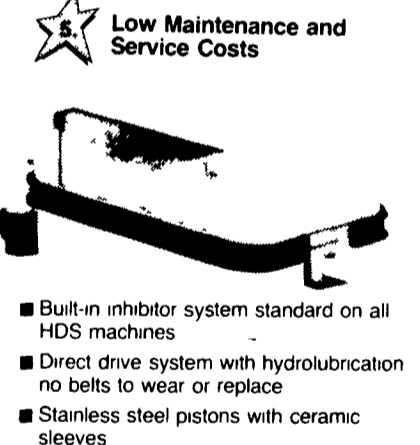
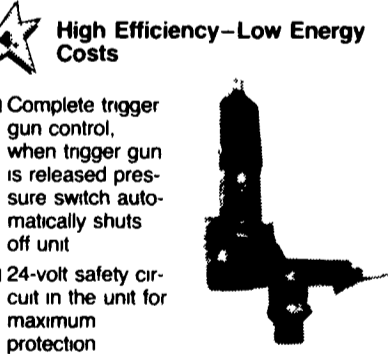
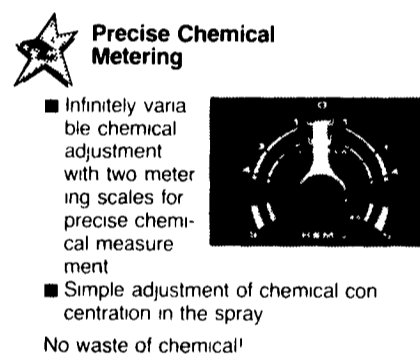
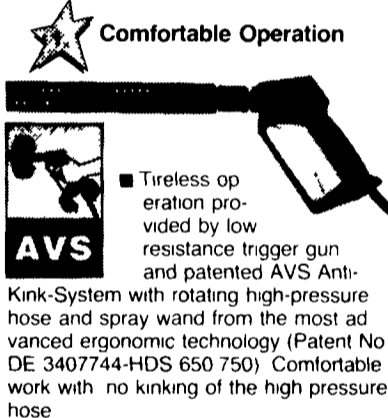
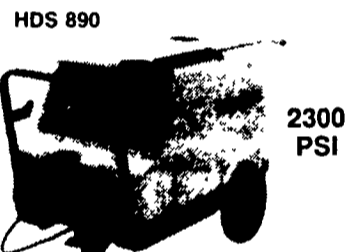

DEALER INQUIRIES INVITED

KOCHEL EQUIPMENT CO.

Distributor for S.E. & S.C. PA
RT. 23, ELVERSON, PENNSYLVANIA
PA (800) 922-9680
(215) 286-5519