

**RUBBER MATTING AND USED BELTING**

- COMFORT STALLS
- FREE STALLS
- HORSE STALLS
- CATTLE & HORSE TRAILERS
- HOG PENS & HOUSES

All Sizes Available & Custom Cut  
Phone 301-885-5045

**FIND OUT!**  
Why the most progressive dairymen in the northeast are using the **HEMOCEL 100** Program for herd health and production.  
For your nearest dealer contact

**agri-dynamics**  
P.O. Box 318, Martins Creek, PA 18063  
(215) 588-8150

**High Performance . . . A HiPerForm Standard Feature!**



**MUELLER HiPerForm**

No other cooler offers so many high performance features.

- 1000 Gal. Mueller
- 600 Gal. "OH"

**OTHER USED TANKS AVAILABLE**

Used 3, 4 & 5 HP Condensing Units R12 & R22

Trust! We Work At It.

**AUTH. MUELLER DEALER**  
**GEORGE M. PRIEST, & SONS**  
RD 8, Box 142 Hagerstown, MD 21740  
301-797-3921  
24 HOUR SERVICE

**ATTENTION BUY OUT FARMERS**

We Need Good Used Tanks  
500 - 6000 Gal. - Call Us

**USED BULK TANKS**

All Tanks Guaranteed A-1 Working Condition

- 600 & 700 Gal. Mueller "M's"
- 400 Gal. Sunset
- 400 Gal. Girton
- 500 Gal. Milkeeper
- 500 Gal. Girton D-4
- 500 Gal. Girton
- 600 Gal. Jamesway
- 600 Gal. Jamesway
- (2) 600 Gal. Milkeepers (Round)
- 600 Gal. Girton
- 600 Gal. Steinhurst
- 625 Gal. Sunset
- 735 Gal. Sunset
- 800 Gal. Girton D4
- 800 Gal. Mojonner
- 800 Gal. Van Veeter
- 800 Gal. Zero
- 800 Gal. "OH"
- 800 Gal. Darl Kool
- 1000 (SOLD) Darl-Kool
- 1000 Gal. Sunset
- 1000 Gal. DeLaval
- 1000 Gal. Milkeeper
- 1200 Zero (No Leaker)
- 1200 Gal. Sunset
- 1500 (SOLD) Jeller
- 1500 Gal. Mueller
- 2000 Gal. Mueller
- 2500 Gal. DeLaval
- 4000 Gal. Girton
- 600 GAL 31" POURING HEIGHT VERY NICE
- 400, 500, 600 & 800 Gal. (Storage Tanks)
- 1 - Good Used Heat Exchanger
- Used 3 & 5 H.P. Electric Motors

**USED COMPRESSORS**

3 H.P., 4 H.P., 5 H.P. — R12 & R22

24 Hrs. - 7 Days A Week - Refrigeration Service  
Installation, Sales And Service

**RAY SHENK**

505 E. Woods Drive Lititz, PA 17543  
Sales 717-626-1151  
24 Hr. Service 717-627-2747

**Cut 50% of the agitation time. Get a dual agitation pump that matches the power of your tractor.**

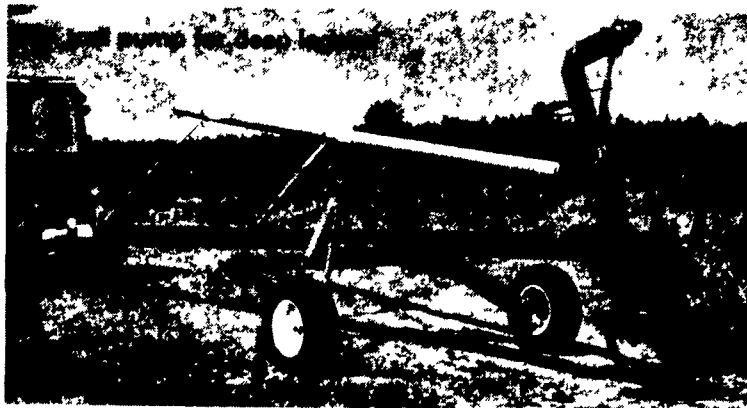

- Fastest agitation of heavily crusted manure storage pits by the nozzle located over the settled manure.
- Constant homogenization of bottom sediment by the propeller displacing up to 18000 G.P.M.
- Hydraulic controls operated from tractor seat

Our pumps are available with different gear box ratios to suit any tractor from 60 to 120 H.P.

- 3-point hitch model for shallow lagoon also available.

**US AGRI-SYSTEMS**

SPECIALIZED FARM EQUIPMENT

OXFORD, PA 19363

(800) 222-2948

(301) 398-2948

MANURE MANAGEMENT SPECIALISTS

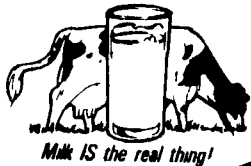

A 1st Class Team Together For 20 Years!



**RUFUS BRUBAKER REFRIGERATION & MUELLER Dairy Farm Equipment**

**OFFER**

**TWO WAYS TO "PRECOOL" MILK**

One With Water

**MUELLER ACCU-THERM™ PRECOOLER**

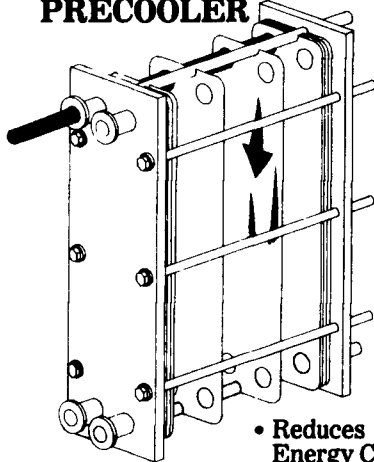

• Reduces Energy Cost

- Flexibility
- Low Maintenance
- Pays For Itself

**MUELLER Accu-Therm PLATE HEAT EXCHANGER**

One With Freon

**MUELLER REFRIGERATED RECEIVER**



**PRE-COOLING DOES MAKE A DIFFERENCE!**

Isn't it time for you to join the growing number of dairymen testifying to the improvement the Refrigerated Receiver has made in their operations!

**take a closer look!**

**MUELLER HiPerForm**



- HiPerForm Refrigeration Control
- Mueller Matic Washing System
- Flashing Alarm Light When Milk Is Too Warm or Too Cold
- There's Just No Substitute for a HiPerForm Milk Tank!

**USED TANKS**

Large Selection Of Good Used Tanks In Stock All Guaranteed

**MARTIN'S REFRIGERATION, INC.**

Phone (717) 352-2783 Sales & Service

1122 Woodstock Rd Fayetteville, Pa 17222

**Southern Service Center**  
468 Dry Wells Rd. Quarryville, Pa.  
717-786-1617  
Vic Leininger

**MAIN OFFICE**

614 Penryn Rd. Manheim, Pa. 17545  
717-665-3525  
Ken or Ed Brubaker

**Northern Service Center**  
RD 1, Box 199 Myerstown, Pa.  
717-933-4711  
Ken Kopp

★ 24 Hour Service In S.E. PA, S. Jersey, Delaware N.E. And Eastern Shore Maryland!

★ Call Today For All Your New or Used Milk Tank And Refrigeration Equipment Needs!