

6 DAIRY EQUIPMENT

Complete Universal 2" SS pipeline system for 88 cows w/7½ HP pump, 8 full view units, washer, like new condition, \$9,000; two Berg Choremaster barn cleaners w/282' chain each, new in fall of 1984, \$3,250 ea; one Badger power track unloader for 16' diameter silo, \$1,000; Van Dale magnematic 360 silo unloader for 22' diameter silo, one yr. old \$3,000.

717-587-1725
Lackawana Co., PA

FOR SALE Dairy Equipment From Buy-Out Farm

1. 1000 gal. tank & washer, needs compressor \$2500
2. Surge Alamo #1200 vacuum pump. 1 year old \$1500
3. Surge electric pulsation for parlor - 4 units & milkers \$500
4. Mueller Free Heater \$750
5. Computer Feeder, will feed 2 feeds incl. HM corn to 80± cows \$6000

717-659-5245

Weekdays 8 to 5; Sat. 8 to 3
Ask For "JAKE" ENSMINGER

ROSKAMP STATIONARY CORN SILAGE ROLLER MILL

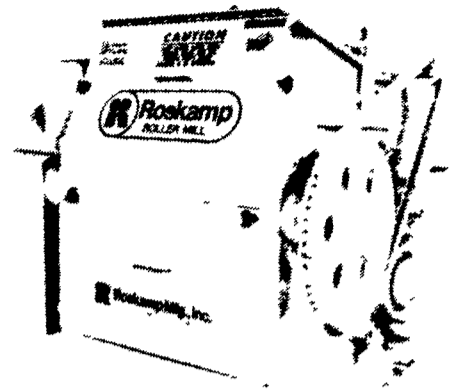

FOR DAIRY
Rolling silage fresh - just before feeding - increases milk production.

FOR BEEF
Less silage is required per pound of gain when silage is freshly rolled before feeding.

FOR HOGS
Freshly rolled silage, with all kernels cracked and all cobs crushed provides a highly palatable and more readily assimilated feed for sows.

DUAL PURPOSE
Hi-moisture or dry shelled corn can be metered into the Roskamp Silage Mill Hopper along with the silage for a uniformly mixed and digestible ration.

University tests have proven that 20% of high moisture whole corn passes through the animal's system undigested. This means every fifth scoopful of expensive grain is left on your feedlot!

That's why it's money in the bank to freshly roll every bit of high moisture or dry corn just before feeding. Freshly rolled feed is the most palatable and digestible.

DONALD R. NISSLEY
RD #1, Willow Street, PA
(Corner of Rt. 272 S. & Byerland Church Rd.)
(717) 786-7654

Full Line
Parts Department
For Starline

STOP
Don't Replace or Install Animal Drinkers before you investigate

Energy Free DRINKERS

For Cattle Hogs, Calves Sheep, Horses



Highcroft's fiberglass drinkers are specially insulated - require no electricity or heat to prevent freezing. Hold ground water temperature - summer and winter. Rugged uncomplicated design for long service. Easily connected to present water line.

NOW...Six Models

We are probably the most experienced Energy Free drinker dealers in the East with over 7 years experience. Write or call for more information.

Knutsen Bros.

130 Knutsen Lane
Rising Sun, MD 21911

301-658-6325 or 658-4283

LANCASTER DAIRY FARM AUTOMATION

DARI-KOOL SYSTEMS

A new, more efficient FULL-FLOW Refrigeration System



DARI-KOOL Coolers

- Heavy-Duty Agitators
- Efficient Polyurethane Insulation
- Internal Structural Steel Support Frames
- Completely Stainless Steel Exterior
- Sizes From 450 to 6000 Gallons
- Ladder Equipped On 1250 Sizes And Larger
- High Efficiency Twin-Evaporator Plate Design
- All New FULL-FLOW Refrigeration System - Reduces head pressure and allows cooler, more efficient compressor operation

RD 5, Box 184, East End Drive
Manheim, PA 17545
(717) 665-7300



A 1st Class Team
Together For 20 Years!



RUFUS BRUBAKER REFRIGERATION & MUELLER Dairy Farm Equipment

OFFER

TWO WAYS TO "PRECOOL" MILK

One With Water

MUELLER ACCU-THERM™ PRECOOLER

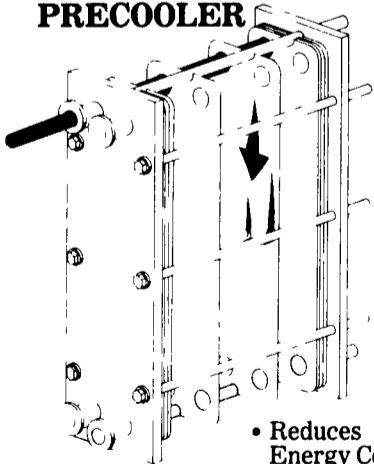

• Reduces Energy Cost

- Flexibility
- Low Maintenance
- Pays For Itself

MUELLER Accu-Therm PLATE HEAT EXCHANGER

One With Freon

MUELLER REFRIGERATED RECEIVER



PRE-COOLING DOES MAKE A DIFFERENCE!

Isn't it time for you to join the growing number of dairymen testifying to the improvement the Refrigerated Receiver has made in their operations!

Southern Service Center
468 Dry Wells Rd.
Quarryville, Pa.
717-786-1617
Vic Leininger

MAIN OFFICE
614 Penryn Rd.
Manheim, Pa. 17545
717-665-3525
Ken or Ed Brubaker

Northern Service Center
RD 1, Box 199
Myerstown, Pa.
717-933-4711
Ken Kopp

* 24 Hour Service In S.E. PA, S. Jersey, Delaware N.E. And Eastern Shore Maryland!

* Call Today For All Your New or Used Milk Tank And Refrigeration Equipment Needs!

HOWLE
WE DELIVER ANYWHERE

YOUR HEADQUARTERS FOR NEW AND USED LIQUID MANURE EQUIPMENT

US AGRI-SYSTEMS
SPECIALIZED FARM EQUIPMENT

OXFORD, PA 19363

(800) 222-2948

(301) 398-2948